



7750 SR OS Routing Protocols Guide

Software Version: 7750 SR OS 10.0.R1
February 2012
Document Part Number: 93-0074-09-01



This document is protected by copyright. Except as specifically permitted herein, no portion of the provided information can be reproduced in any form, or by any means, without prior written permission from Alcatel-Lucent.
Alcatel, Lucent, Alcatel-Lucent and the Alcatel-Lucent logo are trademarks of Alcatel-Lucent. All other trademarks are the property of their respective owners.
The information presented is subject to change without notice.
Alcatel-Lucent assumes no responsibility for inaccuracies contained herein.

Copyright 2012 Alcatel-Lucent. All rights reserved.

Table of Contents

Preface	15
Getting Started	
Alcatel-Lucent 7750 SR-Series Router Configuration Process	19
Multicast	
Introduction to Multicast	22
Multicast Models	23
Any-Source Multicast (ASM)	23
Source Specific Multicast (SSM)	23
IPv6 Multicast	25
Multicast Listener Discovery (MLD v1 and v2)	25
PIM SSM	25
IPv6 PIM ASM	26
Embedded RP	26
Core Router Multicast Requirements	27
Internet Group Management Protocol	27
IGMP Versions and Interoperability Requirements	28
IGMP Version Transition	28
Source-Specific Multicast Groups	29
Protocol Independent Multicast Sparse Mode (PIM-SM)	30
PIM-SM Functions	30
Encapsulating Data Packets in the Register Tunnel	33
PIM Bootstrap Router Mechanism	33
PIM-SM Routing Policies	33
Reverse Path Forwarding Checks	35
Anycast RP for PIM-SM	36
Auto-RP (discovery mode only) in Multicast VPN	39
Multicast Extensions to MBGP	40
MBGP Multicast Topology Support	40
Multicast Source Discovery Protocol (MSDP)	41
Anycast RP for MSDP	41
MSDP Procedure	42
MSDP Peer Groups	43
MSDP Mesh Groups	43
MSDP Routing Policies	44
Multicast in Virtual Private Networks	45
Multicast Debugging Tools	46
Mtrace	46
Mstat	48
Mrinfo	48
Multicast Connection Admission Control (MCAC)	49
BTV	49
Interface-Level CAC	53
Bundle-Level CAC	53

Table of Contents

Dealing with Configuration Changes	53
Distributing PIM Joins over Multiple ECMP Paths	55
LAG Interworking	59
CAC Policy for Split Horizon Groups	60
Dynamic Multicast Signaling over P2MP LDP	61
Multicast Configuration Process Overview	62
Configuration Notes	63
General	63
Configuring Multicast Parameters with CLI	65
Multicast Configuration Overview	66
Basic Configuration	67
Common Configuration Tasks	70
Configuring IGMP Parameters	70
Enabling IGMP	70
Configuring an IGMP Interface	71
Configuring Static Parameters	72
Configuring SSM Translation	74
Configuring PIM Parameters	75
Enabling PIM	75
Configuring PIM Interface Parameters	76
Importing PIM Join/Register Policies	81
Configuring Multicast Source Discovery Protocol (MSDP) Parameters	83
Configuring MCAC Parameters	84
Service Management Tasks	87
Disabling IGMP or PIM	87
Multicast Command Reference	91
Configuration Commands	105
Generic Commands	105
Router IGMP Commands	108
Router PIM Commands	117
Multicast CAC Policy Configuration Commands	144
MLD Commands	151
Operational Commands	157
Show Commands	163
IGMP Commands	163
Show Router PIM Commands	176
Clear Commands	216
Debug Commands	224
Debug IGMP Commands	224
Debug PIM Commands	227

RIP

RIP Overview	234
RIP Features	235
RIP Version Types	235
RIPv2 Authentication	235
Metrics	236
Timers	236
Import and Export Policies	236

RIP Packet Format	237
Hierarchical Levels	239
RIP Configuration Process Overview	240
Configuration Notes	241
General	241
Configuring RIP with CLI	243
RIP Configuration Overview	244
Preconfiguration Requirements	244
RIP Hierarchy	244
Basic RIP Configuration	245
Common Configuration Tasks	246
Configuring Interfaces	247
Configuring a Route Policy	248
Configuring RIP Parameters	250
Configuring Global-Level Parameters	252
Configuring Group-Level Parameters	253
Configuring Neighbor-Level Parameters	254
RIP Configuration Management Tasks	255
Modifying RIP Parameters	255
Deleting a Group	256
Deleting a Neighbor	256
RIP Command Reference	257
RIP Configuration Commands	261
Generic Commands	261
Show Commands	273
Clear Commands	284
Debug RIP Commands	285
OSPF	
Configuring OSPF	288
OSPF Areas	289
Backbone Area	289
Stub Area	290
Not-So-Stubby Area	291
OSPFv3 Authentication	297
OSPFv3 Graceful Restart Helper	298
Virtual Links	300
Neighbors and Adjacencies	301
Link-State Advertisements	302
Metrics	302
Authentication	303
IP Subnets	304
Preconfiguration Recommendations	304
Multiple OSPF Instances	305
Route Export Policies for OSPF	305
Preventing Route Redistribution Loops	306
IP Fast-reroute (IP FRR) For OSPF and IS-IS Prefixes	307
IP FRR Configuration	307
ECMP Considerations	308

Table of Contents

IP FRR and RSVP Shortcut (IGP Shortcut)	308
OSPF and IS-IS Support for Loop-Free Alternate Calculation	309
OSPF Configuration Process Overview	313
Configuration Notes	314
General	314
OSPF Defaults	314
Configuring OSPF with CLI	315
OSPF Configuration Guidelines	316
Basic OSPF Configuration	317
Configuring the Router ID	318
Configuring OSPF Components	319
Configuring OSPF Parameters	319
Configuring OSPF3 Parameters	320
Configuring an OSPF or OSPF3 Area	321
Configuring a Stub Area	322
Configuring a Not-So-Stubby Area	324
Configuring a Virtual Link	326
Configuring an Interface	328
Configuring Authentication	331
Assigning a Designated Router	334
Configuring Route Summaries	336
Configuring Route Preferences	338
OSPF Configuration Management Tasks	341
Modifying a Router ID	341
Deleting a Router ID	343
Modifying OSPF Parameters	344
OSPF Command Reference	347
Configuration Commands	353
Generic Commands	353
OSPF Global Commands	354
OSPF Area Commands	371
Interface/Virtual Link Commands	377
Show Commands	389
Clear Commands	433
OSPF Debug Commands	435

IS-IS

Configuring IS-IS	442
Routing	443
IS-IS Frequently Used Terms	445
ISO Network Addressing	446
IS-IS PDU Configuration	448
IS-IS Operations	448
IS-IS Route Summarization	449
IS-IS Multi-Topology for IPv6	450
IS-IS Administrative Tags	451
Setting Route Tags	451
Using Route Tags	452
IP Fast-reroute (IP FRR) For IS-IS Prefixes	453

IP FRR Configuration	453
ECMP Considerations	454
IP FRR and RSVP Shortcut (IGP Shortcut)	454
OSPF and IS-IS Support for Loop-Free Alternate Calculation	455
IS-IS Configuration Process Overview	459
Configuration Notes	460
General	460
Configuring IS-IS with CLI	461
IS-IS Configuration Overview	462
Router Levels	462
Area Address Attributes	462
Interface Level Capability	463
Route Leaking	464
Basic IS-IS Configuration	465
Common Configuration Tasks	467
Configuring IS-IS Components	468
Enabling IS-IS	468
Modifying Router-Level Parameters	468
Configuring ISO Area Addresses	470
Configuring Global IS-IS Parameters	471
Migration to IS-IS Multi-Topology	472
Configuring Interface Parameters	476
IS-IS Configuration Management Tasks	481
Disabling IS-IS	481
Removing IS-IS	481
Modifying Global IS-IS Parameters	482
Modifying IS-IS Interface Parameters	483
Configuring Leaking	485
Redistributing External IS-IS Routers	488
Specifying MAC Addresses for All IS-IS Routers	489
IS-IS Configuration Commands	491
Generic Commands	491
IS-IS Command Reference	521
Show Commands	527
Clear Commands	559
Debug Commands	561
BGP	
BGP Overview	566
BGP Communication	566
Message Types	566
Group Configuration and Peers	568
Hierarchical Levels	569
Route Reflection	569
Fast External Failover	572
Sending of BGP Communities	572
BGP Route Tunnel	573
ECMP and BGP Route Tunnels	573
Layer 2 Services and BGP Route Tunnel	573

Table of Contents

BGP Route Tunnel SDP Binding	573
BGP Route Tunnel Based BGP-AD Support	574
BGP Route Tunnel with multi-hop eBGP session	574
RSVP-TE LSP Shortcut for BGP Next-Hop Resolution	575
Core IPv4 Prefix Resolution	575
Handling of Control Packets	576
BGP Confederations	577
BGP Decision Process	579
Option to Ignore Router ID	579
always-compare-med Command	580
Option to Ignore Next-Hop Metric	581
Best External	583
Advertisement Rules with Best External	583
BGP Add-Path	584
Sending Multiple Paths per Prefix to Add-Paths Peers	586
BGP Fast Reroute	587
Command Interactions and Dependencies	593
Changing the Autonomous System Number	593
Changing the Local AS Number	594
Changing a Confederation Number	594
Changing the Router ID at the Configuration Level	594
Hold Time and Keep Alive Timer Dependencies	595
Import and Export Route Policies	596
Route Damping and Route Policies	596
AS Override	596
BGP FlowSpec	597
Validating and Importing Received IPv6 Flow Routes into the Routing Table	598
Propagating IPv4 Flow Routes to BGP Neighbors	599
Using IPv4 Flow Routes to Create Dynamic IPv4 Filter Entries	599
TTL Security for BGP and LDP	601
BGP Configuration Process Overview	602
Configuration Notes	603
General	603
BGP Defaults	603
BGP MIB Notes	604
Configuring BGP with CLI	607
BGP Configuration Overview	608
Preconfiguration Requirements	608
BGP Hierarchy	608
Internal and External BGP Configurations	608
Basic BGP Configuration	610
Common Configuration Tasks	612
Creating an Autonomous System	613
Configuring a Router ID	614
BGP Confederations	615
BGP Route Reflectors	617
BGP Components	619
Configuring Group Attributes	620
Configuring Neighbor Attributes	621

Configuring Route Reflection	622
Configuring a Confederation	623
BGP Configuration Management Tasks	624
Modifying an AS Number	624
Modifying a Confederation Number	625
Modifying the BGP Router ID	625
Modifying the Router-Level Router ID	626
Deleting a Neighbor	627
Deleting Groups	628
BGP Command Reference	629
Configuration Commands	639
Other BGP-Related Commands	676
Show Commands	681
Clear Commands	721
Debug Commands	724
Route Policies	
Configuring Route Policies	732
Policy Statements	733
Default Action Behavior	734
Denied IP Prefixes	734
Controlling Route Flapping	735
Regular Expressions	737
BGP and OSPF Route Policy Support	742
BGP Route Policies	742
Re-advertised Route Policies	744
Triggered Policies	744
Set MED to IGP Cost using Route Policies	744
When to Use Route Policies	746
Route Policy Configuration Process Overview	747
Configuration Notes	748
General	748
Configuring Route Policies with CLI	749
Route Policy Configuration Overview	750
When to Create Routing Policies	750
Default Route Policy Actions	751
Policy Evaluation	752
Damping	755
Basic Configurations	756
Configuring Route Policy Components	758
Beginning the Policy Statement	759
Creating a Route Policy	760
Configuring a Default Action	761
Configuring an Entry	762
Configuring a Community List	763
Configuring Damping	764
Configuring a Prefix List	765
Configuring PIM Join/Register Policies	766
Configuring Bootstrap Message Import and Export Policies	768

Table of Contents

Route Policy Configuration Management Tasks	769
Editing Policy Statements and Parameters	769
Deleting an Entry	771
Deleting a Policy Statement	771
Route Policy Command Reference	773
Route Policy Command Reference	777
Generic Commands	777
Route Policy Options	779
Route Policy Damping Commands	782
Route Policy Prefix Commands	785
Route Policy Entry Match Commands	787
Route Policy Action Commands	797
Show Commands	805
Standards and Protocol Support	809
Index	815

List of Tables

Getting Started

Table 1:	Configuration Process	19
----------	---------------------------------	----

Multicast

Table 2:	Join Filter Policy Match Conditions	34
Table 3:	Register Filter Policy Match Conditions	34
Table 4:	Bundle definition and Channel Characterization	51
Table 5:	CAC Constraints	51
Table 6:	LAG/CAC Constraints	59

RIP

Table 7:	Route Preference Defaults by Route Type	269
Table 8:	RIP Neighbor Standard Output Fields	276

OSPF

Table 9:	Route Preference Defaults by Route Type	338
Table 10:	Route Preference Defaults by Route Type	359
Table 11:	Route Preference Defaults by Route Type	364

IS-IS

Table 12:	Potential Adjacency Capabilities	463
Table 13:	Potential Adjacency Capabilities	506

BGP

Table 14:	MED Comparison with always-compare-med	580
Table 15:	BGP Fast Reroute Scenarios	587
Table 16:	Subcomponents of IPv4 Flow Route NLRI	597
Table 17:	IPv4 Flowspec Actions	598
Table 18:	TiMOS and IETF MIB Variations	604
Table 19:	MIB Variable with SNMP	604

Route Policies

Table 20:	Regular Expression Operators	738
Table 21:	AS Path and Community Regular Expression Examples	739
Table 22:	Metric Set IGP Effect	745
Table 23:	Default Route Policy Actions	751

List of Tables

LIST OF FIGURES

Multicast

Figure 1:	Anycast RP for PIM-SM Implementation Example	37
Figure 2:	IP Router Configuration Flow	62

RIP

Figure 3:	RIP Packet Format	237
Figure 4:	RIPv1 Format	238
Figure 5:	RIPv2 Format	238
Figure 6:	RIP Configuration and Implementation Flow	240

OSPF

Figure 7:	Backbone Area	290
Figure 8:	PEs Connected to an MPLS-VPN Super Backbone	293
Figure 9:	Sham Links	294
Figure 10:	GRACE LSA Format	298
Figure 11:	Example Topology with Primary and LFA Routes	309
Figure 12:	Example Topology with Broadcast Interfaces	310
Figure 13:	OSPF Configuration and Implementation Flow	313
Figure 14:	OSPF Areas	387

IS-IS

Figure 15:	IS-IS Routing Domain	442
Figure 16:	Using Area Addresses to Form Adjacencies	447
Figure 17:	Example Topology with Primary and LFA Routes	455
Figure 18:	Example Topology with Broadcast Interfaces	456
Figure 19:	IS-IS Configuration and Implementation Flow	459
Figure 20:	Configuring a Level 1 Area	478
Figure 21:	Configuring a Level 1/2 Area	480

BGP

Figure 22:	BGP Configuration	568
Figure 23:	Fully Meshed BGP Configuration	570
Figure 24:	BGP Configuration with Route Reflectors	571
Figure 25:	BGP Update Message with Path Identifier for IPv4 NLRI	584
Figure 26:	BGP Fast Reroute for Remote PE Router Failure	591
Figure 27:	BGP Configuration and Implementation Flow	602
Figure 28:	Confederation Network Diagram Example	615
Figure 29:	Route Reflection Network Diagram Example	617

Route Policies

Figure 30:	BGP Route Policy Diagram	742
Figure 31:	BGP Route Policy Diagram	743
Figure 32:	OSPF Route Policy Diagram	743
Figure 33:	Route Policy Configuration and Implementation Flow	747
Figure 34:	Route Policy Process Example	753
Figure 35:	Next Policy Logic Example	754

List of Figures

Figure 36: Damping Example755

About This Guide

This guide describes routing protocols including multicast, RIP, OSPF, IS-IS, BGP, and route policies provided by the 7750 SR OS and presents configuration and implementation examples.

This document is organized into functional chapters and provides concepts and descriptions of the implementation flow, as well as Command Line Interface (CLI) syntax and command usage.

Audience

This manual is intended for network administrators who are responsible for configuring the 7750 SR-Series routers. It is assumed that the network administrators have an understanding of networking principles and configurations. Protocols, standards, and services described in this manual include the following:

- Multicast — IGMP and PIM-SM
- Routing Reservation Protocol (RIP)
- Open Shortest Path First (OSPF)
- Intermediate System to Intermediate System (IS-IS)
- Border Gateway Protocol (BGP)
- Route policies

List of Technical Publications

The 7750 SR documentation set is composed of the following books:

- **7750 SR OS Basic System Configuration Guide**
This guide describes basic system configurations and operations.
- **7750 SR OS System Management Guide**
This guide describes system security and access configurations as well as event logging and accounting logs.
- **7750 SR OS Interface Configuration Guide**
This guide describes card, Media Dependent Adapter (MDA), and port provisioning.
- **7750 SR OS Router Configuration Guide**
This guide describes logical IP routing interfaces and associated attributes such as an IP address, port, link aggregation group (LAG) as well as IP and MAC-based filtering, VRRP, and Cflowd.
- **7750 SR OS Routing Protocols Guide**
This guide provides an overview of routing concepts and provides configuration examples for RIP, OSPF, IS-IS, Multicast, BGP, and route policies.
- **7750 SR OS MPLS Guide**
This guide describes how to configure Multiprotocol Label Switching (MPLS) and Label Distribution Protocol (LDP).
- **7750 SR OS Services Guide**
This guide describes how to configure service parameters such as service distribution points (SDPs), customer information, and user services.
- **7750 SR OS OAM and Diagnostic Guide**
This guide describes how to configure features such as service mirroring and Operations, Administration and Management (OAM) tools.
- **7750 SR OS Triple Play Guide**
This guide describes Triple Play services and support provided by the 7750 SR 7450 ESS 7710 SR and presents examples to configure and implement various protocols and services.
- **7750 SR OS Quality of Service Guide**
This guide describes how to configure Quality of Service (QoS) policy management.
- **OS Multi-Service ISA Guide**
This guide describes services provided by integrated service adapters such as Application Assurance, IPSec, ad insertion (ADI) and Network Address Translation (NAT).

Technical Support

If you purchased a service agreement for your 7750 SR-Series router and related products from a distributor or authorized reseller, contact the technical support staff for that distributor or reseller for assistance. If you purchased an Alcatel-Lucent service agreement, contact your welcome center at:

Web: http://www1.alcatel-lucent.com/comps/pages/carrier_support.jhtml

Getting Started

In This Chapter

This chapter provides process flow information to configure IP routing protocols.

Alcatel-Lucent 7750 SR-Series Router Configuration Process

[Table 1](#) lists the tasks necessary to configure RIP, OSPF, and IS-IS, BGP, and multicast protocols, and route policies. This guide is presented in an overall logical configuration flow. Each section describes a software area and provides CLI syntax and command usage to configure parameters for a functional area.

Table 1: Configuration Process

Area	Task	Chapter
Protocol configuration	Configure routing protocols: <ul style="list-style-type: none">• Multicast• RIP• OSPF• IS-IS• BGP	Multicast on page 21 RIP on page 233 OSPF on page 287 IS-IS on page 441 BGP on page 565
Policy configuration	<ul style="list-style-type: none">• Configure route policies	Route Policies on page 731
Reference	List of IEEE, IETF, and other proprietary entities.	Standards and Protocol Support on page 809

In This Chapter

This chapter provides information about IPv6, Internet Group Management Protocol (IGMP) and Protocol Independent Multicast (PIM).

Topics in this chapter include:

- [Introduction to Multicast on page 22](#)
 - [Multicast Models on page 23](#)
- [IPv6 Multicast on page 25](#)
- [Core Router Multicast Requirements on page 27](#)
 - [Internet Group Management Protocol on page 27](#)
 - [Source-Specific Multicast Groups on page 29](#)
 - [Protocol Independent Multicast Sparse Mode \(PIM-SM\) on page 30](#)
 - [Anycast RP for PIM-SM on page 36](#)
 - [PIM SSM on page 25](#)
 - [Multicast Listener Discovery \(MLD v1 and v2\) on page 25](#)
 - [Multicast Extensions to MBGP on page 40](#)
 - [Multicast Source Discovery Protocol \(MSDP\) on page 41](#)
 - [Multicast Connection Admission Control \(MCAC\) on page 49](#)
 - [Distributing PIM Joins over Multiple ECMP Paths on page 55](#)
- [Multicast Configuration Process Overview on page 62](#)
- [Configuration Notes on page 63](#)

Introduction to Multicast

IP multicast provides an effective method of many-to-many communication. Delivering unicast datagrams is fairly simple. Normally, IP packets are sent from a single source to a single recipient. The source inserts the address of the target host in the IP header destination field of an IP datagram, intermediate routers (if present) simply forward the datagram towards the target in accordance with their respective routing tables.

Sometimes distribution needs individual IP packets be delivered to multiple destinations (like audio or video streaming broadcasts). Multicast is a method of distributing datagrams sourced from one (or possibly more) host(s) to a set of receivers that may be distributed over different (sub) networks. This makes delivery of multicast datagrams significantly more complex.

Multicast sources can send a single copy of data using a single address for the entire group of recipients. The routers between the source and recipients route the data using the group address route. Multicast packets are delivered to a multicast group. A multicast group specifies a set of recipients who are interested in a particular data stream and is represented by an IP address from a specified range. Data addressed to the IP address is forwarded to the members of the group. A source host sends data to a multicast group by specifying the multicast group address in the datagram's destination IP address. A source does not have to register in order to send data to a group nor do they need to be a member of the group.

Routers and Layer 3 switches use the Internet Group Management Protocol (IGMP) to manage membership for a multicast session. When a host wants to receive one or more multicast sessions it will send a join message for each multicast group it wants to join. When a host wants to leave a multicast group, it will send a leave message.

To extend multicast to the Internet, the multicast backbone (Mbone) is used. The Mbone is layered on top of portions of the Internet. These portions, or islands, are interconnected using tunnels. The tunnels allow multicast traffic to pass between the multicast-capable portions of the Internet. As more and more routers in the Internet are multicast-capable (and scalable) the unicast and multicast routing table will converge.

The original Mbone was based on Distance Vector Multicast Routing Protocol (DVMRP) and was very limited. The Mbone is, however, converging around the following protocol set:

- IGMP
- Protocol Independent Multicast (Sparse Mode) (PIM-SM)
- Border Gateway Protocol with multi-protocol extensions (MBGP)
- Multicast Source Discovery Protocol (MSDP)

Multicast Models

Alcatel-Lucent 7750 SRs support two models to provide multicast:

- [Any-Source Multicast \(ASM\) on page 23](#)
 - [Source Specific Multicast \(SSM\) on page 23](#)
-

Any-Source Multicast (ASM)

Any-Source Multicast (ASM) is the IP multicast service model defined in RFC 1112, *Host extensions for IP Multicasting*. An IP datagram is transmitted to a host group, a set of zero or more end-hosts identified by a single IP destination address (224.0.0.0 through 239.255.255.255 for IPv4). End-hosts can join and leave the group any time and there is no restriction on their location or number. This model supports multicast groups with arbitrarily many senders. Any end-host can transmit to a host group even if it is not a member of that group.

To combat the vast complexity and scaling issues that ASM represents, the IETF is developing a service model called Source Specific Multicast (SSM).

Source Specific Multicast (SSM)

The Source Specific Multicast (SSM) service model defines a channel identified by an (S,G) pair, where S is a source address and G is an SSM destination address. In contrast to the ASM model, SSM only provides network-layer support for one-to-many delivery.

The SSM service model attempts to alleviate the following deployment problems that ASM has presented:

- Address allocation — SSM defines channels on a per-source basis. For example, the channel (S1,G) is distinct from the channel (S2,G), where S1 and S2 are source addresses, and G is an SSM destination address. This averts the problem of global allocation of SSM destination addresses and makes each source independently responsible for resolving address collisions for the various channels it creates.
- Access control — SSM provides an efficient solution to the access control problem. When a receiver subscribes to an (S,G) channel, it receives data sent only by the source S. In contrast, any host can transmit to an ASM host group. At the same time, when a sender picks a channel (S,G) to transmit on, it is automatically ensured that no other sender will be transmitting on the same channel (except in the case of malicious acts such as address spoofing). This makes it harder to spam an SSM channel than an ASM multicast group.
- Handling of well-known sources — SSM requires only source-based forwarding trees. This eliminates the need for a shared tree infrastructure. In terms of the IGMP, PIM-SM,

MSDP, MBGP protocol suite, this implies that neither the RP-based shared tree infrastructure of PIM-SM nor the MSDP protocol is required. Thus, the complexity of the multicast routing infrastructure for SSM is low, making it viable for immediate deployment. Note that MBGP is still required for distribution of multicast reachability information.

- Anticipating that point-to-multipoint applications such as Internet TV will be significant in the future, the SSM model is better suited for such applications.

IPv6 Multicast

IPv6 multicast enables multicast applications over native IPv6 networks. There are two service models: Any Source Multicast (ASM) and Source Specific Multicast (SSM) which includes PIM SSM and MLD (v1 and v2). SSM does not require source discovery and only supports single source for a specific multicast stream. As a result, SSM is easier to operate in a large scale deployment that uses the one-to-many service model.

Multicast Listener Discovery (MLD v1 and v2)

MLD is the IPv6 version of IGMP. The purpose of MLD is to allow each IPv6 router to discover the presence of multicast listeners on its directly attached links, and to discover specifically which multicast groups are of interest to those neighboring nodes.

MLD is a sub-protocol of ICMPv6. MLD message types are a subset of the set of ICMPv6 messages, and MLD messages are identified in IPv6 packets by a preceding Next Header value of 58. All MLD messages are sent with a link-local IPv6 source address, a Hop Limit of 1, and an IPv6 Router Alert option in the Hop-by-Hop Options header.

Similar to IGMPv2, MLDv1 reports only include the multicast group addresses that listeners are interested in, and don't include the source addresses. In order to work with PIM SSM model, a similar SSM translation function is required when MLDv1 is used.

SSM translation allows an IGMPv2 device to join an SSM multicast network through the router that provides such a translation capability. Currently SSM translation can be done at a box level, but this does not allow a per-interface translation to be specified. SSM translation per interface offers the ability to have a same (*,G) mapped to two different (S,G) on two different interfaces to provide flexibility.

MLDv2 is backward compatible with MLDv1 and adds the ability for a node to report interest in listening to packets with a particular multicast group only from specific source addresses or from all sources except for specific source addresses.

PIM SSM

The IPv6 address family for SSM model is supported. This includes the ability to choose which RTM table to use (unicast RTM, multicast RTM, or both). OSPF3, IS-IS and static-route have extensions to support submission of routes into the IPv6 multicast RTM.

IPv6 PIM ASM

IPv6 PIM ASM is supported. All PIM ASM related functions such as bootstrap router, RP, etc., support both IPv4 and IPv6 address-families. IPv6 specific parameters are configured under **configure>router>pim>rp>ipv6**.

Embedded RP

The detailed protocol specification is defined in RFC 3956, *Embedding the Rendezvous Point (RP) Address in an IPv6 Multicast Address*. This RFC describes a multicast address allocation policy in which the address of the RP is encoded in the IPv6 multicast group address, and specifies a PIM-SM group-to-RP mapping to use the encoding, leveraging, and extending unicast-prefix-based addressing. This mechanism not only provides a simple solution for IPv6 inter-domain ASM but can be used as a simple solution for IPv6 intra-domain ASM with scoped multicast addresses as well. It can also be used as an automatic RP discovery mechanism in those deployment scenarios that would have previously used the Bootstrap Router protocol (BSR).

Core Router Multicast Requirements

This section describes the multicast requirements when an Alcatel-Lucent 7750 SR is deployed as part of the user's core network.

The required protocol set is as follows:

- Internet Group Management Protocol ([Internet Group Management Protocol on page 27](#))
 - Source Specific Multicast Groups ([SSM on page 29](#))
 - Protocol Independent Multicast (Sparse Mode) ([PIM-SM on page 30](#))
 - Multicast Extensions to MBGP ([Multicast Extensions to MBGP on page 40](#))
-

Internet Group Management Protocol

Internet Group Management Protocol (IGMP) is used by IPv4 hosts and routers to report their IP multicast group memberships to neighboring multicast routers. A multicast router keeps a list of multicast group memberships for each attached network, and a timer for each membership.

Multicast group memberships include at least one member of a multicast group on a given attached network, not a list of all of the members. With respect to each of its attached networks, a multicast router can assume one of two roles, querier or non-querier. There is normally only one querier per physical network.

A querier issues two types of queries, a general query and a group-specific query. General queries are issued to solicit membership information with regard to any multicast group. Group-specific queries are issued when a router receives a leave message from the node it perceives as the last group member remaining on that network segment.

Hosts wanting to receive a multicast session issue a multicast group membership report. These reports must be sent to all multicast enabled routers.

IGMP Versions and Interoperability Requirements

If routers run different versions of IGMP, they will negotiate the lowest common version of IGMP that is supported on their subnet and operate in that version.

Version 1 — Specified in RFC-1112, *Host extensions for IP Multicasting*, was the first widely deployed version and the first version to become an Internet standard.

Version 2 — Specified in RFC-2236, *Internet Group Management Protocol*, added support for “low leave latency”, that is, a reduction in the time it takes for a multicast router to learn that there are no longer any members of a particular group present on an attached network.

Version 3 — Specified in RFC-3376, *Internet Group Management Protocol*, adds support for source filtering, that is, the ability for a system to report interest in receiving packets only from specific source addresses, as required to support Source-Specific Multicast (See Source Specific Multicast (SSM)), or from all but specific source addresses, sent to a particular multicast address.

IGMPv3 must keep state per group per attached network. This group state consists of a filter-mode, a list of sources, and various timers. For each attached network running IGMP, a multicast router records the desired reception state for that network.

IGMP Version Transition

Alcatel-Lucent’s 7750 SR routers are capable of interoperating with routers and hosts running IGMPv1, IGMPv2, and/or IGMPv3. RFC 5186, *Internet Group Management Protocol Version 3 (IGMPv3)/Multicast Listener Discovery Version 2 (MLDv2) and Multicast Routing Protocol Interaction* explores some of the interoperability issues and how they affect the various routing protocols.

IGMP version 3 specifies that if at any point a router receives an older version query message on an interface that it must immediately switch into a compatibility mode with that earlier version. Since none of the previous versions of IGMP are source aware, should this occur and the interface switch to Version 1 or 2 compatibility mode, any previously learned group memberships with specific sources (learned via the IGMPv3 specific INCLUDE or EXCLUDE mechanisms) MUST be converted to non-source specific group memberships. The routing protocol will then treat this as if there is no EXCLUDE definition present.

Source-Specific Multicast Groups

IGMPv3 permits a receiver to join a group and specify that it only wants to receive traffic for a group if that traffic comes from a particular source. If a receiver does this, and no other receiver on the LAN requires all the traffic for the group, then the designated router (DR) can omit performing a (*,G) join to set up the shared tree, and instead issue a source-specific (S,G) join only.

The range of multicast addresses from 232.0.0.0 to 232.255.255.255 is currently set aside for source-specific multicast in IPv4. For groups in this range, receivers should only issue source-specific IGMPv3 joins. If a PIM router receives a non-source-specific join for a group in this range, it should ignore it.

An Alcatel-Lucent 7750 SR PIM router must silently ignore a received (*,G) PIM join message where G is a multicast group address from the multicast address group range that has been explicitly configured for SSM. This occurrence should generate an event. If configured, the IGMPv2 request can be translated into IGMPv3. The 7750 allows for the conversion of an IGMPv2 (*,G) request into a IGMPv3 (S,G) request based on manual entries. A maximum of 32 SSM ranges is supported.

IGMPv3 also permits a receiver to join a group and specify that it only wants to receive traffic for a group if that traffic does not come from a specific source or sources. In this case, the DR will perform a (*,G) join as normal, but can combine this with a prune for each of the sources the receiver does not wish to receive.

Protocol Independent Multicast Sparse Mode (PIM-SM)

PIM-SM leverages the unicast routing protocols that are used to create the unicast routing table, OSPF, IS-IS, BGP, and static routes. Because PIM uses this unicast routing information to perform the multicast forwarding function it is effectively IP protocol independent. Unlike DVMRP, PIM does not send multicast routing tables updates to its neighbors.

PIM-SM uses the unicast routing table to perform the Reverse Path Forwarding (RPF) check function instead of building up a completely independent multicast routing table.

PIM-SM only forwards data to network segments with active receivers that have explicitly requested the multicast group. PIM-SM in the ASM model initially uses a shared tree to distribute information about active sources. Depending on the configuration options, the traffic can remain on the shared tree or switch over to an optimized source distribution tree. As multicast traffic starts to flow down the shared tree, routers along the path determine if there is a better path to the source. If a more direct path exists, then the router closest to the receiver sends a join message toward the source and then reroutes the traffic along this path.

As stated above, PIM-SM relies on an underlying topology-gathering protocol to populate a routing table with routes. This routing table is called the Multicast Routing Information Base (MRIB). The routes in this table can be taken directly from the unicast routing table, or it can be different and provided by a separate routing protocol such as MBGP. Regardless of how it is created, the primary role of the MRIB in the PIM-SM protocol is to provide the next hop router along a multicast-capable path to each destination subnet. The MRIB is used to determine the next hop neighbor to whom any PIM join/prune message is sent. Data flows along the reverse path of the join messages. Thus, in contrast to the unicast RIB that specifies the next hop that a data packet would take to get to some subnet, the MRIB gives reverse-path information, and indicates the path that a multicast data packet would take from its origin subnet to the router that has the MRIB.

PIM-SM Functions

PIM-SM functions in three phases:

- [Phase One on page 31](#)
- [Phase Two on page 31](#)
- [Phase Three on page 32](#)

Phase One

In this phase, a multicast receiver expresses its interest in receiving traffic destined for a multicast group. Typically it does this using IGMP or MLD, but other mechanisms might also serve this purpose. One of the receiver's local routers is elected as the DR for that subnet. When the expression of interest is received, the DR sends a PIM join message towards the RP for that multicast group. This join message is known as a (*,G) join because it joins group G for all sources to that group. The (*,G) join travels hop-by-hop towards the RP for the group, and in each router it passes through the multicast tree state for group G is instantiated. Eventually the (*,G) join either reaches the RP or reaches a router that already has (*,G) join state for that group. When many receivers join the group, their join messages converge on the RP and form a distribution tree for group G that is rooted at the RP. This is known as the RP tree and is also known as the shared tree because it is shared by all sources sending to that group. Join messages are resent periodically as long as the receiver remains in the group. When all receivers on a leaf-network leave the group, the DR will send a PIM (*,G) prune message towards the RP for that multicast group. However if the prune message is not sent for any reason, the state will eventually time out.

A multicast data sender starts sending data destined for a multicast group. The sender's local router (the DR) takes those data packets, unicast-encapsulates them, and sends them directly to the RP. The RP receives these encapsulated data packets, de-encapsulates them, and forwards them onto the shared tree. The packets then follow the (*,G) multicast tree state in the routers on the RP tree, being replicated wherever the RP tree branches, and eventually reaching all the receivers for that multicast group. The process of encapsulating data packets to the RP is called registering, and the encapsulation packets are known as PIM register packets.

At the end of phase one, multicast traffic is flowing encapsulated to the RP, and then natively over the RP tree to the multicast receivers.

Phase Two

In this phase, register-encapsulation of data packets is performed. However, register-encapsulation of data packets is unsuitable for the following reasons:

- Encapsulation and de-encapsulation can be resource intensive operations for a router to perform depending on whether or not the router has appropriate hardware for the tasks.
- Traveling to the RP and then back down the shared tree can cause the packets to travel a relatively long distance to reach receivers that are close to the sender. For some applications, increased latency is unwanted.

Although register-encapsulation can continue indefinitely, for these reasons, the RP will normally switch to native forwarding. To do this, when the RP receives a register-encapsulated data packet from source S on group G, it will normally initiate an (S,G) source-specific join towards S. This join message travels hop-by-hop towards S, instantiating (S,G) multicast tree state in the routers along the path. (S,G) multicast tree state is used only to forward packets for group G if those

Core Router Multicast Requirements

packets come from source S. Eventually the join message reaches S's subnet or a router that already has (S,G) multicast tree state, and then packets from S start to flow following the (S,G) tree state towards the RP. These data packets can also reach routers with (*,G) state along the path towards the RP - if so, they can short-cut onto the RP tree at this point.

While the RP is in the process of joining the source-specific tree for S, the data packets will continue being encapsulated to the RP. When packets from S also start to arrive natively at the RP, the RP will be receiving two copies of each of these packets. At this point, the RP starts to discard the encapsulated copy of these packets and it sends a register-stop message back to S's DR to prevent the DR unnecessarily encapsulating the packets. At the end of phase 2, traffic will be flowing natively from S along a source-specific tree to the RP and from there along the shared tree to the receivers. Where the two trees intersect, traffic can transfer from the shared RP tree to the shorter source tree.

Note that a sender can start sending before or after a receiver joins the group, and thus, phase two may occur before the shared tree to the receiver is built.

Phase Three

In this phase, the RP joins back towards the source using the shortest path tree. Although having the RP join back towards the source removes the encapsulation overhead, it does not completely optimize the forwarding paths. For many receivers the route via the RP can involve a significant detour when compared with the shortest path from the source to the receiver.

To obtain lower latencies, a router on the receiver's LAN, typically the DR, may optionally initiate a transfer from the shared tree to a source-specific shortest-path tree (SPT). To do this, it issues an (S,G) Join towards S. This instantiates state in the routers along the path to S. Eventually this join either reaches S's subnet or reaches a router that already has (S,G) state. When this happens, data packets from S start to flow following the (S,G) state until they reach the receiver.

At this point the receiver (or a router upstream of the receiver) will be receiving two copies of the data - one from the SPT and one from the RPT. When the first traffic starts to arrive from the SPT, the DR or upstream router starts to drop the packets for G from S that arrive via the RP tree. In addition, it sends an (S,G) prune message towards the RP. The prune message travels hop-by-hop instantiating state along the path towards the RP indicating that traffic from S for G should NOT be forwarded in this direction. The prune message is propagated until it reaches the RP or a router that still needs the traffic from S for other receivers.

By now, the receiver will be receiving traffic from S along the shortest-path tree between the receiver and S. In addition, the RP is receiving the traffic from S, but this traffic is no longer reaching the receiver along the RP tree. As far as the receiver is concerned, this is the final distribution tree.

Encapsulating Data Packets in the Register Tunnel

Conceptually, the register tunnel is an interface with a smaller MTU than the underlying IP interface towards the RP. IP fragmentation on packets forwarded on the register tunnel is performed based upon this smaller MTU. The encapsulating DR can perform path-MTU discovery to the RP to determine the effective MTU of the tunnel. This smaller MTU takes both the outer IP header and the PIM register header overhead into consideration.

PIM Bootstrap Router Mechanism

For proper operation, every PIM-SM router within a PIM domain must be able to map a particular global-scope multicast group address to the same RP. If this is not possible, then black holes can appear (this is where some receivers in the domain cannot receive some groups). A domain in this context is a contiguous set of routers that all implement PIM and are configured to operate within a common boundary.

The bootstrap router (BSR) mechanism provides a way in which viable group-to-RP mappings can be created and distributed to all the PIM-SM routers in a domain. Each candidate BSR originates bootstrap messages (BSMs). Every BSM contains a BSR priority field. Routers within the domain flood the BSMs throughout the domain. A candidate BSR that hears about a higher-priority candidate BSR suppresses its sending of further BSMs for a period of time. The single remaining candidate BSR becomes the elected BSR and its BSMs inform the other routers in the domain that it is the elected BSR.

It is adaptive, meaning that if an RP becomes unreachable, it will be detected and the mapping tables will be modified so the unreachable RP is no longer used and the new tables will be rapidly distributed throughout the domain.

PIM-SM Routing Policies

Multicast traffic can be restricted from certain source addresses by creating routing policies. Join messages can be filtered using import filters. PIM join policies can be used to reduce denial of service attacks and subsequent PIM state explosion in the router and to remove unwanted multicast streams at the edge of the network before it is carried across the core. Route policies are created in the `config>router>policy-options` context. See [Configuring PIM Join/Register Policies on page 766](#).

Join and register route policy match criteria for PIM-SM can specify the following:

- Router interface or interfaces specified by name or IP address.
- Neighbor address (the source address in the IP header of the join and prune message).
- Multicast group address embedded in the join and prune message.

Core Router Multicast Requirements

- Multicast source address embedded in the join and prune message.

Join policies can be used to filter PIM join messages so no *,G or S,G state will be created on the router.

Table 2: Join Filter Policy Match Conditions

Match Condition	Matches the:
Interface	RTR interface by name
Neighbor	The neighbors source address in the IP header
Group Address	Multicast Group address in the join/prune message
Source Address	Source address in the join/prune message

PIM register message are sent by the first hop designated router that has a direct connection to the source. This serves a dual purpose:

- Notifies the RP that a source has active data for the group
- Delivers the multicast stream in register encapsulation to the RP and its potential receivers.
- If no one has joined the group at the RP, the RP will ignore the registers.

In an environment where the sources to particular multicast groups are always known, it is possible to apply register filters at the RP to prevent any unwanted sources from transmitting multicast stream. You can apply these filters at the edge so that register data does not travel unnecessarily over the network towards the RP.

Table 3: Register Filter Policy Match Conditions

Match Condition	Matches the:
Interface	RTR interface by name
Group Address	Multicast Group address in the join/prune message
Source Address	Source address in the join/prune message

Reverse Path Forwarding Checks

Multicast implements a reverse path forwarding check (RPF). RPF checks the path that multicast packets take between their sources and the destinations to prevent loops. Multicast requires that an incoming interface is the outgoing interface used by unicast routing to reach the source of the multicast packet. RPF forwards a multicast packet only if it is received on an interface that is used by the router to route to the source.

If the forwarding paths are modified due to routing topology changes then any dynamic filters that may have been applied must be re-evaluated. If filters are removed then the associated alarms are also cleared.

Anycast RP for PIM-SM

The implementation of Anycast RP for PIM-SM environments enable fast convergence when a PIM rendezvous point (RP) router fails by allowing receivers and sources to rendezvous at the closest RP. It allows an arbitrary number of RPs per group in a single shared-tree protocol Independent Multicast-Sparse Mode (PIM-SM) domain. This is, in particular, important for triple play configurations that opt to distribute multicast traffic using PIM-SM, not SSM. In this case, RP convergence must be fast enough to avoid the loss of multicast streams which could cause loss of TV delivery to the end customer.

Anycast RP for PIM-SM environments is supported in the base routing/PIM-SM instance of the service router. In the 7710 SR and 7750 SR product lines, this feature is supported in Layer 3-VPRN instances that are configured with PIM.

Implementation

The Anycast RP for PIM-SM implementation is defined in *draft-ietf-pim-anycast-rp-03*, *Anycast-RP using PIM*, and is similar to that described in RFC 3446, *Anycast RP Mechanism Using PIM and MSDP*, and extends the register mechanism in PIM so Anycast RP functionality can be retained without using Multicast Source Discovery Protocol (MSDP) (see [on page 41](#)).

The mechanism works as follows:

- An IP address is chosen to use as the RP address. This address is statically configured, or distributed using a dynamic protocol, to all PIM routers throughout the domain.
- A set of routers in the domain are chosen to act as RPs for this RP address. These routers are called the Anycast-RP set.
- Each router in the Anycast-RP set is configured with a loopback interface using the RP address.
- Each router in the Anycast-RP set also needs a separate IP address to be used for communication between the RPs.
- The RP address, or a prefix that covers the RP address, is injected into the unicast routing system inside of the domain.
- Each router in the Anycast-RP set is configured with the addresses of all other routers in the Anycast-RP set. This must be consistently configured in all RPs in the set.

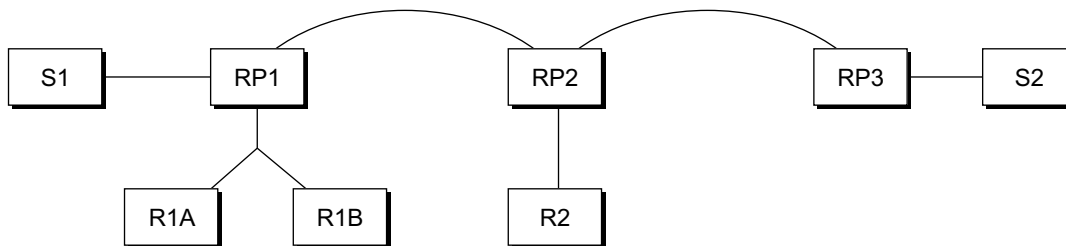

OSSG271

Figure 1: Anycast RP for PIM-SM Implementation Example

Assume the scenario in [Figure 1](#) is completely connected where R1A, R1B, and R2 are receivers for a group, and S1 and S2 send to that group. Assume RP1, RP2, and RP3 are all assigned the same IP address which is used as the Anycast-RP address (for example, the IP address is RPA).

Note, the address used for the RP address in the domain (the Anycast-RP address) must be different than the addresses used by the Anycast-RP routers to communicate with each other.

The following procedure is used when S1 starts sourcing traffic:

- S1 sends a multicast packet.
- The DR directly attached to S1 will form a PIM register message to send to the Anycast-RP address (RPA). The unicast routing system will deliver the PIM register message to the nearest RP, in this case RP1A.
- RP1 will receive the PIM register message, de-encapsulate it, send the packet down the shared-tree to get the packet to receivers R1A and R1B.
- RP1 is configured with RP2 and RP3's IP address. Since the register message did not come from one of the RPs in the anycast-RP set, RP1 assumes the packet came from a DR. If the register message is not addressed to the Anycast-RP address, an error has occurred and it should be rate-limited logged.
- RP1 will then send a copy of the register message from S1's DR to both RP2 and RP3. RP1 will use its own IP address as the source address for the PIM register message.
- RP1 may join back to the source-tree by triggering a (S1,G) Join message toward S1. However, RP1 must create (S1,G) state.
- RP2 receives the register message from RP1, de-encapsulates it, and also sends the packet down the shared-tree to get the packet to receiver R2.
- RP2 sends a register-stop message back to the RP1. RP2 may wait to send the register-stop message if it decides to join the source-tree. RP2 should wait until it has received data from the source on the source-tree before sending the register-stop message. If RP2

Core Router Multicast Requirements

decides to wait, the register-stop message will be sent when the next register is received. If RP2 decides not to wait, the register-stop message is sent now.

- RP2 may join back to the source-tree by triggering a (S1,G) Join message toward S1. However, RP2 must create (S1,G) state.
- RP3 receives the register message from RP1, de-encapsulates it, but since there are no receivers joined for the group, it can discard the packet.
- RP3 sends a register-stop message back to the RP1.
- RP3 creates (S1,G) state so when a receiver joins after S1 starts sending, RP3 can join quickly to the source-tree for S1.
- RP1 processes the register-stop message from each of RP2 and RP3. RP1 may cache on a per-RP/per-(S,G) basis the receipt of register-stop message messages from the RPs in the anycast-RP set. This option is performed to increase the reliability of register message delivery to each RP. When this option is used, subsequent register messages received by RP1 are sent only to the RPs in the Anycast-RP set which have not previously sent register-stop message messages for the (S,G) entry.
- RP1 sends a register-stop message back to the DR the next time a register message is received from the DR and (when the option in the last bullet is in use) if all RPs in the Anycast-RP set have returned register-stop messages for a particular (S,G) route.

The procedure for S2 sending follows the same as above but it is RP3 which sends a copy of the register originated by S2's DR to RP1 and RP2. Therefore, this example shows how sources anywhere in the domain, associated with different RPs, can reach all receivers, also associated with different RPs, in the same domain.

Auto-RP (discovery mode only) in Multicast VPN

Auto-RP is a vendor proprietary protocol to dynamically learn about availability of Rendezvous Point (RP) in network. Auto-RP protocol consists of announcing, mapping and discovery functions. SROS supports the discovery mode of Auto-RP that includes mapping and forwarding of RP-mapping and RP-candidate messages. Discovery mode also includes receiving RP-mapping messages locally to learn and maintain RP-candidate database.

Auto-RP protocol is supported with multicast VPN and global routing instance. Either BSR or Auto-RP is allowed to be configured per routing instance. Both mechanisms cannot be enabled together.

Multicast Extensions to MBGP

This section describes the implementation of extensions to MBGP to support multicast. Rather than assuming that all unicast routes are multicast-capable, some routed environments, in some cases, some ISPs do not support or have limited support for multicast throughout their AS.

BGP is capable of supporting two sets of routing information, one set for unicast routing and the other for multicast routing. The unicast and multicast routing sets either partially or fully overlay one another. To achieve this, BGP has added support for IPv4 and mcast-IPv4 address families. Routing policies can be imported or exported.

The multicast routing information can subsequently be used by the Protocol Independent Multicast (PIM) protocol to perform its Reverse Path Forwarding (RPF) lookups for multicast-capable sources. Thus, multicast traffic can only be routed across a multicast topology and not a unicast topology.

MBGP Multicast Topology Support

Recursive Lookup for BGP Next Hops

The next hop for multicast RPF routes learned by MBGP is not always the address of a directly-connected neighbor. For unicast routing, a router resolves the directly-connected next-hop by repeating the IGP routes. For multicast RPF routes, there are different ways to find the real next-hops.

- Scanning to see if a route encompasses the BGP next hop. If one exists, this route is used. If not, the tables are scanned for the best matching route.
- Check to see if the recursed next hop is taken from the protocol routing table with the lowest administrative distance (protocol preference). This means that the operating system algorithm must perform multiple lookups in the order of the lowest admin distance. Note that unlike recursion on the unicast routing table, the longest prefix match rule does not take effect; protocol preference is considered prior to prefix length. For example, the route 12.0.0.0/14 learned via MBGP will be selected over the route 12.0.0.0/16 learned via BGP.

Multicast Source Discovery Protocol (MSDP)

MSDP-speaking routers in a PIM-SM (RFC 2362, *Protocol Independent Multicast-Sparse Mode (PIM-SM): Protocol Specification*) domain have MSDP peering relationship with MSDP peers in another domain. The peering relationship is made up of a TCP connection in which control information is exchanged. Each domain has one or more connections to this virtual topology.

When a PIM-SM RP learns about a new multicast source within its own domain from a standard PIM register mechanism, it encapsulates the first data packet in an MSDP source-active message and sends it to all MSDP peers.

The source-active message is flooded (after an RPF check) by each peer to its MSDP peers until the source-active message reaches every MSDP router in the interconnected networks. If the receiving MSDP peer is an RP, and the RP has a (*.G) entry (receiver) for the group, the RP creates state for the source and joins to the shortest path tree for the source. The encapsulated data is de-encapsulated and forwarded down the shared tree of that RP. When the packet is received by the last hop router of the receiver, the last hop router also may join the shortest path tree to the source.

The MSDP speaker periodically sends source-active messages that include all sources.

Anycast RP for MSDP

MSDP is a mechanism that allows rendezvous points to share information about active sources. When RPs in remote domains hear about the active sources, they can pass on that information to the local receivers and multicast data can be forwarded between the domains. MSDP allows each domain to maintain an independent RP that does not rely on other domains but enables RPs to forward traffic between domains. PIM-SM is used to forward the traffic between the multicast domains.

Using PIM-SM, multicast sources and receivers register with their local RP by the closest multicast router. The RP maintains information about the sources and receivers for any particular group. RPs in other domains do not have any knowledge about sources located in other domains.

MSDP is required to provide inter-domain multicast services using Any Source Multicast (ASM). Anycast RP for MSDP enables fast convergence when should an MSDP/PIM PR router fail by allowing receivers and sources to rendezvous at the closest RP.

MSDP Procedure

When an RP in a PIM-SM domain first learns of a new sender, for example, by PIM register messages, it constructs a source-active (SA) message and sends it to its MSDP peers. The SA message contains the following fields:

- Source address of the data source
- Group address the data source sends to
- IP address of the RP

Note that an RP that is not a designated router on a shared network do not originate SAs for directly-connected sources on that shared network. It only originates in response to receiving register messages from the designated router.

Each MSDP peer receives and forwards the message away from the RP address in a peer-RPF flooding fashion. The notion of peer-RPF flooding is with respect to forwarding SA messages. The Multicast RPF Routing Information Base (MRIB) is examined to determine which peer towards the originating RP of the SA message is selected. Such a peer is called an RPF peer.

If the MSDP peer receives the SA from a non-RPF peer towards the originating RP, it will drop the message. Otherwise, it forwards the message to all its MSDP peers (except the one from which it received the SA message).

When an MSDP peer which is also an RP for its own domain receives a new SA message, it determines if there are any group members within the domain interested in any group described by an (S,G) entry within the SA message. That is, the RP checks for a (*,G) entry with a non-empty outgoing interface list. This implies that some system in the domain is interested in the group. In this case, the RP triggers an (S,G) join event toward the data source as if a join/prune message was received addressed to the RP. This sets up a branch of the source-tree to this domain. Subsequent data packets arrive at the RP by this tree branch and are forwarded down the shared-tree inside the domain. If leaf routers choose to join the source-tree they have the option to do so according to existing PIM-SM conventions. If an RP in a domain receives a PIM join message for a new group G, the RP must trigger an (S,G) join event for each active (S,G) for that group in its SA cache.

This procedure is called flood-and-join because if any RP is not interested in the group, the SA message can be ignored, otherwise, they join a distribution tree.

MSDP Peering Scenarios

Draft-ietf-mboned-msdp-deploy-nn.txt, *Multicast Source Discovery Protocol (MSDP) Deployment Scenarios*, describes how protocols work together to provide intra- and inter-domain ASM service.

Inter-domain peering:

- Peering between PIM border routers (single-hop peering)
- Peering between non-border routers (multi-hop peering)
- MSDP peering without BGP
- MSDP peering between mesh groups
- MSDP peering at a multicast exchange

Intra-domain peering:

- Peering between routers configured for both MSDP and MBGP
 - MSDP peer is not BGP peer (meaning, no BGP peer)
-

MSDP Peer Groups

MSDP peer groups are typically created when multiple peers have a set of common operational parameters. Group parameters not specifically configured are inherited from the global level.

MSDP Mesh Groups

MSDP mesh groups are used to reduce source active flooding primarily in intra-domain configurations. When a number of speakers in an MSDP domain are fully meshed they can be configured as a mesh group. The originator of the source active message forwards the message to all members of the mesh group. Because of this, forwarding the SA between non-originating members of the mesh group is not necessary.

MSDP Routing Policies

MSDP routing policies allow for filtering of inbound and/or outbound active source messages. Policies can be configured at different levels:

- Global level — Applies to all peers
- Group level — Applies to all peers in peer-group
- Neighbor level — Applies only to specified peer

The most specific level is used. If multiple policy names are specified, the policies are evaluated in the order they are specified. The first policy that matches is applied. If no policy is applied source active messages are passed.

Match conditions include:

- Neighbor — Matches on a neighbor address is the source address in the IP header of the source active message.
- Route filter — Matches on a multicast group address embedded in the source active message
- Source address filter — Matches on a multicast source address embedded in the source active message

Multicast in Virtual Private Networks

Draft Rosen

RFC2547bis, *BGP/MPLS IP VPNs*, describes a method of providing a VPN service. A VPN provides secure connections to the network, allowing more efficient service to remote users without compromising the security of firewalls. The Rosen draft specifies the protocols and procedures which must be implemented in order for a service provider to provide a unicast VPN. The draft extends that specification by describing the protocols and procedures which a service provider must implement in order to support multicast traffic in a VPN, assuming that PIM [PIMv2] is the multicast routing protocol used within the VPN, and the SP network can provide PIM as well.

IGMP is not supported for receivers or senders directly attached to the PE.

For further information, refer to the Virtual Private Routed Network Service section of the 7750 SR OS Services Guide.

Multicast Debugging Tools

This section describes multicast debugging tools requirement for the 7750 SR family of products.

The debugging tools for multicast consist out of three elements; mtrace, mstat, and mrinfo.

Mtrace

Assessing problems in the distribution of IP multicast traffic can be difficult. The **mtrace** feature utilizes a tracing feature implemented in multicast routers that is accessed via an extension to the IGMP protocol. The **mtrace** feature is used to print the path from the source to a receiver; it does this by passing a trace query hop-by-hop along the reverse path from the receiver to the source. At each hop, information such as the hop address, routing error conditions and packet statistics should be gathered and returned to the requestor.

Data added by each hop includes:

- Query arrival time
- Incoming interface
- Outgoing interface
- Previous hop router address
- Input packet count
- Output packet count
- Total packets for this source/group
- Routing protocol
- TTL threshold
- Forwarding/error code

The information enables the network administrator to determine:

- Where multicast flows stop
- the flow of the multicast stream

When the trace response packet reaches the first hop router (the router that is directly connected to the source's net), that router sends the completed response to the response destination (receiver) address specified in the trace query.

If some multicast router along the path does not implement the multicast traceroute feature or if there is some outage, then no response is returned. To solve this problem, the trace query includes

a maximum hop count field to limit the number of hops traced before the response is returned. This allows a partial path to be traced.

The reports inserted by each router contain not only the address of the hop, but also the TTL required to forward and some flags to indicate routing errors, plus counts of the total number of packets on the incoming and outgoing interfaces and those forwarded for the specified group. Taking differences in these counts for two traces separated in time and comparing the output packet counts from one hop with the input packet counts of the next hop allows the calculation of packet rate and packet loss statistics for each hop to isolate congestion problems.

Finding the Last Hop Router

The trace query must be sent to the multicast router which is the last hop on the path from the source to the receiver. If the receiver is on the local subnet (as determined using the subnet mask), then the default method is to multicast the trace query to all-routers.mcast.net (224.0.0.2) with a TTL of 1. Otherwise, the trace query is multicast to the group address since the last hop router will be a member of that group if the receiver is. Therefore, it is necessary to specify a group that the intended receiver has joined. This multicast is sent with a default TTL of 64, which may not be sufficient for all cases.

When tracing from a multihomed host or router, the default receiver address may not be the desired interface for the path from the source. In that case, the desired interface should be specified explicitly as the receiver.

Directing the Response

By default, mtrace first attempts to trace the full reverse path, unless the number of hops to trace is explicitly set with the hop option. If there is no response within a 3 second timeout interval, a "*" is printed and the probing switches to hop-by-hop mode. Trace queries are issued starting with a maximum hop count of one and increasing by one until the full path is traced or no response is received. At each hop, multiple probes are sent. The first attempt is made with the unicast address of the host running mtrace as the destination for the response. Since the unicast route may be blocked, the remainder of attempts request that the response be multicast to mtrace.mcast.net (224.0.1.32) with the TTL set to 32 more than what's needed to pass the thresholds seen so far along the path to the receiver. For the last attempts the TTL is increased by another 32.

Alternatively, the TTL may be set explicitly with the TTL option.

For each attempt, if no response is received within the timeout, a "*" is printed. After the specified number of attempts have failed, mtrace will try to query the next hop router with a DVMRP_ASK_NEIGHBORS2 request (as used by the mrinfo program) to determine the router type.

Core Router Multicast Requirements

The output of `mtrace` is a short listing of the hops in the order they are queried, that is, in the reverse of the order from the source to the receiver. For each hop, a line is printed showing the hop number (counted negatively to indicate that this is the reverse path); the multicast routing protocol; the threshold required to forward data (to the previous hop in the listing as indicated by the up-arrow character); and the cumulative delay for the query to reach that hop (valid only if the clocks are synchronized). The response ends with a line showing the round-trip time which measures the interval from when the query is issued until the response is received, both derived from the local system clock.

Mtrace/mstat packets use special IGMP packets with IGMP type codes of 0x1E and 0x1F.

Mstat

The **mstat** command adds the capability to show the multicast path in a limited graphic display and provide drops, duplicates, TTLs and delays at each node. This information is useful to the network operator because it identifies nodes with high drop & duplicate counts. Duplicate counts are shown as negative drops.

The output of **mstat** provides a limited pictorial view of the path in the forward direction with data flow indicated by arrows pointing downward and the query path indicated by arrows pointing upward. For each hop, both the entry and exit addresses of the router are shown if different, along with the initial ttl required on the packet in order to be forwarded at this hop and the propagation delay across the hop assuming that the routers at both ends have synchronized clocks. The output consists of two columns, one for the overall multicast packet rate that does not contain lost/sent packets and a column for the (S,G)-specific case. The S,G statistics do not contain lost/sent packets.

Mrinfo

mrinfo is a simple mechanism based on the **ask_neighbors igmp** to display the configuration information from the target multicast router. The type of information displayed includes the Multicast capabilities of the router, code version, metrics, ttl-thresholds, protocols and status. This information, for instance, can be used by network operators to verify if bi-directional adjacencies exist. Once the specified multicast router responds, the configuration is displayed.

Multicast Connection Admission Control (MCAC)

Inspired by network deployments targeted at Ethernet-based triple play aggregation for residential customers, the 7750 has implemented support for Broadcast TV (BTV) distribution. Distribution of BTV services can be facilitated in different ways, such as:

- PIM-SSM based distribution of the channels on a 7750 SR aggregation network, with dynamic IGMP joins from the connected DSLAMs.
- IP-VPN based video distribution.

The capacity taken by the BTV channels may exceed the capacity of the 7750s to access node link (the second mile) or even the capacity of specific network links in the aggregation network (the third mile and fourth mile links). In this case, MCAC has been implemented to limit the amount of bandwidth consumed by BTV services on these links. As the bandwidth constraint can be on the second-mile link and/or on any network link, the multicast CAC function is applicable to any given interface for both IGMP and PIM, and in case of BTV distribution based on VPLS, on VPLS SAPs and SDPs, where IGMP snooping is enabled.

BTV

Broadcast TV (BTV) is the delivery of TV channels by means of multicast or broadcast to many subscribers at the same time (for example, your standard network television channels). BTV is different from Video On Demand (VOD) as this method is delivered by unicast to specific subscribers.

The capacity taken by the BTV channels may exceed the capacity of the 7750s to access node link (the second mile) or even the capacity of specific network links in the aggregation network (the third mile and fourth mile links).

Potentially, running the multicast CAC function might cause specific channels to be temporarily unavailable to subscribers when overloaded. However, the degradation of the quality of the BTV service offering is avoided.

Overbooking BTV video channels in Telco networks follows the MSO trend regarding “switched broadcasts” where digital broadcast programming is only offered to those nodes where and when subscribers actively request that programming. In other words, BTV channels are offered in an on-demand manner rather than being available at all times on the cable network (which is currently typical). This method enables the creation of a virtual programming capacity without the correlated physical expense of creating and dedicating spectral resources. This trend in the MSO space, that now gets ported in the Telco space, is motivated by planned expansions of the BTV programming lineups, particularly those in bandwidth-hungry high definition television format.

Core Router Multicast Requirements

The SR OS (R3.0 and later) allows for some form of CAC for BTV, as it allows limiting the maximum number of channels that can be distributed on a given IP interface (for IGMP and PIM) or VPLS SAP/SDP (with IGMP-snooping). However, this level of control, basically first-come-first-service, is not sufficient in an environment where not all channels are equal in their priority and bandwidth usage.

- Simply performing CAC based on a number of channels does not effectively limit the amount of bandwidth consumed by BTV on any given link as there may be a mix of Standard Definition (SD) and High Definition (HD) channels being offered, or mix of MPEG2/MPEG4 SD channels.

To accommodate BTV CAC requirements, the 7750 implements multicast CAC policies that can be applied to an IP interface or VPLS SAP/SDPs. This allows:

- Definition of BTV bundles:
 - Grouping of MC-group addresses into bundles. Each MC channel can only belong to one specific bundle within the context of one specific policy.
 - Characterization of channels:
 - Bandwidth — Allows differentiation between, for example, SD and HD channels, MPEG2 and MPEG4.
 - Channel type — Either mandatory (can never be blocked, and therefore the CAC algorithm assumes that the bandwidth is permanently reserved) or optional (subject to CAC. This may be temporarily unavailable in times of congestion.).
 - Channel class — For LAG, the class parameter allows further prioritizing of the mandatory or optional channels. This brings the number of priority levels to four during reshuffles of the joined channels when LAG ports are changing state.
- CAC constraints:
 - Interface — Defines constraints on the total amount of bandwidth allowed for BTV on a given IP interface for VPLS SAP/SDP entities.
 - Bundle constraints — Defines constraints on amount of bandwidth per bundle that is allowed on a given IP interface or VPLS SAP/SDP entities.
 - Note that the constraint of the total amount of multicast traffic per channel class is implicit.
 - CAC constraints take into account the potential use of LAG on access or network ports.

Based on these constraints, 7750 multicast CAC can accept or refuse individual IGMP/PIM joins received on such interface (ingress CAC).

It is important to realize that all CAC functionality is based on configuration rather than measured/real bandwidth.

[Table 4](#) displays an example configuration. [Table 5](#) displays CAC constraints.

Table 4: Bundle definition and Channel Characterization

BTV Channel	Bandwidth in Mbps	Channel Type	Channel Class	Bundle
224.1.1.1	4,0	Mandatory	High	1
224.1.1.6	14,0	Optional	Low	2
...

Table 5: CAC Constraints

	Allowed Bandwidth in Mbps
Interface	750
Bundle 1	580
Bundle 2	634
...	...

CAC Algorithm

The multicast CAC algorithm only applies to:

- Channels that have not yet been distributed and that are characterized as optional. Bandwidth for channels characterized as mandatory is pre-reserved on the bundle level and configured on interface level. Channels that are already being distributed will not be dropped.
- Channels specified in the CAC policy. Multicast channels not specified in the CAC policy are not subject to multicast CAC. Treatment of such unspecified channels is configurable as either **accept** or **discard**.

The CAC algorithm is applied at both the interface level and the bundle level CAC constraints specified in the policy. Both checks must pass before the channel is allowed.

When evaluating the channels to forward when starting the policy, the available bandwidth fairness between different bundles is maintained and the following applies:

Mandatory high bundle-1, Mandatory high bundle-2, Mandatory high bundle-3, Mandatory high bundle, and so on.

Then:

Mandatory low bundle-1, Mandatory low bundle-2, Mandatory low bundle-3, Mandatory low bundle, and so on.

Then:

Optional high bundle-1, Optional high bundle-2, Optional high bundle-3, Optional high bundle, and so on.

Then:

Optional low bundle-1, Optional low bundle-2, Optional low bundle-3, Optional low bundle, and so on.

This method does not guarantee that all bundles are fully allocated while others are not. However it does ensure that all mandatory high channels are allocated before any mandatory lows are allocated.

Interface-Level CAC

Interface-level CAC constraints are applied to the interface on which the request was received.

The channel is allowed if:

- The channel is characterized as mandatory and the bandwidth for the already distributed mandatory channels plus the bandwidth of this mandatory channel is not greater than the configured amount of mandatory bandwidth.
- The channel is characterized as optional and the bandwidth for the already distributed optional channels plus the bandwidth of this optional channel is not greater than the configured amount of unconstrained-bw, the configured amount of mandatory bandwidth.

No bandwidth (channels) can be allocated once the configured maximum bandwidth for a given interface has been exceeded.

Bundle-Level CAC

Bundle-level CAC is applied to the bundle to which the channel belongs that triggered the CAC algorithm.

The channel is allowed if:

- When it is characterized as mandatory
 - When it is an optional channel then the configured bundle bandwidth cannot get exceeded by the distributed bandwidth. The distributed bandwidth equals the bandwidth of all the mandatory channels belonging to that bundle plus the bandwidth of the optional channels being distributed plus the bandwidth of the optional channel that want to join.
-

Dealing with Configuration Changes

The system handles changes in the BTV bundle definition and CAC constraints efficiently, without dropping any active channels (even when the constraints have become more stringent).

More stringent constraint examples are:

- An operator adds additional mandatory channels to the BTV bundle definition (in which bandwidth needs to be pre-reserved).
- An operator changes a currently inactive channel from an optional to a mandatory state.
- An operator reduces the allowed bandwidth for one of the bundles or at the interface level.

Core Router Multicast Requirements

- An operator moves channels between bundles.

When these changes become active, all currently active channels continue to be forwarded until they are explicitly released. Channels are not dropped as a result of such policy changes. Additional joins for optional channels are refused until sufficient bandwidth is available to support the more stringent constraints, at which point they become active. Additional joins for existing mandatory channels are never refused.

If a new mandatory channel is defined, or if a currently inactive channel is reconfigured from optional to mandatory, then it will not become active and joins for it will be refused until sufficient bandwidth is available on the link and bundle to enable it.

If the allowed bandwidth is reduced at the interface or bundle level, all active channels are maintained. New joins for optional channels are refused until the new levels are reached.

Distributing PIM Joins over Multiple ECMP Paths

Commonly used multicast load-balancing method is per bandwidth/round robin, but the interface in an ECMP set can also be used for a particular channel to be predictable without knowing anything about the other channels using the ECMP set.

The **mc-ecmp-hashing-enabled** command enables PIM joins to be distributed over the multiple ECMP paths based on a hash of S and G. When a link in the ECMP set is removed, the multicast streams that were using that link are re-distributed over the remaining ECMP links using the same hash algorithm. When a link is added to the ECMP set, new joins may be allocated to the new link based on the hash algorithm, but existing multicast streams using the other ECMP links stay on those links until they are pruned.

The default is **no mc-ecmp-hashing-enabled**, which means that the use of multiple ECMP paths (if enabled at the config>service>vprn context) is controlled by the existing implementation and CLI commands, that is, **mc-ecmp-balance**.

The **mc-ecmp-hasing-enabled** command is mutually exclusive with the **mc-ecmp-balance** command in the same context.

To achieve distribution of streams across the ECMP links, following are the hashings steps :

1. For a given S, G get all possible nHops.
2. Sort these nHops based on nhops address.
3. xor S and G addresses.
4. Hash the xor address over number of pim next hops.
5. Use the hash value obtained in stip 4, and get that element, in the sorted list, we obtained in step 2 as the preferred nHop.
6. If this element is not available/is not a pim Next hop (pim neighbor), the next available next hop is chosen.

The following example displays pim status indicating ECMP Hashing is disabled

```
*B:BB# show router 100 pim status
=====
PIM Status ipv4
=====
Admin State           : Up
Oper State            : Up

IPv4 Admin State     : Up
IPv4 Oper State      : Up

BSR State             : Accept Any
```

Core Router Multicast Requirements

```
Elected BSR
  Address           : None
  Expiry Time      : N/A
  Priority          : N/A
  Hash Mask Length : 30
  Up Time          : N/A
  RPF Intf towards E-BSR : N/A
```

```
Candidate BSR
  Admin State      : Down
  Oper State       : Down
  Address          : None
  Priority         : 0
  Hash Mask Length : 30
```

```
Candidate RP
  Admin State      : Down
  Oper State       : Down
  Address          : 0.0.0.0
  Priority         : 192
  Holdtime        : 150
```

```
SSM-Default-Range : Enabled
SSM-Group-Range   : None
```

```
MC-ECMP-Hashing   : Disabled
```

```
Policy            : None
```

```
RPF Table         : rtable-u
```

```
Non-DR-Attract-Traffic : Disabled
```

```
=====
```

```
-----
*B:BB>config>service>vprn>pim# no mc-ecmp-balance mc-ecmp-balance mc-ecmp-balance-hold
*B:BB>config>service>vprn>pim# no mc-ecmp-balance
*B:BB>config>service>vprn>pim# mc-ecmp-mc-ecmp-balance mc-ecmp-balance-hold mc-ecmp-hash-
ing-enabled
*B:BB>config>service>vprn>pim# mc-ecmp-hashing-enabled
*B:BB>config>service>vprn>pim# info
-----
```

```
      apply-to all
      rp
      static
      address 3.3.3.3
      group-prefix 224.0.0.0/4
      exit
      exit
      bsr-candidate
      shutdown
      exit
      rp-candidate
      shutdown
      exit
      exit
      no mc-ecmp-balance
      mc-ecmp-hashing-enabled
```



```

-----
*B:BB>config>service>vprn>pim#
apply-to          - Create/remove interfaces in PIM
[no] import       - Configure import policies
[no] interface    + Configure PIM interface
[no] mc-ecmp-balance - Enable/Disable multicast balancing of traffic over ECMP links
[no] mc-ecmp-balanc* - Configure hold time for multicast balancing over ECMP links
[no] mc-ecmp-hashin* - Enable/Disable hash based multicast balancing of traffic over ECMP
links
[no] non-dr-attract* - Enable/disable attracting traffic when not DR
rp               + Configure the router as static or Candidate-RP
[no] shutdown     - Administratively enable or disable the operation of PIM
[no] spt-switchover* - Configure shortest path tree (spt tree) switchover threshold for a
group prefix
[no] ssm-default-ra* - Enable the disabling of SSM Default Range
[no] ssm-groups   + Configure the SSM group ranges

```

The following example shows distribution of PIM joins over multiple ECMP paths.

```
*A:BA# show router 100 pim group
```

```

=====
PIM Groups ipv4
=====
Group Address          Type      Spt Bit Inc Intf      No.Oifs
Source Address        RP
-----
225.1.1.1              (S,G)    spt    to_C0      1
170.0.100.33          10.20.1.6
225.1.1.2              (S,G)    spt    to_C3      1
170.0.100.33          10.20.1.6
225.1.1.3              (S,G)    spt    to_C2      1
170.0.100.33          10.20.1.6
225.1.1.4              (S,G)    spt    to_C1      1
170.0.100.33          10.20.1.6
225.1.1.5              (S,G)    spt    to_C0      1
170.0.100.33          10.20.1.6
225.1.1.6              (S,G)    spt    to_C3      1
170.0.100.33          10.20.1.6

225.2.1.1              (S,G)    spt    to_C0      1
170.0.100.33          10.20.1.6
225.2.1.2              (S,G)    spt    to_C3      1
170.0.100.33          10.20.1.6
225.2.1.3              (S,G)    spt    to_C2      1
170.0.100.33          10.20.1.6
225.2.1.4              (S,G)    spt    to_C1      1
170.0.100.33          10.20.1.6
225.2.1.5              (S,G)    spt    to_C0      1
170.0.100.33          10.20.1.6
225.2.1.6              (S,G)    spt    to_C3      1
170.0.100.33          10.20.1.6

225.3.1.1              (S,G)    spt    to_C0      1
170.0.100.33          10.20.1.6
225.3.1.2              (S,G)    spt    to_C3      1
170.0.100.33          10.20.1.6

```

Core Router Multicast Requirements

225.3.1.3	(S,G)	spt	to_C2	1
170.0.100.33		10.20.1.6		
225.3.1.4	(S,G)	spt	to_C1	1
170.0.100.33		10.20.1.6		
225.3.1.5	(S,G)	spt	to_C0	1
170.0.100.33		10.20.1.6		
225.3.1.6	(S,G)	spt	to_C3	1
170.0.100.33		10.20.1.6		
225.4.1.1	(S,G)	spt	to_C0	1
170.0.100.33		10.20.1.6		
225.4.1.2	(S,G)	spt	to_C3	1
170.0.100.33		10.20.1.6		
225.4.1.3	(S,G)	spt	to_C2	1
170.0.100.33		10.20.1.6		
225.4.1.4	(S,G)	spt	to_C1	1
170.0.100.33		10.20.1.6		
225.4.1.5	(S,G)	spt	to_C0	1
170.0.100.33		10.20.1.6		
225.4.1.6	(S,G)	spt	to_C3	1
170.0.100.33		10.20.1.6		

Groups : 24

LAG Interworking

LAG may be used on the second mile (from a DSLAM to a 7750) or on trunk networks.

The CAC policy, which is applied on an interface or VPLS SAP/SDP level, may have to be re-evaluated when one of the component links fails (i.e. in the case that BTV multipoint traffic would in normal mode be hashed across the component links).

- The CAC policy allows specifying the amount of component links used for BTV distribution in normal operation as well as the available BTV bandwidth in normal mode of operation on an interface and bundle level.
- The CAC constraints to be applied in degraded mode can be explicitly configured for the interface/bundle. There are multiple constraint-levels defined that can be selected depending on the severity of the failure.

The set of CAC constraints to be used is automatically determined based on the remaining number of operational links. The operation links determine the weight level for the LAG group. The CAC constraints definition specify the weight level to which they apply.

For a LAG of three or more component links (where three CAC constraint levels could be applied), the CAC constraints in the policy could look like:

Table 6: LAG/CAC Constraints

	Allowed Bandwidth in Mbps (normal mode)	Allowed Bandwidth in Mbps (degraded mode 1)	Allowed Bandwidth in Mbps (degraded mode 2)
Weight (tbc)	>=10	>=6	>=2
Interface	750	400	200
Bundle 1	580	300	200
Bundle 2	634	350	250
...

In the case of reduction of available bandwidth (for example, a component link failure), CAC attempts to fit all mandatory channels. This is performed by re-evaluating the mandatory channels in an arbitrary order using the same two-level CAC algorithm applied at the interface and bundle levels, and using the constraints for the degraded mode of operation. If there is not sufficient capacity to carry all mandatory channels in this degraded mode, some are channels will be dropped. If capacity for BTV is remaining, then subsequently all optional channels are re-evaluated in an arbitrary order. Distribution of some of them may be stopped as a consequence.

Core Router Multicast Requirements

When a previously failed link becomes re-operational then the CAC algorithm takes into account the return to the normally configured bandwidth, and as a result, starts accepting more optional channels again.

CAC Policy for Split Horizon Groups

When IGMP snooping on residential SAPs was introduced enabling multicast CAC policies to be applied to split horizon groups. When a CAC policies are applied to a split horizon group then member SAPs do not permit policy enforcement configurations.

Dynamic Multicast Signaling over P2MP LDP

This feature provides a flexible multicast signaling solution to connect native IP multicast source and receivers that are running PIM multicast protocol via an intermediate MPLS (P2MP LDP LSP) network. It allows each native IP multicast flow to be connected via an intermediate P2MP LSP by dynamically mapping each PIM multicast flow to a P2MP LDP LSP.

It is not required to manually configure a mapping of (S,G) to a P2MP LSP on the edge node of MPLS network. A signaling method is defined that allows dynamic mapping of PIM signaling to P2MP LDP tree setup on the leaf node of P2MP LSP and also P2MP LDP signaling to be handed back to PIM on root node of P2MP LSP. Due to dynamic mapping of multicast IP flow to P2MP LSP, provisioning and maintenance overhead is eliminated as multicast distribution services are added and removed from the network.

P2MP LDP LSP signaling is initiated from node that receives PIM JOIN from a downstream node. **p2mp-ldp-tree-join** must be configured on PIM outgoing interface that received PIM JOIN to enable handover of multicast tree signaling from PIM to P2MP LDP LSP.

Leaf node of P2MP LDP LSP selects the upstream-hop as the root node of LDP FEC based on route table lookup. On the root node of P2MP LDP LSP, multicast tree signaling is handed back to PIM and propagated upstream as native-IP PIM JOIN.

Only PIM-SSM is supported with this feature. A single instance of P2MP LDP LSP is supported between the root and leaf nodes per multicast flow, that is, no stitching of dynamic trees.

If multiple criteria exist to setup a multicast flow then following priority is given:

1. Multicast (statically provisioned) over P2MP LSP (RSVP-TE or LDP)
2. Dynamic multicast signaling over P2MP LDP
3. PIM native-IP multicast

Multicast Configuration Process Overview

Figure 2 displays the process to configure multicast parameters.

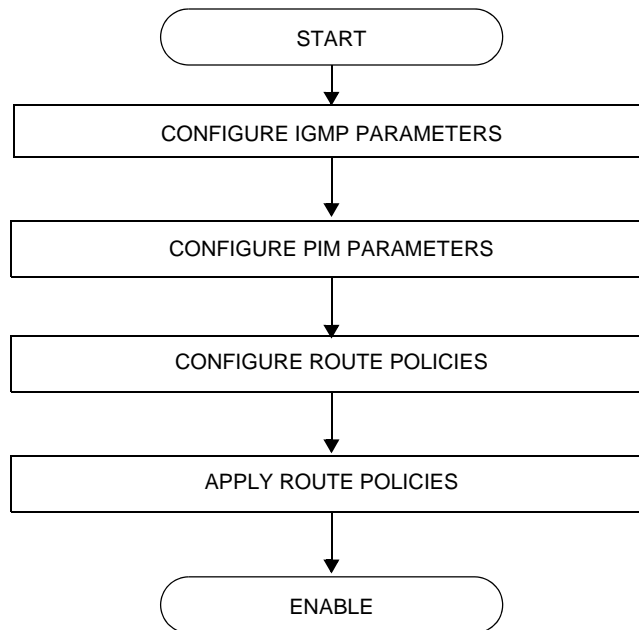

Figure 2: IP Router Configuration Flow

Configuration Notes

This section describes multicast configuration caveats.

General

- A multicast stream is required by one or more multicast clients.
- A multicast stream is offered by one or more multicast servers.

Configuring Multicast Parameters with CLI

This section provides information to configure multicast, IGMP, and PIM.

Topics in this section include:

- [Multicast Configuration Overview on page 66](#)
- [Basic Configuration on page 67](#)
- [Common Configuration Tasks on page 70](#)
- [Service Management Tasks on page 87](#)

Multicast Configuration Overview

7750 SR routers use IGMP to manage membership for a given multicast session. IGMP is not enabled by default. When enabled, at least one interface must be specified in the IGMP context as IGMP is an interface function. Creating an interface enables IGMP. Traffic can only flow away from the router to an IGMP interface and to and from a PIM interface. A router directly connected to a source must have PIM enabled on the interface to that source. The traffic travels in a network from PIM interface to PIM interface and arrives finally on an IGMP enabled interface.

The IGMP CLI context allows you to specify an existing IP interface and modify the interface-specific parameters. Static IGMP group memberships can be configured to test multicast forwarding without a receiver host. When IGMP static group membership is enabled, data is forwarded to an interface without receiving membership reports from host members.

When static IGMP group entries on point-to-point links that connect routers to a rendezvous point (RP) are configured, the static IGMP group entries do not generate join messages toward the RP. When a host wants to receive multicast sessions it sends a join message for each multicast group it wants to join. Then, a leave message may be sent for each multicast group it no longer wishes to participate with.

A multicast router keeps a list of multicast group memberships for each attached network, and an interval timer for each membership. Hosts issue a Multicast Group Membership Report when they want to receive a multicast session. The reports are sent to all multicast routers.

PIM is not enabled by default. When PIM is enabled, data is forwarded to network segments with active receivers that have explicitly requested the multicast group. When enabled, at least one interface must be specified in the PIM context as PIM is an interface function. Creating an interface enables PIM.

Basic Configuration

Perform the following basic multicast configuration tasks:

For IGMP:

- Enable IGMP (required)
- Configure IGMP interfaces (required)
- Specify IGMP version on the interface (optional)
- Configure static (S,G)/(*,G) (optional)
- Configure SSM translation (optional)

For PIM:

- Enable PIM (required)
- Add interfaces so the protocol establishes adjacencies with the neighboring routers (required)
- Configure a way to calculate group-to-RP mapping (required) by either:
 - Static group-to-RP mapping
 - Enable Candidate RP/Bootstrap mechanism on some routers.
- Enable unicast routing protocols to learn routes towards the RP/source for reverse path forwarding (required)
- Add SSM ranges (optional)
- Enable Candidate BSR (optional)
- Enable Candidate RP (optional)
- Change hello interval (optional)
- Configure route policies (bootstrap-export, bootstrap-import, import join and register)

For MSDP:

- Enable MSDP (required)
- Configure peer
- Configure local address

For MCAC:

- Configure policy name
- Configure bundle parameters
- Specify default action

The following example displays the enabled IGMP and PIM configurations:

```
A:LAX>config>router>igmp# info
-----
interface "lax-vls"
  exit
interface "pl-ix"
  exit
-----
A:LAX>config>router>igmp# info detail
-----
interface "lax-vls"
  no import
  version 3
  no shutdown
exit
interface "pl-ix"
  no import
  version 3
  no shutdown
exit
query-interval 125
query-last-member-interval 1
query-response-interval 10
robust-count 2
no shutdown
-----
A:LAX>config>router>igmp# exit
A:LAX>config>router# pim
A:LAX>config>router>pim# info
-----
interface "system"
  exit
interface "lax-vls"
  exit
interface "lax-sjc"
  exit
interface "pl-ix"
  exit
rp
  static
    address 2.22.187.237
    group-prefix 224.24.24.24/32
  exit
  bsr-candidate
    shutdown
  exit
  rp-candidate
    shutdown
  exit
exit
-----
A:LAX>config>router>pim# info detail
-----
no import join-policy
no import register-policy
interface "system"
```

```

    priority 1
    hello-interval 30
    multicast-senders auto
    no tracking-support
    bsm-check-rtr-alert
    no shutdown
exit
interface "lax-vls"
    priority 1
    hello-interval 30
    multicast-senders auto
    no tracking-support
    bsm-check-rtr-alert
    no shutdown
exit
interface "lax-sjc"
    priority 1
    hello-interval 30
    multicast-senders auto
    no tracking-support
    bsm-check-rtr-alert
    no shutdown
exit
interface "pl-ix"
    priority 1
    hello-interval 30
    multicast-senders auto
    no tracking-support
    bsm-check-rtr-alert
    no shutdown
exit
apply-to none
rp
    no bootstrap-import
    no bootstrap-export
    static
        address 2.22.187.237
            no override
            group-prefix 224.24.24.24/32
    exit
exit
bsr-candidate
    shutdown
    priority 0
    hash-mask-len 30
    no address
exit
rp-candidate
    shutdown
    no address
    holdtime 150
    priority 192
exit
exit
no shutdown

```

```
-----
A:LAX>config>router>pim#
```

Common Configuration Tasks

The following sections describe basic multicast configuration tasks.

- [Configuring IGMP Parameters on page 70](#)
 - [Enabling IGMP on page 70](#)
 - [Configuring an IGMP Interface on page 71](#)
 - [Configuring Static Parameters on page 72](#)
 - [Configuring SSM Translation on page 74](#)
- [Configuring PIM Parameters on page 75](#)
 - [Enabling PIM on page 75](#)
 - [Configuring PIM Interface Parameters on page 76](#)
 - [Importing PIM Join/Register Policies on page 81](#)
- [Configuring Multicast Source Discovery Protocol \(MSDP\) Parameters on page 83](#)
- [Configuring MCAC Parameters on page 84](#)
- [Disabling IGMP or PIM on page 87](#)

Configuring IGMP Parameters

Enabling IGMP

Use the following CLI syntax to enable IGMP.

CLI Syntax: `config>router# igmp`

The following example displays the detailed output when IGMP is enabled.

```
A:LAX>>config>router# info detail
...
#-----
echo "IGMP Configuration"
#-----
      igmp
        query-interval 125
        query-last-member-interval 1
        query-response-interval 10
        robust-count 2
        no shutdown
      exit
#-----
A:LAX>>config>system#
```

Configuring an IGMP Interface

To configure an IGMP interface:

CLI Syntax: config>router# igmp
 interface *ip-int-name*
 max-groups *value*
 import *policy-name*
 version *version*
 no shutdown

Use the following CLI syntax to configure IGMP interfaces:

Example: config>router#
 config>router>igmp# interface "lax-vls"
 config>router>igmp>if? no shutdown
 config>router>igmp>if# exit
 config>router>igmp# interface "pl-ix"
 config>router>igmp>if? no shutdown
 config>router>igmp>if# exit
 config>router>igmp# interface "lax-sjc"
 config>router>igmp>if? no shutdown
 config>router>igmp>if# exit

The following example displays the IGMP configuration:

```
A:LAX>config>router>igmp# info
-----
      interface "lax-sjc"
      exit
      interface "lax-vls"
      exit
      interface "pl-ix"
      exit
-----
A:LAX>config>router>igmp# exit
```

Configuring Static Parameters

To add an IGMP static multicast source:

CLI Syntax: config>router# igmp
 interface *ip-int-name*
 no shutdown
 static
 group *grp-ip-address*
 source *ip-address*

Use the following CLI syntax to configure static group addresses and source addresses for the SSM translate group ranges:

Example: config>router>igmp# interface lax-vls
config>router>igmp>if# static
config>router>igmp>if>static# group 229.255.0.2
config>router>igmp>if>static>group# source 172.22.184.197
config>router>igmp>if>static>group# exit
config>router>igmp>if>static# exit
config>router>igmp>if# exit

The following example displays the configuration:

```
A:LAX>config>router>igmp# info
-----
interface "lax-sjc"
exit
interface "lax-vls"
static
group 229.255.0.2
source 172.22.184.197
exit
exit
exit
interface "pl-ix"
exit
-----
A:LAX>config>router>igmp#
```

To add an IGMP static starg entry:

CLI Syntax: config>router# igmp
 interface *ip-int-name*
 no shutdown
 static
 group *grp-ip-address*
 starg

Use the following CLI syntax to configure static group addresses and add a static (*,G) entry:

Example: config>router>igmp# interface lax-sjc
 config>router>igmp>if# static
 config>router>igmp>if>static# group 230.1.1.1
 config>router>igmp>if>static>group# starg
 config>router>igmp>if>static>group# exit
 config>router>igmp>if>static# exit
 config>router>igmp>if# exit
 config>router>igmp#

The following example displays the configuration:

```
A:LAX>config>router>igmp# info
-----
interface "lax-sjc"
  static
    group 230.1.1.1
    starg
  exit
exit
interface "lax-vls"
  static
    group 229.255.0.2
    source 172.22.184.197
  exit
exit
interface "pl-ix"
exit
-----
A:LAX>config>router>igmp#
```

Configuring SSM Translation

To configure IGMP parameters:

CLI Syntax: config>router# igmp
 ssm-translate
 grp-range *start end*
 source *ip-address*

The following example displays the command usage to configure IGMP parameters:

Example: config>router# igmp
 config>router>igmp# ssm-translate
 config>router>igmp>ssm# grp-range 229.255.0.1 231.2.2.2
 config>router>igmp>ssm>grp-range# source 10.1.1.1

The following example displays the SSM translation configuration:

```
A:LAX>config>router>igmp# info
-----
      ssm-translate
      grp-range 229.255.0.1 231.2.2.2
      source 10.1.1.1
      exit
    exit
  interface "lax-sjc"
    static
      group 230.1.1.1
      starg
    exit
  exit
  interface "lax-vls"
    static
      group 229.255.0.2
      source 172.22.184.197
    exit
  exit
  interface "pl-ix"
  exit
-----
A:LAX>config>router>igmp# exit
```

Configuring PIM Parameters

- [Enabling PIM on page 75](#)
- [Configuring PIM Interface Parameters on page 76](#)
- [Importing PIM Join/Register Policies on page 81](#)

Enabling PIM

When configuring PIM, make sure to enable PIM on all interfaces for the routing instance, otherwise multicast routing errors can occur.

Use the following CLI syntax to enable PIM.

CLI Syntax: config>router# pim

The following example displays the detailed output when PIM is enabled.

```
A:LAX>>config>router# info detail
...
#-----
echo "PIM Configuration"
#-----
    pim
        no import join-policy
        no import register-policy
        apply-to none
        rp
            no bootstrap-import
            no bootstrap-export
            static
            exit
            bsr-candidate
                shutdown
                priority 0
                hash-mask-len 30
                no address
            exit
            rp-candidate
                shutdown
                no address
                holdtime 150
                priority 192
            exit
        exit
    no shutdown
    exit
#-----
...
A:LAX>>config>system#
```

Configuring PIM Interface Parameters

The following example displays the command usage to configure PIM interface parameters:

```
Example:A:LAX>config>router# pim
A:LAX>>config>router>pim# interface "system"
A:LAX>>config>router>pim>if# exit
A:LAX>>config>router>pim# interface "lax-vls"
A:LAX>>config>router>pim>if# exit
A:LAX>>config>router>pim# interface "lax-sjc"
A:LAX>>config>router>pim>if# exit
A:LAX>>config>router>pim# interface "p1-ix"
A:LAX>>config>router>pim>if# exit
A:LAX>>config>router>pim# rp
A:LAX>>config>router>pim>rp# static
A:LAX>>config>router>pim>rp>static# address 2.22.187.237
A:LAX>>config>router>..>address# group-prefix 224.24.24.24/32
A:LAX>>config>router>pim>rp>static>address# exit
A:LAX>>config>router>pim>rp>static# exit
A:LAX>>config>router>pim>rp# exit
A:LAX>>config>router>pim#
```

The following example displays the PIM configuration:

```
A:LAX>>config>router>pim# info
-----
interface "system"
exit
interface "lax-vls"
exit
interface "lax-sjc"
exit
interface "p1-ix"
exit
rp
  static
    address 2.22.187.237
    group-prefix 224.24.24.24/32
    exit
    address 10.10.10.10
    exit
  exit
  bsr-candidate
  shutdown
  exit
  rp-candidate
  shutdown
  exit
exit
-----
A:LAX>>config>router>pim#
```

```

Example:A:SJC>config>router# pim
A:SJC>config>router>pim# interface "system"
A:SJC>config>router>pim>if# exit
A:SJC>config>router>pim# interface "sjc-lax"
A:SJC>config>router>pim>if# exit
A:SJC>config>router>pim# interface "sjc-nyc"
A:SJC>config>router>pim>if# exit
A:SJC>config>router>pim# interface "sjc-sfo"
A:SJC>config>router>pim>if# exit
A:SJC>config>router>pim# rp
A:SJC>config>router>pim>rp# static
A:SJC>config>router>pim>rp>static# address 2.22.187.237
A:SJC>config>router>pim>rp>static>address# group-prefix
224.24.24.24/32
A:SJC>config>router>pim>rp>static>address# exit
A:SJC>config>router>pim>rp>static# exit
A:SJC>config>router>pim>rp# exit
A:SJC>config>router>pim#

```

```

A:SJC>config>router>pim# info
-----
interface "system"
exit
interface "sjc-lax"
exit
interface "sjc-nyc"
exit
interface "sjc-sfo"
exit
rp
  static
    address 2.22.187.237
    group-prefix 224.24.24.24/32
    exit
  exit
  bsr-candidate
    shutdown
  exit
  rp-candidate
    shutdown
  exit
  exit
-----
A:SJC>config>router>pim#

```

Common Configuration Tasks

```
Example:A:MV>config>router# pim
A:MV>config>router>pim# interface "system"
A:MV>config>router>pim>if# exit
A:MV>config>router>pim# interface "mv-sfo"
A:MV>config>router>pim>if# exit
A:MV>config>router>pim# interface "mv-vlc"
A:MV>config>router>pim>if# exit
A:MV>config>router>pim# interface "p3-ix"
A:MV>config>router>pim>if# exit
A:MV>config>router>pim# rp
A:MV>config>router>pim>rp# static
A:MV>config>router>pim>rp>static# address 2.22.187.237
A:MV>config>router>pim>rp>static>address# group-prefix
224.24.24.24/32
A:MV>config>router>pim>rp>static>address# exit
A:MV>config>router>pim>rp>static#
A:MV>config>router>pim>rp# exit
A:MV>config>router>pim#
```

```
A:MV>config>router>pim# info
-----
      interface "system"
      exit
      interface "mv-sfo"
      exit
      interface "mv-vlc"
      exit
      interface "p3-ix"
      exit
      rp
        static
          address 2.22.187.237
          group-prefix 224.24.24.24/32
          exit
        exit
        bsr-candidate
          address 2.22.187.236
          no shutdown
        exit
        rp-candidate
          address 2.22.187.236
          no shutdown
        exit
      exit
-----
A:MV>config>router>pim#
```

```

Example:A:SFO>config>router# pim
A:SFO>config>router>pim# interface "system"
A:SFO>config>router>pim>if# exit
A:SFO>config>router>pim# interface "sfo-sfc"
A:SFO>config>router>pim>if# exit
A:SFO>config>router>pim# interface "sfo-was"
A:SFO>config>router>pim>if# exit
A:SFO>config>router>pim# interface "sfo-mv"
A:SFO>config>router>pim>if# exit
A:SFO>config>router>pim# rp
A:SFO>config>router>pim>rp# static
A:SFO>config>router>pim>rp>static# address 2.22.187.237
A:SFO>config>router>pim>rp>static>address# group-prefix
224.24.24.24/32
A:SFO>config>router>pim>rp>static>address# exit
A:SFO>config>router>pim>rp>static# exit
A:SFO>config>router>pim>rp # exit
A:SFO>config>router>pim#

```

```

A:SFO>config>router>pim# info
-----
      interface "system"
      exit
      interface "sfo-sjc"
      exit
      interface "sfo-was"
      exit
      interface "sfo-mv"
      exit
      rp
      static
      address 2.22.187.237
      group-prefix 224.24.24.24/32
      exit
      exit
      bsr-candidate
      address 2.22.187.239
      no shutdown
      exit
      rp-candidate
      address 2.22.187.239
      no shutdown
      exit
      exit
-----
A:SFO>config>router>pim#

```

Common Configuration Tasks

```
Example:A:WAS>config>router# pim
A:WAS>config>router>pim# interface "system"
A:WAS>config>router>pim>if# exit
A:WAS>config>router>pim# interface "was-sfo"
A:WAS>config>router>pim>if# exit
A:WAS>config>router>pim# interface "was-vlc"
A:WAS>config>router>pim>if# exit
A:WAS>config>router>pim# interface "p4-ix"
A:WAS>config>router>pim>if# exit
A:WAS>config>router>pim# rp
A:WAS>config>router>pim>rp# static
A:WAS>config>router>pim>rp>static# address 2.22.187.237
A:WAS>config>router>pim>rp>static>address# group-prefix
224.24.24.24/32
A:WAS>config>router>pim>rp>static>address# exit
A:WAS>config>router>pim>rp>static# exit
A:WAS>config>router>pim>rp# bsr-candidate
A:WAS>config>router>pim>rp>bsr-cand# address 2.22.187.240
A:WAS>config>router>pim>rp>bsr-cand# no shutdown
A:WAS>config>router>pim>rp>bsr-cand# exit
A:WAS>config>router>pim>rp# exit
A:WAS>config>router>pim#
```

```
A:WAS>config>router>pim# info
-----
      interface "system"
      exit
      interface "was-sfo"
      exit
      interface "was-vlc"
      exit
      interface "p4-ix"
      exit
      rp
        static
          address 2.22.187.237
          group-prefix 224.24.24.24/32
          exit
        exit
      bsr-candidate
        address 2.22.187.240
        no shutdown
      exit
      rp-candidate
        address 2.22.187.240
        no shutdown
      exit
    exit
-----
A:WAS>config>router>pim#
```

Importing PIM Join/Register Policies

The import command provides a mechanism to control the (*,G) and (S,G) state that gets created on a router. Import policies are defined in the **config>router>policy-options** context.

Note, in the import policy, if an action is not specified in the entry then the default-action takes precedence. If no entry matches then the default-action also takes precedence. If no default-action is specified, then the default default-action is executed.

Use the following commands to configure PIM parameters:

CLI Syntax:

```
config>router# pim
import {join-policy|register-policy} [policy-name]
[..policy-name]
```

The following example displays the command usage to apply the policy statement which does not allow join messages for group 229.50.50.208/32 and source 192.168.0.0/16 but allows join messages for 192.168.0.0/16, 229.50.50.208 (see [Configuring Route Policy Components on page 758](#)):

Example:

```
config>router# pim
config>router>pim# import join-policy "foo"
config>router>pim# no shutdown
```

The following example displays the PIM configuration:

```
A:LAX>config>router>pim# info
-----
import join-policy "foo"
interface "system"
exit
interface "lax-vls"
exit
interface "lax-sjc"
exit
interface "pl-ix"
exit
rp
static
address 2.22.187.237
group-prefix 224.24.24.24/3
exit
address 10.10.10.10
exit
exit
bsr-candidate
shutdown
```

Common Configuration Tasks

```
        exit
        rp-candidate
            shutdown
        exit
    exit
-----
A:LAX>config>router>pim#
```

Configuring Multicast Source Discovery Protocol (MSDP) Parameters

Use the following commands to configure basic MSDP parameters:

CLI Syntax:

```
config>router# msdp
  peer ip-address
    active-source-limit number
    authentication-key [authentication-key|hash-key]
    [hash|hash2]
    default-peer
    export policy-name [policy-name...(up to 5 max)]
    import policy-name [policy-name...(up to 5 max)]
    local-address ip-address
    receive-msdp-msg-rate number intervalseconds [threshold
    threshold]
    no shutdown
no shutdown
```

Use the following CLI syntax to configure MSDP parameters.

Example:

```
config>router>msdp# peer 10.20.1.1
config>router>msdp>peer# local-address 10.20.1.6
config>router>msdp>peer# no shutdown
config>router>msdp>peer# exit
config>router>msdp# no shutdown
config>router>msdp#
```

The following example displays the MSDP configuration:

```
ALA-48>config>router>msdp# info
-----
    peer 10.20.1.1
      local-address 10.20.1.6
    exit
-----
ALA-48>config>router>msdp#
```

Configuring MCAC Parameters

The MCAC policies can be added to a SAP, spoke SDP, mesh SDP, an IGMP interface, and a PIM interface.

The following example displays the command usage to create MCAC policies.

```

Example: config>router# mcac
config>router>mcac# policy "btv_fr"
config>router>mcac>policy# description "foreign TV offering"
config>router>mcac>policy# bundle "FOR" create
config>router>mcac>policy>bundle# bandwidth 30000
config>router>mcac>policy>bundle# channel 224.0.3.1 224.0.3.1 bw 4000
config>router>mcac>policy>bundle# channel 224.0.3.2 224.0.3.2 bw 4000
config>router>mcac>policy>bundle# channel 224.0.4.1 224.0.4.1 bw 3500 class high type mandatory
config>router>mcac>policy>bundle# channel 224.0.4.2 224.0.4.2 bw 3500 class high
config>router>mcac>policy>bundle# channel 224.0.4.3 224.0.4.3 bw 2800 type mandatory
config>router>mcac>policy>bundle# channel 224.0.4.4 224.0.4.4 bw 2800
config>router>mcac>policy>bundle# mc-constraints
config>router>mcac>policy>bundle>mc-constraints# level 1 bw 20000
config>router>mcac>policy>bundle>mc-constraints# level 2 bw 20000
config>router>mcac>policy>bundle>mc-constraints# level 3 bw 20000
config>router>mcac>policy>bundle>mc-constraints# level 4 bw 20000
config>router>mcac>policy>bundle>mc-constraints# level 5 bw 20000
config>router>mcac>policy>bundle>mc-constraints# level 6 bw 20000 config>router>mcac>policy>bundle>mc-constraints# lag-port-down 1 number-down 1 level 1
config>router>mcac>policy>bundle>mc-constraints# lag-port-down 1 number-down 2 level 3
config>router>mcac>policy>bundle>mc-constraints# lag-port-down 1 number-down 3 level 5
config>router>mcac>policy>bundle>mc-constraints# lag-port-down 2 number-down 1 level 1
config>router>mcac>policy>bundle>mc-constraints# lag-port-down 2 number-down 2 level 3
config>router>mcac>policy>bundle>mc-constraints# lag-port-down 2 number-down 3 level 5
config>router>mcac>policy>bundle>mc-constraints# exit
config>router>mcac>policy>bundle# no shutdown
config>router>mcac>policy>bundle# exit
config>router>mcac>policy# exit
config>router>mcac# policy "btv_vl"
config>router>mcac>policy# description "eastern TV offering"
config>router>mcac>policy# bundle "VRT" create
config>router>mcac>policy>bundle# bandwidth 120000
config>router>mcac>policy>bundle# channel 224.1.2.0 224.1.2.4 bw 4000class high type mandatory
config>router>mcac>policy>bundle# channel 224.1.2.5 224.1.2.5 bw 20000 type mandatory
config>router>mcac>policy>bundle# channel 224.1.2.10 224.1.2.10 bw 8000 type mandatory
config>router>mcac>policy>bundle# channel 224.2.2.0 224.2.2.4 bw 4000
config>router>mcac>policy>bundle# channel 224.2.2.5 224.2.2.5 bw 10000 class high
config>router>mcac>policy>bundle# channel 224.2.2.6 224.2.2.6 bw 10000 class high
config>router>mcac>policy>bundle# channel 224.2.2.7 224.2.2.7 bw 10000
config>router>mcac>policy>bundle# channel 224.2.2.8 224.2.2.8 bw 10000
config>router>mcac>policy>bundle# mc-constraints
config>router>mcac>policy>bundle>mc-constraints# level 1 bw 60000
config>router>mcac>policy>bundle>mc-constraints# level 2 bw 50000
config>router>mcac>policy>bundle>mc-constraints# level 3 bw 40000
config>router>mcac>policy>bundle>mc-constraints# level 4 bw 30000
config>router>mcac>policy>bundle>mc-constraints# level 5 bw 20000
config>router>mcac>policy>bundle>mc-constraints# level 6 bw 10000

```

```

config>router>mcac>policy>bundle>mc-constraints# lag-port-down 1 number-down 1 level 1
config>router>mcac>policy>bundle>mc-constraints# lag-port-down 1 number-down 2 level 3
config>router>mcac>policy>bundle>mc-constraints# lag-port-down 1 number-down 3 level 5
config>router>mcac>policy>bundle>mc-constraints# lag-port-down 2 number-down 1 level 1
config>router>mcac>policy>bundle>mc-constraints# lag-port-down 2 number-down 2 level 3
config>router>mcac>policy>bundle>mc-constraints# lag-port-down 2 number-down 3 level 5
config>router>mcac>policy>bundle>mc-constraints# exit
config>router>mcac>policy>bundle# no shutdown
config>router>mcac>policy>bundle# exit
config>router>mcac>policy# exit

```

The following example displays the configuration:

```

*A:ALA-48>config>router>mcac# info
-----
policy "btv_fr"
  description "foreign TV offering"
  bundle "FOR" create
    bandwidth 30000
    channel 224.0.3.1 224.0.3.1 bw 4000
    channel 224.0.3.2 224.0.3.2 bw 4000
    channel 224.0.4.1 224.0.4.1 bw 3500 class high type mandatory
    channel 224.0.4.2 224.0.4.2 bw 3500 class high
    channel 224.0.4.3 224.0.4.3 bw 2800 type mandatory
    channel 224.0.4.4 224.0.4.4 bw 2800
  mc-constraints
    level 1 bw 20000
    level 2 bw 20000
    level 3 bw 20000
    level 4 bw 20000
    level 5 bw 20000
    level 6 bw 20000
    lag-port-down 1 number-down 1 level 1
    lag-port-down 1 number-down 2 level 3
    lag-port-down 1 number-down 3 level 5
    lag-port-down 2 number-down 1 level 1
    lag-port-down 2 number-down 2 level 3
    lag-port-down 2 number-down 3 level 5
  exit
  no shutdown
exit
exit
policy "btv_vl"
  description "eastern TV offering"
  bundle "VRT" create
    bandwidth 120000
    channel 224.1.2.0 224.1.2.4 bw 4000 class high type mandatory
    channel 224.1.2.5 224.1.2.5 bw 20000 type mandatory
    channel 224.1.2.10 224.1.2.10 bw 8000 type mandatory
    channel 224.2.2.0 224.2.2.4 bw 4000
    channel 224.2.2.5 224.2.2.5 bw 10000 class high
    channel 224.2.2.6 224.2.2.6 bw 10000 class high
    channel 224.2.2.7 224.2.2.7 bw 10000
    channel 224.2.2.8 224.2.2.8 bw 10000
  mc-constraints
    level 1 bw 60000
    level 2 bw 50000

```

Common Configuration Tasks

```
level 3 bw 40000
level 4 bw 30000
level 5 bw 20000
level 6 bw 10000
lag-port-down 1 number-down 1 level 1
lag-port-down 1 number-down 2 level 3
lag-port-down 1 number-down 3 level 5
lag-port-down 2 number-down 1 level 1
lag-port-down 2 number-down 2 level 3
lag-port-down 2 number-down 3 level 5
exit
no shutdown
exit
exit
-----
*A:ALA-48>config>router>mcac#
```

Service Management Tasks

This section discusses the following service management tasks:

- [Disabling IGMP or PIM on page 87](#)
-

Disabling IGMP or PIM

Use the following CLI syntax to disable IGMP and PIM:

CLI Syntax:

```
config>router#
  igmp
    shutdown
  msdp
    shutdown
  pim
    shutdown
```

The following example displays the command usage to disable multicast:

Example:

```
config>router# igmp
config>router>igmp# shutdown
config>router>igmp# exit
config>router#
config>router>msdp# shutdown
config>router>msdp# exit
config>router# pim
config>router>pim# shutdown
config>router>pim# exit
```

Service Management Tasks

The following example displays the configuration output:

```
A:LAX>config>router# info
-----
...
#-----
echo "IGMP Configuration"
#-----
    igmp
      shutdown
      ssm-translate
        grp-range 229.255.0.1 231.2.2.2
        source 10.1.1.1
      exit
    exit
    interface "lax-sjc"
      static
        group 230.1.1.1
        starg
      exit
    exit
    interface "lax-vls"
      static
        group 229.255.0.2
        source 172.22.184.197
      exit
    exit
    interface "pl-ix"
    exit
  exit
#-----

#-----
echo "MSDP Configuration"
#-----
    msdp
      shutdown
      peer 10.20.1.1
        local-address 10.20.1.6
      exit
      group "test"
        active-source-limit 50000
        receive-msdp-msg-rate 100 interval 300 threshold 5000
        export "LDP-export"
        import "LDP-import"
        local-address 10.10.10.103
        mode mesh-group
        peer 10.10.10.104
      exit
    exit
  exit
#-----

echo "PIM Configuration"
#-----
    pim
```



```
shutdown
import join-policy "foo"
interface "system"
exit
interface "lax-sjc"
exit
interface "lax-vls"
exit
interface "pl-ix"
exit
rp
  static
    address 2.22.187.237
      group-prefix 224.24.24.24/32
    exit
    address 10.10.10.10
    exit
  exit
  bsr-candidate
    shutdown
  exit
  rp-candidate
    shutdown
  exit
exit
exit
#-----
....
-----
A:LAX>config>router#
```

Multicast Command Reference

Command Hierarchies

- [Configuration Commands on page 91](#)
 - [IGMP Commands on page 91](#)
 - [PIM Commands on page 93](#)
 - [MSDP Commands on page 96](#)
 - [Multicast CAC Policy Commands on page 98](#)
- [Operational Commands on page 100](#)
- [Show Commands on page 100](#)
- [Clear Commands on page 101](#)
- [Debug Commands on page 103](#)

Configuration Commands

```

config
  — router
    — [no] ip-fast-reroute
    — mc-maximum-routes number [log-only] [threshold threshold]
    — no mc-maximum-routes
    — multicast-info policy-name
    — no multicast-info

```

IGMP Commands

```

config
  — router
    — [no] igmp
      — [no] interface ip-int-name
        — [no] disable-router-alert-check
        — [no] group-interface ip-int-name
          — [no] shutdown
        — import policy-name
        — no import
        — max-groups value
        — no max-groups
        — mcac
          — mc-constraints
            — level level-id bw bandwidth
            — no level level-id
            — number-down number-lag-port-down level level-id
            — no number-down number-lag-port-down
            — [no] shutdown
          — policy mcac-policy-name
          — no policy

```

- **unconstrained-bw** *bandwidth* **mandatory-bw** *mandatory-bw*
- **no unconstrained-bw**
- **[no] shutdown**
- **ssm-translate**
 - **[no] grp-range** *start end*
 - **[no] source** *ip-address*
- **static**
 - **[no] group** *grp-ip-address*
 - **[no] source** *ip-address*
 - **[no] starg**
- **[no] subnet-check**
- **version** *version*
- **no version**
- **query-interval** *seconds*
- **no query-interval**
- **query-last-member-interval** *seconds*
- **no query-last-member-interval**
- **query-response-interval** *seconds*
- **no query-response-interval**
- **robust-count** *robust-count*
- **no robust-count**
- **[no] shutdown**
- **ssm-translate**
 - **[no] grp-range** *start end*
 - **[no] source** *ip-address*
- **[no] tunnel-interface** **rsvp-p2mp** *lsp-name*
 - **static**
 - **[no] group** *grp-ip-address*
 - **[no] source** *ip-address*
 - **[no] starg**

PIM Commands

```

config
  — router
    — [no] pim
      — apply-to {ies | non-ies | all | none}
      — [no] enable-mdt-spt
      — import {join-policy | register-policy} policy-name [.. policy-name]
      — no import {join-policy | register-policy}
      — [no] interface ip-int-name
        — assert-period assert-period
        — no assert-period
        — [no] bfd-enable [ipv4 | ipv6]
        — [no] bsm-check-rtr-alert
        — hello-interval hello-interval
        — no hello-interval
        — hello-multiplier deci-units
        — no hello-multiplier
        — [no] improved-assert
        — [no] ipv4-multicast-disable
        — [no] ipv6-multicast-disable
        — max-groups value
        — no max-groups
        — mcac
          — mc-constraints
            — level level bw bandwidth
            — no level level
            — number-down number-lag-port-down level level-id
            — no number-down number-lag-port-down
            — [no] shutdown
          — policy policy-name
          — no policy
          — unconstrained-bw bandwidth mandatory-bw mandatory-bw
          — no unconstrained-bw
        — multicast-senders {auto | always | never}
        — no multicast-senders
        — no p2mp-ldp-tree-join
        — priority dr-priority
        — no priority
        — [no] shutdown
        — sticky-dr [priority dr-priority]
        — no sticky-dr
        — three-way-hello [compatibility-mode]
        — no three-way-hello
        — [no] tracking-support
      — [no] ipv4-multicast-disable
      — ipv6-multicast-disable
      — [no] lag-usage-optimization
      — [no] mc-ecmp-balance
      — mc-ecmp-balance-hold minutes
      — no mc-ecmp-balance-hold
      — [no] mc-ecmp-hashing-enabled
      — [no] non-dr-attract-traffic
      — rp
        — [no] anycast rp-ip-address

```

- [no] **rp-set-peer** *ip-address*
- [no] **auto-rp-discovery**
- **bootstrap-export** *policy-name* [*.. policy-name*]
- **no bootstrap-export**
- **bootstrap-import** *policy-name* [*.. policy-name*]
- **no bootstrap-import**
- **bsr-candidate**
 - **address** *ip-address*
 - **no address**
 - **hash-mask-len** *hash-mask-length*
 - **no hash-mask-len**
 - **priority** *bootstrap-priority*
 - **no priority**
 - [no] **shutdown**
- **ipv6**
 - [no] **anycast** *rp-ip-address*
 - [no] **rp-set-peer** *ip-address*
 - **bsr-candidate**
 - **address** *ip-address*
 - **no address**
 - **hash-mask-len** *hash-mask-length*
 - **no hash-mask-len**
 - **priority** *bootstrap-priority*
 - **no priority**
 - [no] **shutdown**
 - [no] **embedded-rp**
 - [no] **group-range** *ipv6-address/prefix-length*
 - [no] **shutdown**
 - **rp-candidate**
 - **address** *ip-address*
 - **no address**
 - [no] **group-range** {*grp-ip-address/mask* | *grp-ip-address netmask*}
 - **holdtime** *holdtime*
 - **no holdtime**
 - **priority** *priority*
 - **no priority**
 - [no] **shutdown**
 - **static**
 - [no] **address** *ip-address*
 - [no] **group-prefix** {*grp-ip-address/mask* | *grp-ip-address netmask*}
 - [no] **override**
- **rp-candidate**
 - **address** *ip-address*
 - **no address**
 - [no] **group-range** {*grp-ip-address/mask* | *grp-ip-address netmask*}
 - **holdtime** *holdtime*
 - **no holdtime**
 - **priority** *priority*
 - **no priority**
 - [no] **shutdown**
- **static**
 - [no] **address** *ip-address*

- [no] **group-prefix** {*grp-ip-address/mask* | *grp-ip-address netmask*}
- [no] **override**
- [no] **rpf6-table** {*rtable6-m* | *rtable6-u* | **both**}
- [no] **shutdown**
- **spt-switchover-threshold** {*grp-ip-address/mask* | *grp-ip-address netmask*} *spt-threshold*
- **no spt-switchover-threshold** {*grp-ip-address/mask* | *grp-ip-address netmask*}
- [no] **ssm-groups**
 - [no] **group-range** {*ip-prefix/mask* | *ip-prefix netmask*}
- [no] **tunnel-interface** {**rsvp-p2mp** *lsp-name* | **ldp-p2mp** *p2mp-id*} [**sender** *ip-address*] | **ldp-p2mp** *p2mp-id* **sender** *sender-address* [**root-node**]

MSDP Commands

```

config
  — router
    — [no] msdp
      — [no] active-source-limit number
      — [no] data-encapsulation
      — export [policy-name...(up to 5 max)]
      — no export
      — [no] group group-name
        — [no] active-source-limit number
        — export policy-name [policy-name...(up to 5 max)]
        — no export
        — import policy-name [policy-name...(up to 5 max)]
        — no import
        — local-address address
        — no local-address
        — mode {mesh-group | standard}
        — [no] peer peer-address
          — [no] active-source-limit number
          — authentication-key [authentication-key | hash-key]
            [hash|hash2]
          — no authentication-key
          — [no] default-peer
          — export policy-name [policy-name...(up to 5 max)]
          — no export
          — import policy-name [policy-name...(up to 5 max)]
          — no import
          — local-address address
          — no local-address
          — [no] shutdown
          — receive-msdp-msg-rate number interval seconds [threshold number]
          — no receive-msdp-msg-rate
          — [no] shutdown
        — import policy-name [policy-name...(up to 5 max)]
        — no import
        — local-address address
        — no local-address
      — [no] peer peer-address
        — [no] active-source-limit number
        — authentication-key [authentication-key | hash-key] [hash | hash2]
        — no authentication-key
        — [no] default-peer
        — export policy-name[policy-name...(up to 5 max)]
        — no export
        — import policy-name[policy-name...(up to 5 max)]
        — no import
        — local-address address
        — no local-address
        — receive-msdp-msg-rate number interval seconds [threshold number]
        — no receive-msdp-msg-rate
        — [no] shutdown
      — receive-msdp-msg-rate number interval seconds [threshold number]
      — no receive-msdp-msg-rate
      — rpf6-table {rtable-m | rtable-u | both}

```

- **no rpf6-table**
- **sa-timeout** *seconds*
- **no sa-timeout**
- **[no] shutdown**
- **[no] source** *prefix/mask*
 - **active-source-limit** *number*
 - **no active-source-limit** *number*

Multicast CAC Policy Commands

```

config
  — [no] router
    — mcac
      — [no] policy policy-name
        — [no] bundle bundle-name
          — bandwidth bandwidth
          — no bandwidth
          — channel start-address end-address bw bandwidth [class {high | low}] [type {mandatory | optional}]
          — no channel mc-ip-addr mc-ip-addr
          — description description-string
          — no description
          — mc-constraints
            — lag-port-down lag-id number-down number-lag-port-down level level-id
            — no lag-port-down lag-id number-down number-lag-port-down
            — level level bw bandwidth
            — no level level
          — [no] shutdown
        — default-action {accept | discard}
        — description description-string
        — no description

```

Multicast Listener Discovery (MLD) Commands

```

config
  — [no] router
    — [no] mld
      — [no] interface ip-int-name
        — import policy-name
        — no import
        — max-groups value
        — no max-groups
        — query-interval seconds
        — no query-interval
        — query-last-member-interval seconds
        — no query-last-member-interval
        — query-response-interval seconds
        — no query-response-interval
        — [no] shutdown
        — static
          — [no] group grp-ipv6-address
            — [no] source src-ipv6-address
            — [no] starg
          — version version
          — no version
        — query-interval seconds
        — no query-interval
        — query-last-member-interval seconds
        — no query-last-member-interval
        — query-response-interval seconds
        — no query-response-interval
        — robust-count robust-count
        — no robust-count
        — [no] shutdown
        — ssm-translate
          — [no] grp-range start end
            — [no] source src-ipv6-address

```

Operational Commands

<GLOBAL>

- **mrinfo** *ip-address* [**router** *router-name* | *service*]
- **mstat source** *ip-address* [**group** *grp-ip-address*] [**destination** *dst-ip-address*] [**hop** *hop*] [**router** *router-name* | *service*] [**wait-time** *wait-time*]
- **mtrace source** *ip-address* [**group** *grp-ip-address*][**destination** *dst-ip-address*] [**hop** *hop*] [**router** *router-name* | *service*] [**wait-time** *wait-time*]

Show Commands

- ```
show
 — router
 — igmp
 — group [grp-ip-address]
 — group summary
 — hosts [group grp-address] [detail] [fwd-service service-id] [grp-interface ip-int-name]
 — hosts [host ip-address] [group grp-address] [detail]
 — hosts summary
 — interface [ip-int-name | ip-address] [group] [grp-address] [detail]
 — ssm-translate
 — ssm-translate interface interface-name
 — static [ip-int-name | ip-addr]
 — statistics [ip-int-name | ip-address]
 — statistics host [ip-address]
 — status

show
 — router
 — pim
 — anycast [detail]
 — crp [ip-address]
 — s-pmsi [data-nt-interface-name] [detail]
 — group [grp-ip-address] [source ip-address] [type {starstarrp|starg|sg}] [detail] [family]
 — interface [ip-int-name | mt-int-name | ip-address] [group [grp-ip-address] source ip-address] [type {starstarrp | starg | sg}] [detail] [family]
 — neighbor [ip-address | ip-int-name [address ip-address]] [detail] [family]
 — rp [ip-address]
 — rp-hash grp-ip-address
 — statistics [ip-int-name | mt-int-name | ip-address] [family]
 — status [detail] [family]

show
 — router
 — mld
 — group [grp-ipv6-address]
 — interface [ip-int-name | ip-address] [group] [grp-ipv6-address] [detail]
 — ssm-translate
 — static [ip-int-name | ip-address]
 — statistics [ip-int-name | ipv6-address]
 — status

show
 — router
```

```

— msdp
 — group [group-name] [detail]
 — peer [ip-address] [group group-name] [detail]
 — source [ip-address/mask] [type {configured | dynamic | both}] [detail]
 — source-active [group ip-address | local | originator ip-address | peer ip-address |
source ip-address | {group ip-address source ip-address}] [detail]
 — source-active-rejected [peer-group name] [group ip-address] [source ip-
address] [originator ip-address] [peer ip-address]
 — statistics [peer ip-address]
 — status
— mcac
 — policy [policy-name [bundle bundle-name] [protocol protocol-name] [interface
if-name] [detail]]
 — statistics

show
— router {router-instance}
 — mvpn

show
— router
 — tunnel-table [ip-address [/mask]] [protocol | sd sdp-id]
 — tunnel-table [summary]

```

## Clear Commands

```

clear
— router
 — igmp
 — database [interface ip-int-name|ip-address] group grp-ip-address [source src-ip-
address]
 — database grp-interface interface-name [fwd-service service-id]
 — database [interface ip-int-name|ip-address] group grp-ip-address source src-ip-
address
 — database host [ip-address]
 — database interface ip-int-name|ip-address [group grp-ip-address] [source src-ip-
address]
 — statistics [interface ip-int-name | ip-address]
 — version [interface ip-int-name | ip-address]
 — mld
 — database [interface ip-int-name|ipv6-address] [group ip-address] [source ip-
address]]
 — statistics [ip-int-name|ipv6-address]
 — version [ip-int-name | ip-address]
 — msdp
 — cache [peer ip-address] [group ip-address] [source ip-address] [originrp ip-
address]
 — statistics [peer ip-address]
 — pim
 — database [interface ip-int-name | ip-address | mt-int-name] [group grp-ip-address
[source ip-address]][family]]
 — neighbor [interface ip-int-name | ip-address] [family]
 — s-pmsi [mdSrcAddr] [mdGrpAddr] [vprnSrcAddr vprnGrpAddr]

```

- **statistics** [{**interface** *ip-int-name* | *ip-address* | *mt-int-name*}] {**group** *grp-ip-address* [**source** *ip-address*]} [*family*]
- clear**
  - **service**
    - **id**
      - **igmp-snooping**
        - **port-db** **sap** *sap-id* [**group** *grp-address* [**source** *ip-address*]]
        - **port-db** **sdp** *sdp-id:vc-id* [**group** *grp-address* [**source** *ip-address*]]
        - **querier**
        - **statistics** [**all** | **sap** *sap-id* | **sdp** *sdp-id:vc-id*]
      - **pim-snooping**
        - **database** [[**sap** *sap-id* | **sdp** *sdp-id:vc-id*] [**group** *grp-ip-address*] [**source** *src-ip-address*]]
        - **neighbor** [*ip-address* | **sap** *sap-id* | **sdp** *sdp-id:vc-id*]
        - **statistics** [**sap** *sap-id* | **sdp** *sdp-id:vc-id*]

## Debug Commands

```

debug
 — router
 — igmp
 — [no] group-interface [fwd-service service-id] [ip-int-name]
 — host [ip-address]
 — host [fwd-service service-id] group-interface ip-int-name
 — no host [ip-address]
 — no host [fwd-service service-id] group-interface ip-int-name
 — [no] interface [ip-int-name | ip-address]
 — mcs [ip-int-name]
 — no mcs
 — [no] misc
 — packet [query|v1-report|v2-report|v3-report|v2-leave] host ip-address
 — no packet [query|v1-report|v2-report|v3-report|v2-leave] [ip-int-name|ip-
 address]
 — no packet [query|v1-report|v2-report|v3-report|v2-leave] host ip-address
 — packet [query|v1-report|v2-report|v3-report|v2-leave] [ip-int-name|ip-address]

debug
 — router
 — pim
 — [no] adjacency
 — all [group grp-ip-address] [source ip-address] [detail]
 — no all
 — assert [group grp-ip-address] [source ip-address] [detail]
 — no assert
 — bsr [detail]
 — no bsr
 — data [group grp-ip-address] [source ip-address] [detail]
 — no data
 — db [group grp-ip-address] [source ip-address] [detail]
 — no db
 — interface [ip-int-name | mt-int-name] ip-address [detail]
 — no interface
 — jp [group grp-ip-address] [source ip-address] [detail]
 — no jp
 — mrrib[group grp-ip-address] [source ip-address] [detail]
 — no mrrib
 — msg [detail]
 — no msg
 — packet [hello | register | register-stop| jp | bsr | assert | crp] [ip-int-name | ip-
 address]
 — no packet
 — register [group grp-ip-address] [source ip-address] [detail]
 — no register
 — rtm [detail]
 — no rtm
 — s-pmsi [{vpnSrcAddr [vpnGrpAddr]} [mdSrcAddr]] [detail]
 — no s-pmsi

debug
 — router
 — [no] msdp
 — packet [pkt-type] [peer ip-address]
 — no packet

```

## Multicast Command Reference

- **pim** [*grp-address*]
- **no pim**
- **rtm** [*rp-address*]
- **no rtm**
- **sa-db** [**group** *grpAddr*] [*source srcAddr*] [**rp** *rpAddr*]
- **no sa-db**



---

## Configuration Commands

---

### Generic Commands

#### shutdown

**Syntax** [no] shutdown

**Context** config>router>igmp  
 config>router>igmp>interface  
 config>router>igmp>interface>group-interface  
 config>router>igmp>if>mcac>mc-constraints  
 config>router>pim  
 config>router>pim>interface *ip-int-name*  
 config>router>pim>rp>rp-candidate  
 config>router>pim>rp>bsr-candidate  
 config>router>pim>rp>ipv6>rp-candidate  
 config>router>pim>rp>ipv6>bsr-candidate  
 config>router>pim>if>mcac>mc-constraints  
 config>router>msdp  
 config>router>msdp>peer  
 config>router>msdp>group  
 config>router>mcac>policy>bundle  
 config>router>mld  
 config>router>mld>interface

**Description** The **shutdown** command administratively disables the entity. When disabled, an entity does not change, reset, or remove any configuration settings or statistics. Many entities must be explicitly enabled using the **no shutdown** command.

The **shutdown** command administratively disables an entity. The operational state of the entity is disabled as well as the operational state of any entities contained within. Many objects must be shut down before they may be deleted.

Unlike other commands and parameters where the default state is not indicated in the configuration file, **shutdown** and **no shutdown** are always indicated in system generated configuration files.

The **no** form of the command puts an entity into the administratively enabled state.

**Default** no shutdown: config>router>igmp  
 config>router>igmp>interface *ip-int-name*  
 config>router>pim  
 config>router>pim>rp>rp-candidate  
 shutdown: config>router>pim>rp>bsr-candidate

### ssm-translate

- Syntax** **ssm-translate**
- Context** config>router>igmp>interface>shutdown
- Description** This command adds or removes ssm-translate group ranges.

### SOURCE

- Syntax** [**no**] **source** *ip-address*
- Context** config>router>igmp>interface>shutdown>ssm-translate>grp-range
- Description** This command adds or removes source addresses for the SSM translate group range.
- Parameters** *ip-address* — a.b.c.d - unicast source address

### grp-range

- Syntax** [**no**] **grp-range** *start end*
- Context** config>router>igmp>interface>shutdown>ssm-translate
- Description** This command adds or removes SSM translate group range entries.
- Parameters** *start* — a.b.c.d - multicast group range start address  
*end* — a.b.c.d - multicast group range end address

### description

- Syntax** **description** *description-string*  
**no description**
- Context** config>router>mcac>policy  
config>router>mcac>policy>bundle
- Description** This command creates a text description stored in the configuration file for a configuration context.  
The **description** command associates a text string with a configuration context to help identify the context in the configuration file.  
The **no** form of the command removes any description string from the context.
- Default** No description associated with the configuration context.
- Parameters** *string* — The description character string. Allowed values are any string up to 80 characters long composed of printable, 7-bit ASCII characters. If the string contains special characters (#, \$, spaces, etc.), the entire string must be enclosed within double quotes.

## ip-fast-reroute

**Syntax** [no] ip-fast-reroute

**Context** config>router

**Description** This command configures IP fast reroute.

## mc-maximum-routes

**Syntax** mc-maximum-routes *number* [log-only] [threshold *threshold*]  
no mc-maximum-routes

**Context** config>router

**Description** This command specifies the maximum number of multicast routes that can be held within a VPN routing/forwarding (VRF) context. When this limit is reached, a log and SNMP trap are sent. If the **log-only** parameter is not specified and the maximum-routes value is set below the existing number of routes in a VRF, then no new joins will be processed.

The **no** form of the command disables the limit of multicast routes within a VRF context. Issue the **no** form of the command only when the VPRN instance is shutdown.

**Default** no mc-maximum-routes

**Parameters** *number* — Specifies the maximum number of routes to be held in a VRF context.

**Values** 1 — 2147483647

**log-only** — Specifies that if the maximum limit is reached, only log the event. **log-only** does not disable the learning of new routes.

**threshold** *threshold* — The percentage at which a warning log message and SNMP trap should be sent.

**Values** 0 — 100

**Default** 1

## multicast-info

**Syntax** multicast-info-policy *policy-name*  
no multicast-info-policy

**Context** configure>router

**Description** This command configures multicast information policy.

**Parameters** *policy-name* — Specifies the policy name.

**Values** 32 chars max

---

## Router IGMP Commands

### igmp

**Syntax** [no] igmp

**Context** config>router

**Description** This command enables the Internet Group Management Protocol (IGMP) context. When the context is created, the IGMP protocol is enabled.

The Internet Group Management Protocol (IGMP) is used by IPv4 systems (hosts and routers) to report their IP multicast group memberships to neighboring multicast routers. An IP multicast router can be a member of one or more multicast groups, in which case it performs both the “multicast router part” of the protocol which collects the membership information needed by its multicast routing protocol, and the “group member part” of the protocol which informs itself and other neighboring multicast routers of its memberships.

The **no** form of the command disables the IGMP instance. To start or suspend execution of IGMP without affecting the configuration, use the **no shutdown** command.

**Default** none

### interface

**Syntax** [no] interface *ip-int-name*

**Context** config>router>igmp

**Description** This command enables the context to configure an IGMP interface. The interface is a local identifier of the network interface on which reception of the specified multicast address is to be enabled or disabled.

The **no** form of the command deletes the IGMP interface. The **shutdown** command in the **config>router>igmp>interface** context can be used to disable an interface without removing the configuration for the interface.

**Default** **no interface** — No interfaces are defined.

**Parameters** *ip-int-name* — The IP interface name. Interface names must be unique within the group of defined IP interfaces for **config router interface** and **config service ies interface** commands. An interface name cannot be in the form of an IP address. Interface names can be any string up to 32 characters long composed of printable, 7-bit ASCII characters. If the string contains special characters (#, \$, spaces, etc.), the entire string must be enclosed within double quotes.

If the IP interface name does not exist or does not have an IP address configured an error message will be returned.

If the IP interface exists in a different area it will be moved to this area.

## disable-router-alert-check

**Syntax** [no] **disable-router-alert-check**

**Context** config>router>igmp>if

**Description** This command enables the router alert checking for IGMP messages received on this interface. The **no** form of the command disables the IGMP router alert check option.

## group-interface

**Syntax** [no] **group-interface** *ip-int-name*

**Context** config>router>igmp>if

**Description** This command configures an IGMP group interface.

## import

**Syntax** **import** *policy-name*  
**no import**

**Context** config>router>igmp>if

**Description** This command specifies the import route policy to be used for determining which membership reports are accepted by the router. Route policies are configured in the **config>router>policy-options** context.

When an import policy is not specified, all the IGMP reports are accepted.

The **no** form of the command removes the policy association from the IGMP instance.

**Default** **no import** — No import policy specified.

**Parameters** *policy-name* — The route policy name. Allowed values are any string up to 32 characters long composed of printable, 7-bit ASCII characters. If the string contains special characters (#, \$, spaces, etc.), the entire string must be enclosed within double quotes. Route policies are configured in the **config>router>policy-options** context.

## max-groups

**Syntax** **max-groups** *value*  
**no max-groups**

**Context** config>router>igmp>if  
config>router>pim>if

**Description** This command specifies the maximum number of groups for which IGMP can have local receiver information based on received IGMP reports on this interface. When this configuration is changed

## Configuration Commands

dynamically to a value lower than the currently accepted number of groups, the groups that are already accepted are not deleted. Only new groups will not be allowed. This command is applicable for IPv4 and IPv6.

**Default** 0, no limit to the number of groups.

**Parameters** *value* — Specifies the maximum number of groups for this interface.

**Values** 1 — 16000

### static

**Syntax** **static**

**Context** config>router>igmp>if

**Description** This command tests multicast forwarding on an interface without a receiver host. When enabled, data is forwarded to an interface without receiving membership reports from host members.

**Default** none

### group

**Syntax** [**no**] **group** grp-ip-address

**Context** config>router>igmp>if>static

**Description** This command enables the context to add a static multicast group either as a (\*,G) or one or more (S,G) records. Use IGMP static group memberships to test multicast forwarding without a receiver host. When IGMP static groups are enabled, data is forwarded to an interface without receiving membership reports from host members.

When static IGMP group entries on point-to-point links that connect routers to a rendezvous point (RP) are configured, the static IGMP group entries do not generate join messages toward the RP.

**Default** none

**Parameters** *grp-ip-address* — Specifies an IGMP multicast group address that receives data on an interface. The IP address must be unique for each static group.

### SOURCE

**Syntax** [**no**] **source** ip-address

**Context** config>router>igmp>if>static>group  
config>router>igmp>ssm-translate>grp-range

|                    |                                                                                                                                                                                                                                                                                                                                                                                                                                                                                                                                                                                    |
|--------------------|------------------------------------------------------------------------------------------------------------------------------------------------------------------------------------------------------------------------------------------------------------------------------------------------------------------------------------------------------------------------------------------------------------------------------------------------------------------------------------------------------------------------------------------------------------------------------------|
| <b>Description</b> | <p>This command specifies a IPv4 unicast address that sends data on an interface. This enables a multicast receiver host to signal a router the group to receive multicast traffic from, and from the source(s) that the traffic is expected.</p> <p>The <b>source</b> command is mutually exclusive with the specification of individual sources for the same group.</p> <p>The source command in combination with the group is used to create a specific (S,G) static group entry.</p> <p>Use the <b>no</b> form of the command to remove the source from the configuration.</p> |
| <b>Default</b>     | none                                                                                                                                                                                                                                                                                                                                                                                                                                                                                                                                                                               |
| <b>Parameters</b>  | <i>ip-address</i> — Specifies the IPv4 unicast address.                                                                                                                                                                                                                                                                                                                                                                                                                                                                                                                            |

## starg

|                    |                                                                                                                                                                                                                                              |
|--------------------|----------------------------------------------------------------------------------------------------------------------------------------------------------------------------------------------------------------------------------------------|
| <b>Syntax</b>      | <b>[no] starg</b>                                                                                                                                                                                                                            |
| <b>Context</b>     | config>router>igmp>if>static>group                                                                                                                                                                                                           |
| <b>Description</b> | <p>This command adds a static (*,G) entry. This command can only be enabled if no existing source addresses for this group are specified.</p> <p>Use the <b>no</b> form of the command to remove the starg entry from the configuration.</p> |
| <b>Default</b>     | none                                                                                                                                                                                                                                         |

## subnet-check

|                    |                                                                                                                                                                               |
|--------------------|-------------------------------------------------------------------------------------------------------------------------------------------------------------------------------|
| <b>Syntax</b>      | <b>[no] subnet-check</b>                                                                                                                                                      |
| <b>Context</b>     | config>router>igmp>interface                                                                                                                                                  |
| <b>Description</b> | <p>This command enables subnet checking for IGMP messages received on this interface. All IGMP packets with a source address that is not in the local subnet are dropped.</p> |
| <b>Default</b>     | enabled                                                                                                                                                                       |

## version

|                    |                                                                                                                                                                                                                                                                                                                                                 |
|--------------------|-------------------------------------------------------------------------------------------------------------------------------------------------------------------------------------------------------------------------------------------------------------------------------------------------------------------------------------------------|
| <b>Syntax</b>      | <b>version</b> <i>version</i><br><b>no version</b>                                                                                                                                                                                                                                                                                              |
| <b>Context</b>     | config>router>igmp>if                                                                                                                                                                                                                                                                                                                           |
| <b>Description</b> | <p>This command specifies the IGMP version. If routers run different versions of IGMP, they will negotiate the lowest common version of IGMP that is supported by hosts on their subnet and operate in that version. For IGMP to function correctly, all routers on a LAN should be configured to run the same version of IGMP on that LAN.</p> |

## Configuration Commands

For IGMPv3, note that a multicast router that is also a group member performs both parts of IGMPv3, receiving and responding to its own IGMP message transmissions as well as those of its neighbors.

**Default** 3

**Parameters** *version* — Specifies the IGMP version number.

**Values** 1, 2, 3

**Values**  $\geq 1000$

### query-interval

**Syntax** **query-interval** *seconds*  
**no query-interval**

**Context** config>router>igmp

**Description** This command specifies the frequency that the querier router transmits general host-query messages. The host-query messages solicit group membership information and are sent to the all-systems multicast group address, 224.0.0.1.

**Default** 125

*seconds* — The time frequency, in seconds, that the router transmits general host-query messages.

**Values** 2 — 1024

### query-last-member-interval

**Syntax** **query-last-member-interval** *seconds*

**Context** config>router>igmp

**Description** This command configures the frequency at which the querier sends group-specific query messages including messages sent in response to leave-group messages. The lower the interval, the faster the detection of the loss of the last member of a group.

**Default** 1

**Parameters** *seconds* — Specifies the frequency, in seconds, at which query messages are sent.

**Values** 1 — 1024



## query-response-interval

|                    |                                                                                                                          |
|--------------------|--------------------------------------------------------------------------------------------------------------------------|
| <b>Syntax</b>      | <b>query-response-interval</b> <i>seconds</i>                                                                            |
| <b>Context</b>     | config>router>igmp                                                                                                       |
| <b>Description</b> | This command specifies how long the querier router waits to receive a response to a host-query message from a host.      |
| <b>Default</b>     | 10                                                                                                                       |
| <b>Parameters</b>  | <i>seconds</i> — Specifies the the length of time to wait to receive a response to the host-query message from the host. |
| <b>Values</b>      | 1 — 1023                                                                                                                 |

## robust-count

|                    |                                                                                                                                                                                                         |
|--------------------|---------------------------------------------------------------------------------------------------------------------------------------------------------------------------------------------------------|
| <b>Syntax</b>      | <b>robust-count</b> <i>robust-count</i><br><b>no robust-count</b>                                                                                                                                       |
| <b>Context</b>     | config>router>igmp                                                                                                                                                                                      |
| <b>Description</b> | This command configures the robust count. The robust-count variable allows tuning for the expected packet loss on a subnet. If a subnet anticipates losses, the robust-count variable can be increased. |
| <b>Default</b>     | 2                                                                                                                                                                                                       |
| <b>Parameters</b>  | <i>robust-count</i> — Specify the robust count value.                                                                                                                                                   |
| <b>Values</b>      | 2 — 10                                                                                                                                                                                                  |

## ssm-translate

|                    |                                                                                                                                                                                                                                                                                                                                                                                                                                                  |
|--------------------|--------------------------------------------------------------------------------------------------------------------------------------------------------------------------------------------------------------------------------------------------------------------------------------------------------------------------------------------------------------------------------------------------------------------------------------------------|
| <b>Syntax</b>      | <b>ssm-translate</b>                                                                                                                                                                                                                                                                                                                                                                                                                             |
| <b>Context</b>     | config>router>igmp                                                                                                                                                                                                                                                                                                                                                                                                                               |
| <b>Description</b> | This command enables the context to configure group ranges which are translated to SSM (S,G) entries. If the static entry needs to be created, it has to be translated from a IGMPv1 IGMPv2 request to a Source Specific Multicast (SSM) join. An SSM translate source can only be added if the starg command is not enabled. An error message is generated if you try to configure the <b>source</b> command with <b>starg</b> command enabled. |

## Configuration Commands

### grp-range

**Syntax** [no] **grp-range** *start end*

**Context** config>router>igmp>ssm-translate

**Description** This command is used to configure group ranges which are translated to SSM (S,G) entries.

**Parameters** *start* — An IP address that specifies the start of the group range.

*end* — An IP address that specifies the end of the group range. This value should always be greater than or equal to the value of the *start* value.

### source

**Syntax** [no] **source** *ip-address*

**Context** config>router>igmp>ssm-translate>grp-range

**Description** This command specifies the source IP address for the group range. Whenever a (\*,G) report is received in the range specified by **grp-range** *start* and *end* parameters, it is translated to an (S,G) report with the value of this object as the source address.

**Parameters** *ip-address* — Specifies the IP address that will be sending data.

### tunnel-interface

**Syntax** [no] **tunnel-interface** {**rsvp-p2mp** *lsp-name* [**sender** *sender-address*] | **ldp-p2mp** *p2mp-id* **sender** *sender-address* [**root-node**]}

**Context** config>router  
config>router>igmp

**Description** This command creates a tunnel interface associated with an RSVP P2MP LSP. IPv4 multicast packets are forwarded over the P2MP LSP at the ingress LER based on a static join configuration of the multicast group against the tunnel interface associated with the originating P2MP LSP. At the egress LER, packets of a multicast group are received from the P2MP LSP via a static assignment of the specific <S,G> to the tunnel interface associated with a terminating LSP.

At ingress LER, the tunnel interface identifier consists of a string of characters representing the LSP name for the RSVP P2MP LSP. The user can create one or more tunnel interfaces in PIM and associate each to a different RSVP P2MP LSP. P2mp-ID is required to configure LDP P2MP LSP tunnel interfaces. Sender address for a tunnel interface must be specified only on the leaf node.

At egress LER, the tunnel interface identifier consists of a couple of string of characters representing the LSP name for the RSVP P2MP LSP followed by the system address of the ingress LER. The LSP name must correspond to a P2MP LSP name configured by the user at the ingress LER. The LSP name string must not contain “:.” (two :s) nor contain a “.” (single “.”) at the end of the LSP name. However, a “.” (single “.”) can appear anywhere in the string except at the end of the name.

**Default** none

**Parameters** **rsvp-p2mp** *lsp-name* — Specifies the LSP. The LSP name can be up to 32 characters long and must be unique.

*p2mp-id* — Identifier used for signaling mLDP P2MP LSP.

**Values** 1 – 4294967296 (On Leaf Node)

**Values** 1-8192 (On Root Node)

## static

**Syntax** **static**

**Context** config>router>igmp>tunnel-interface

**Description** This command provides the context to configure static multicast receiver hosts on a tunnel interface associated with an RSVP P2MP LSP.

When enabled, data is forwarded to an interface without receiving membership reports from host members.

**Default** none

## group

**Syntax** [**no**] **group** *grp-ip-address*

**Context** config>router>igmp>tunnel-interface>static

**Description** This command enables the context to add a static multicast group either as a (\*,G) or one or more (S,G) records.

The user can assign static multicast group joins to a tunnel interface associated with an RSVP P2MP LSP. Note that a given <\*,G> or <S,G> can only be associated with a single tunnel interface.

A multicast packet which is received on an interface and which succeeds the RPF check for the source address will be replicated and forwarded to all OIFs which correspond to the branches of the P2MP LSP. The packet is sent on each OIF with the label stack indicated in the NHLFE of this OIF. The packets will also be replicated and forwarded natively on all OIFs which have received IGMP or PIM joins for this <S,G>.

The multicast packet can be received over a PIM or IGMP interface which can be an IES interface, a spoke SDP terminated IES interface, or a network interface.

**Default** none

**Parameters** *grp-ip-address* — Specifies a multicast group address that receives data on a tunnel interface. The IP address must be unique for each static group.

## Configuration Commands

### SOURCE

**Syntax** [no] source *ip-address*

**Context** config>router>igmp>tunnel-interface>static>group

**Description** This command specifies a IPv4 unicast address of a multicast source. The source command is mutually exclusive with the specification of individual sources for the same group. The source command in combination with the group is used to create a specific (S,G) group entry in a static group join on a tunnel interface associated with a P2MP RSVP LSP.

The **no** form of the command removes the source from the configuration.

**Default** none

**Parameters** *ip-address* — Specifies the IPv4 unicast address.

### starg

**Syntax** [no] starg

**Context** config>router>igmp>tunnel-interface>static>group

**Description** This command adds a static (\*,G) group entry in a static group join on a tunnel interface associated with a P2MP RSVP LSP.

This command can only be enabled if no existing source addresses for this group are specified.

The **no** form of the command removes the starg entry from the configuration.

**Default** none

---

## Router PIM Commands

### pim

**Syntax** [no] pim

**Context** config>router

**Description** This command configures a Protocol Independent Multicast (PIM) instance. PIM is used for multicast routing within the network. Devices in the network can receive the multicast feed requested and non-participating routers can be pruned. The 7750 SR OS supports PIM sparse mode (PIM-SM).

**Default** not enabled

### interface

**Parameters** [no] interface *ip-int-name*

**Context** config>router>pim

**Description** This command creates a logical IP routing interface. Interface names are case-sensitive and must be unique within the group of defined IP interfaces defined for **config router interface** and **config service ies interface**. Interface names must not be in the dotted decimal notation of an IP address. For example, the name “1.1.1.1” is not allowed, but “int-1.1.1.1” is allowed. Show commands for router interfaces use either the interface names or the IP addresses. Ambiguity can exist if an IP address is used as an IP address and an interface name. Duplicate interface names can exist in different router instances, although this is not recommended because it is confusing.

The **no** form of the command removes the IP interface and all the associated configurations.

**Default** No interfaces or names are defined within PIM.

**Parameters** *ip-int-name* — The name of the IP interface. Interface names must be unique within the group of defined IP interfaces for **config router interface** and **config service ies interface** commands. An interface name cannot be in the form of an IP address. If the string contains special characters (#, \$, spaces, etc.), the entire string must be enclosed within double quotes.

**Values** 1 — 32 alphanumeric characters.

If the *ip-int-name* already exists, the context is changed to maintain that IP interface. If *ip-int-name* does not exist, the interface is created and the context is changed to that interface for further command processing.

## Configuration Commands

### apply-to

**Syntax** **apply-to** {**ies** | **non-ies** | **all** | **none**}

**Context** config>router>pim

**Description** This command creates a PIM interface with default parameters.

If a manually created or modified interface is deleted, the interface will be recreated when (re)processing the **apply-to** command and if PIM is not required on a specific interface a shutdown should be executed.

The **apply-to** command is first saved in the PIM configuration structure. Then, all subsequent commands either create new structures or modify the defaults as created by the apply-to command.

**Default** none (keyword)

**Parameters** **ies** — Creates all IES interfaces in PIM.

**non-ies** — Non-IES interfaces are created in PIM.

**all** — All IES and non-IES interfaces are created in PIM.

**none** — Removes all interfaces that are not manually created or modified. It also removes explicit no interface commands if present.

### assert-period

**Syntax** **assert-period** *assert-period*  
**no assert-period**

**Context** config>router>pim>if

**Description** This command configures the period for periodic refreshes of PIM Assert messages on an interface. The **no** form of the command removes the assert-period from the configuration.

**Default** no assert-period

**Parameters** *assert-period* — Specifies the period for periodic refreshes of PIM Assert messages on an interface.

**Values** 1 — 300 seconds

### bfd-enable

**Parameters** [**no**] **bfd-enable** [**ipv4** | **ipv6**]

**Context** config>router>pim>interface

**Description** This command enables the use of IPv4 or IPv6 bi-directional forwarding (BFD) to control the state of the associated protocol interface. By enabling BFD on a given protocol interface, the state of the protocol interface is tied to the state of the BFD session between the local node and the remote node. The parameters used for the BFD are set via the BFD command under the IP interface.

The **no** form of this command removes BFD from the associated IGP protocol adjacency.

**Default** no bfd-enable

## enable-mdt-spt

**Syntax** [no] enable-mdt-spt

**Context** config>router>pim

**Description** This command is used to enable SPT switchover for default MDT. On enable, PIM instance resets all MDTs and reinitiate setup.

The **no** form of the command disables SPT switchover for default MDT. On disable, PIM instance resets all MDTs and reinitiate setup.

**Default** no enable-mdt-spt

## import

**Syntax** import {join-policy | register-policy} [*policy-name* [.. *policy-name*]]  
no import {join-policy | register-policy}

**Context** config>router>pim

**Description** This command specifies the import route policy to be used. Route policies are configured in the **config>router>policy-options** context.

When an import policy is not specified, BGP routes are accepted by default. Up to five import policy names can be specified.

The **no** form of the command removes the policy association from the instance.

**Default** no import join-policy  
no import register-policy

**Parameters** **join-policy** — Use this command to filter PIM join messages which prevents unwanted multicast streams from traversing the network.

**register-policy** — This keyword filters register messages. PIM register filters prevent register messages from being processed by the RP. This filter can only be defined on an RP. When a match is found, the RP immediately sends back a register-stop message.

*policy-name* — The route policy name. Allowed values are any string up to 32 characters long composed of printable, 7-bit ASCII characters. If the string contains special characters (#, \$, spaces, etc.), the entire string must be enclosed within double quotes. Route policies are configured in the **config>router>policy-options** context.

## Configuration Commands

### ipv4-multicast-disable

|                    |                                                                        |
|--------------------|------------------------------------------------------------------------|
| <b>Syntax</b>      | <b>[no] ipv4-multicast-disable</b>                                     |
| <b>Context</b>     | configure>router>pim<br>configure>router>pim>interface                 |
| <b>Description</b> | This command administratively disables/enables PIM operation for IPv4. |
| <b>Default</b>     | no ipv4-multicast-disable                                              |

### lag-usage-optimization

|                    |                                                                                                                                                                                                                                                                                                                                                                                                                                                                                                                                                                                                                                                                                       |
|--------------------|---------------------------------------------------------------------------------------------------------------------------------------------------------------------------------------------------------------------------------------------------------------------------------------------------------------------------------------------------------------------------------------------------------------------------------------------------------------------------------------------------------------------------------------------------------------------------------------------------------------------------------------------------------------------------------------|
| <b>Syntax</b>      | <b>[no] lag-usage-optimization</b>                                                                                                                                                                                                                                                                                                                                                                                                                                                                                                                                                                                                                                                    |
| <b>Context</b>     | configure>router>pim                                                                                                                                                                                                                                                                                                                                                                                                                                                                                                                                                                                                                                                                  |
| <b>Description</b> | <p>This command specifies whether the router should optimize usage of the LAG such that traffic for a given multicast stream destined to an IP interface using the LAG is sent only to the forwarding complex that owns the LAG link on which it will actually be forwarded.</p> <p>Changing the value causes the PIM protocol to be restarted.</p> <p>If this optimization is disabled, the traffic will be sent to all the forwarding complexes that own at least one link in the LAG.</p> <p>Note that changes made for 9G multicast hashing causes Layer 4 multicast traffic to not hashed. This is independent whether <b>lag-usage-optimization</b> is enabled or disabled.</p> |

### mc-ecmp-balance

|                    |                                                                                                                                                                                                                                                                                                                                                                     |
|--------------------|---------------------------------------------------------------------------------------------------------------------------------------------------------------------------------------------------------------------------------------------------------------------------------------------------------------------------------------------------------------------|
| <b>Syntax</b>      | <b>[no] mc-ecmp-balance</b>                                                                                                                                                                                                                                                                                                                                         |
| <b>Context</b>     | configure>router>pim                                                                                                                                                                                                                                                                                                                                                |
| <b>Description</b> | <p>This command enables multicast balancing of traffic over ECMP links. When enabled, each multicast stream that needs to be forwarded over an ECMP link will be re-evaluated for the total multicast bandwidth utilization. Re-evaluation occurs on the ECMP interface in question.</p> <p>The <b>no</b> form of the command disables the multicast balancing.</p> |

### mc-ecmp-balance-hold

|                    |                                                                                |
|--------------------|--------------------------------------------------------------------------------|
| <b>Syntax</b>      | <b>mc-ecmp-balance-hold</b> <i>minutes</i><br><b>no mc-ecmp-balance-hold</b>   |
| <b>Context</b>     | configure>router>pim                                                           |
| <b>Description</b> | This command configures the hold time for multicast balancing over ECMP links. |



**Parameters** *minutes* — Specifies the hold time, in minutes, that applies after an interface has been added to the ECMP link.

## mc-ecmp-hashing-enabled

**Syntax** `[no] mc-ecmp-hashing-enabled`

**Context** `configure>router>pim`

**Description** This command enables hash-based multicast balancing of traffic over ECMP links and causes PIM joins to be distributed over the multiple ECMP paths based on a hash of S and G (and possibly next-hop IP). When a link in the ECMP set is removed, the multicast streams that were using that link are re-distributed over the remaining ECMP links using the same hash algorithm. When a link is added to the ECMP set new joins may be allocated to the new link based on the hash algorithm, but existing multicast streams using the other ECMP links stay on those links until they are pruned.

Hash-based multicast balancing is supported for both IPv4 and IPv6.

This command is mutually exclusive with the `mc-ecmp-balance` command in the same context.

The **no** form of the command disables the hash-based multicast balancing of traffic over ECMP links.

**Default** `no mc-ecmp-hashing-enabled`

## ipv6-multicast-disable

**Syntax** `ipv6-multicast-disable`

**Context** `configure>router>pim`  
`configure>router>pim>interface`

**Description** This command administratively disables/enables PIM operation for IPv6.

**Default** `ipv6-multicast-disable`

## bsm-check-rtr-alert

**Syntax** `[no] bsm-check-rtr-alert`

**Context** `config>router>pim>interface`

**Description** This command enables the checking of the router alert option in the bootstrap messages received on this interface.

**Default** `no bsm-check-rtr-alert`

## hello-interval

|                    |                                                                                                                                                                                                                |
|--------------------|----------------------------------------------------------------------------------------------------------------------------------------------------------------------------------------------------------------|
| <b>Syntax</b>      | <b>hello-interval</b> <i>hello-interval</i><br><b>no hello-interval</b>                                                                                                                                        |
| <b>Context</b>     | config>router>pim>interface                                                                                                                                                                                    |
| <b>Description</b> | This command configures the frequency at which PIM Hello messages are transmitted on this interface. The <b>no</b> form of this command reverts to the default value of the hello-interval.                    |
| <b>Default</b>     | <b>30</b>                                                                                                                                                                                                      |
| <b>Parameters</b>  | <i>hello-interval</i> — Specifies the hello interval in seconds. A 0 (zero) value disables the sending of hello messages (the PIM neighbor will never timeout the adjacency).<br><b>Values</b> 0 — 255 seconds |

## hello-multiplier

|                    |                                                                                                                                                                                                                                                                                                                                               |
|--------------------|-----------------------------------------------------------------------------------------------------------------------------------------------------------------------------------------------------------------------------------------------------------------------------------------------------------------------------------------------|
| <b>Syntax</b>      | <b>hello-multiplier</b> <i>deci-units</i><br><b>no hello-multiplier</b>                                                                                                                                                                                                                                                                       |
| <b>Context</b>     | config>router>pim>interface                                                                                                                                                                                                                                                                                                                   |
| <b>Description</b> | This command configures the multiplier to determine the holdtime for a PIM neighbor on this interface. The <b>hello-multiplier</b> in conjunction with the <b>hello-interval</b> determines the holdtime for a PIM neighbor.                                                                                                                  |
| <b>Parameters</b>  | <i>deci-units</i> — Specify the value, specified in multiples of 0.1, for the formula used to calculate the hello-holdtime based on the hello-multiplier:<br>$(\text{hello-interval} * \text{hello-multiplier}) / 10$<br>This allows the PIMv2 default timeout of 3.5 seconds to be supported.<br><b>Values</b> 20 — 100<br><b>Default</b> 35 |

## improved-assert

|                    |                                                                                                                                                                                                                                                                                                                                                                                                                                                                                                                                                                                                                                       |
|--------------------|---------------------------------------------------------------------------------------------------------------------------------------------------------------------------------------------------------------------------------------------------------------------------------------------------------------------------------------------------------------------------------------------------------------------------------------------------------------------------------------------------------------------------------------------------------------------------------------------------------------------------------------|
| <b>Syntax</b>      | <b>[no] improved-assert</b>                                                                                                                                                                                                                                                                                                                                                                                                                                                                                                                                                                                                           |
| <b>Context</b>     | config>router>pim>interface                                                                                                                                                                                                                                                                                                                                                                                                                                                                                                                                                                                                           |
| <b>Description</b> | The PIM assert process establishes a forwarder for a LAN and requires interaction between the control and forwarding planes. The assert process is started when data is received on an outgoing interface meaning that duplicate traffic is forwarded to the LAN until the forwarder is negotiated among the routers.<br>When the <b>improved-assert</b> command is enabled, the PIM assert process is done entirely in the control plane. The advantages are that it eliminates duplicate traffic forwarding to the LAN. It also improves performance since it removes the required interaction between the control and data planes. |

NOTE: improved-assert is still fully interoperable with the draft-ietf-pim-sm-v2-new-xx, *Protocol Independent Multicast - Sparse Mode (PIM-SM): Revised*, and RFC 2362, *Protocol Independent Multicast-Sparse Mode (PIM-SM)*, implementations. However, there may be conformance tests that may fail if the tests expect control-data plane interaction in determining the assert winner. Disabling the **improved-assert** command when performing conformance tests is recommended.

**Default** enabled

## multicast-senders

**Syntax** **multicast-senders {auto | always | never}**  
**no multicast-senders**

**Context** config>router>pim>interface

**Description** This command configures how traffic from directly-attached multicast sources should be treated on broadcast interfaces. It can also be used to treat all traffic received on an interface as traffic coming from a directly-attached multicast source. This is particularly useful if a multicast source is connected to a point-to-point or unnumbered interface.

**Default** auto

**Parameters** **auto** — Specifies that, on broadcast interfaces, the forwarding plane performs subnet-match check on multicast packets received on the interface to determine if the packet is from a directly-attached source. On unnumbered/point-to-point interfaces, all traffic is implicitly treated as coming from a remote source.

**always** — Treats all traffic received on the interface as coming from a directly-attached multicast source.

**never** — Specifies that, on broadcast interfaces, traffic from directly-attached multicast sources will not be forwarded. Note that traffic from a remote source will still be forwarded if there is a multicast state for it. On unnumbered/point-to-point interfaces, it means that all traffic received on that interface must not be forwarded.

## p2mp-ldp-tree-join

**Syntax** **[no] p2mp-ldp-tree-join**

**Context** config>router>pim>interface

**Description** This command configures the option to join P2MP LDP tree towards the multicast source. If p2mp-ldp-tree-join is enabled, a PIM multicast join received on an interface is processed to join P2MP LDP LSP using the in-band signaled P2MP tree for the same multicast flow. LDP P2MP tree is setup towards the multicast source. Route to source of the multicast node is looked up from the RTM. The next-hop address for the route to source is set as the root of LDP P2MP tree.

The **no** form of command disables joining P2MP LDP tree.

**Default** no p2mp-ldp-tree-join

## Configuration Commands

### priority

|                    |                                                                                                                                                                                                                                                               |
|--------------------|---------------------------------------------------------------------------------------------------------------------------------------------------------------------------------------------------------------------------------------------------------------|
| <b>Syntax</b>      | <b>priority</b> <i>dr-priority</i><br><b>no priority</b>                                                                                                                                                                                                      |
| <b>Context</b>     | config>router>pim>interface                                                                                                                                                                                                                                   |
| <b>Description</b> | This command sets the priority value to elect the designated router (DR). The DR election priority is a 32-bit unsigned number and the numerically larger priority is always preferred.<br><br>The <b>no</b> form of the command restores the default values. |
| <b>Default</b>     | <b>1</b>                                                                                                                                                                                                                                                      |
| <b>Parameters</b>  | <i>priority</i> — Specifies the priority to become the designated router. The higher the value, the higher the priority.<br><br><b>Values</b> 1 — 4294967295                                                                                                  |

### priority

|                    |                                                                                                                                                                                                                                                                                                                |
|--------------------|----------------------------------------------------------------------------------------------------------------------------------------------------------------------------------------------------------------------------------------------------------------------------------------------------------------|
| <b>Syntax</b>      | <b>priority</b> <i>bootstrap-priority</i><br><b>no priority</b>                                                                                                                                                                                                                                                |
| <b>Context</b>     | config>router>pim>rp>bsr-candidate                                                                                                                                                                                                                                                                             |
| <b>Description</b> | This command configures the bootstrap priority of the router. The RP is sometimes called the bootstrap router. The priority determines if the router is eligible to be a bootstrap router. In the case of a tie, the router with the highest IP address is elected to be the bootstrap router.                 |
| <b>Default</b>     | 0                                                                                                                                                                                                                                                                                                              |
| <b>Parameters</b>  | <i>bootstrap-priority</i> — Specifies the priority to become the bootstrap router. The higher the value, the higher the priority. A 0 value the router is not eligible to be the bootstrap router. A value of 1 means router is the least likely to become the designated router.<br><br><b>Values</b> 0 — 255 |

### priority

|                    |                                                                                                                                           |
|--------------------|-------------------------------------------------------------------------------------------------------------------------------------------|
| <b>Syntax</b>      | <b>priority</b> <i>priority</i><br><b>no priority</b>                                                                                     |
| <b>Context</b>     | config>router>pim>rp>rp-candidate<br>config>router>pim>rp>ipv6>rp-candidate                                                               |
| <b>Description</b> | This command configures the Candidate-RP priority for becoming a rendezvous point (RP). This value is used to elect RP for a group range. |
| <b>Default</b>     | 192                                                                                                                                       |

**Parameters** *priority* — Specifies the priority to become a rendezvous point (RP). A value of 0 is considered as the highest priority.

**Values** 0 — 255

## sticky-dr

**Syntax** **sticky-dr** [**priority** *dr-priority*]  
**no sticky-dr**

**Context** config>router>pim>interface

**Description** This command enables sticky-dr operation on this interface. When enabled, the priority in PIM hellos sent on this interface when elected as the designated router (DR) will be modified to the value configured in *dr-priority*. This is done to avoid the delays in forwarding caused by DR recovery, when switching back to the old DR on a LAN when it comes back up.

By enabling **sticky-dr** on this interface, it will continue to act as the DR for the LAN even after the old DR comes back up.

The **no** form of the command disables sticky-dr operation on this interface.

**Default** disabled

**Parameters** **priority** *dr-priority* — Sets the DR priority to be sent in PIM Hello messages following the election of that interface as the DR, when sticky-dr operation is enabled.

**Values** 1 — 4294967295

## three-way-hello

**Syntax** **three-way-hello** [**compatibility-mode**]  
**no three-way-hello**

**Context** config>router>pim>interface

**Description** This command configures the compatibility mode to enable three-way hello. By default value is disabled on all interface which specifies that the standard two-way hello is supported. When enabled, the three way hello is supported.

**Default** no three-way-hello

## tracking-support

**Syntax** [**no**] **tracking-support**

**Context** config>router>pim>interface

## Configuration Commands

**Description** This command sets the the T bit in the LAN Prune Delay option of the Hello Message. This indicates the router's capability to enable join message suppression. This capability allows for upstream routers to explicitly track join membership.

**Default** no tracking-support

### rp

**Syntax** rp

**Context** config>router>pim

**Description** This command enables the context to configure rendezvous point (RP) parameters. The address of the root of the group's shared multicast distribution tree is known as its RP. Packets received from a source upstream and join messages from downstream routers rendezvous at this router.

If this command is not enabled, then the router can never become the RP.

### ipv6

**Syntax** ipv6

**Context** config>router>pim>rp

**Description** This command enables the context to configure IPv6 parameters.

### anycast

**Syntax** [**no**] **anycast** *rp-ip-address*

**Context** config>router>pim>rp  
config>router>pim>rp>ipv6

**Description** This command configures a PIM anycast protocol instance for the RP being configured. Anycast enables fast convergence when a PIM RP router fails by allowing receivers and sources to rendezvous at the closest RP.

The **no** form of the command removes the anycast instance from the configuration.

**Default** none

**Parameters** *rp-ip-address* — Configure the loopback IP address shared by all routes that form the RP set for this anycast instance. Only a single address can be configured. If another anycast command is entered with an address then the old address will be replaced with the new address. If no ip-address is entered then the command is simply used to enter the anycast CLI level.

**Values** Any valid loopback address configured on the node.

## auto-rp-discovery

|                    |                                                                                                                                                                                                                                                                                                                                      |
|--------------------|--------------------------------------------------------------------------------------------------------------------------------------------------------------------------------------------------------------------------------------------------------------------------------------------------------------------------------------|
| <b>Syntax</b>      | <b>[no] auto-rp-discovery</b>                                                                                                                                                                                                                                                                                                        |
| <b>Context</b>     | config>router>pim>rp                                                                                                                                                                                                                                                                                                                 |
| <b>Description</b> | This command enables Auto-RP protocol in discovery mode. In discovery mode, RP-mapping and RP-candidate messages are received and forwarded to downstream nodes. RP-mapping messages are received locally to learn about availability of RP nodes present in the network.<br><br>The <b>no</b> form of the command disables auto RP. |
| <b>Default</b>     | no auto-rp-discovery                                                                                                                                                                                                                                                                                                                 |

## rp-set-peer

|                    |                                                                                                                                                                                                                                                                                                                                                                                                                                                                                                                                                                                                                                                                                                                                             |
|--------------------|---------------------------------------------------------------------------------------------------------------------------------------------------------------------------------------------------------------------------------------------------------------------------------------------------------------------------------------------------------------------------------------------------------------------------------------------------------------------------------------------------------------------------------------------------------------------------------------------------------------------------------------------------------------------------------------------------------------------------------------------|
| <b>Syntax</b>      | <b>[no] rp-set-peer</b> <i>ip-address</i>                                                                                                                                                                                                                                                                                                                                                                                                                                                                                                                                                                                                                                                                                                   |
| <b>Context</b>     | config>router>pim>rp>anycast<br>config>router>pim>rp>ipv6>anycast                                                                                                                                                                                                                                                                                                                                                                                                                                                                                                                                                                                                                                                                           |
| <b>Description</b> | This command configures a peer in the anycast rp-set. The address identifies the address used by the other node as the RP candidacy address for the same multicast group address range as configured on this node.<br><br>This is a manual procedure. Caution should be taken to produce a consistent configuration of an RP-set for a given multicast group address range. The priority should be identical on each node and be a higher value than any other configured RP candidate that is not a member of this rp-set.<br><br>Although there is no set maximum number of addresses that can be configured in an rp-set, up to 15 IP addresses is recommended.<br><br>The <b>no</b> form of the command removes an entry from the list. |
| <b>Default</b>     | None                                                                                                                                                                                                                                                                                                                                                                                                                                                                                                                                                                                                                                                                                                                                        |
| <b>Parameters</b>  | <i>ip-address</i> — Specifies a peer in the anycast rp-set.                                                                                                                                                                                                                                                                                                                                                                                                                                                                                                                                                                                                                                                                                 |
| <b>Values</b>      | Any valid ip-address within the scope outlined above.                                                                                                                                                                                                                                                                                                                                                                                                                                                                                                                                                                                                                                                                                       |

## bsr-candidate

|                    |                                                                                     |
|--------------------|-------------------------------------------------------------------------------------|
| <b>Syntax</b>      | <b>bsr-candidate</b>                                                                |
| <b>Context</b>     | config>router>pim>rp<br>config>router>pim>rp>ipv6                                   |
| <b>Description</b> | This command enables the context to configure Candidate Bootstrap (BSR) parameters. |

## Configuration Commands

### rp-candidate

**Syntax** `rp-candidate`

**Context** `config>router>pim>rp`  
`config>router>pim>rp>ipv6`

**Description** This command enables the context to configure the Candidate RP parameters.

Routers use a set of available rendezvous points distributed in Bootstrap messages to get the proper group-to-RP mapping. A set of routers within a domain are also configured as candidate RPs (C-RPs); typically these will be the same routers that are configured as candidate BSRs.

Every multicast group has a shared tree through which receivers learn about new multicast sources and new receivers learn about all multicast sources. The rendezvous point (RP) is the root of this shared tree.

**Default** `shutdown`

### static

**Syntax** `static`

**Context** `config>router>pim>rp`  
`config>router>pim>rp>ipv6`

**Description** This command enables the context to configure static Rendezvous Point (RP) addresses for a multicast group range.

Entries can be created or destroyed. If no IP addresses are configured in the `config>router>pim>rp>static>address` context, then the multicast group to RP mapping is derived from the RP-set messages received from the Bootstrap Router.

### address

**Syntax** `address ip-address`

**Context** `config>router>pim>rp>bsr-candidate`  
`config>router>pim>rp>ipv6>bsr-cand`

**Description** This command is used to configure the candidate BSR IP address. This address is for Bootstrap router election.

**Default** `none`

**Parameters** *ip-address* — The *ip-address* portion of the **address** command specifies the IP host address that will be used by the IP interface within the subnet. This address must be unique within the subnet and specified in dotted decimal notation.

**Values** `1.0.0.0 – 223.255.255.255`



## address

|                    |                                                                                                                                |
|--------------------|--------------------------------------------------------------------------------------------------------------------------------|
| <b>Syntax</b>      | <b>[no] address</b> <i>ip-address</i>                                                                                          |
| <b>Context</b>     | config>router>pim>rp>rp-candidate<br>config>router>pim>rp>ipv6>bsr-cand                                                        |
| <b>Description</b> | This command configures the local RP address. This address is sent in the RP candidate advertisements to the bootstrap router. |
| <b>Default</b>     | none                                                                                                                           |
| <b>Parameters</b>  | <i>ip-address</i> — The <i>ip-address</i> .                                                                                    |
| <b>Values</b>      | 1.0.0.0 – 223.255.255.255                                                                                                      |

## address

|                    |                                                                                                                                                                                                                                                                                              |
|--------------------|----------------------------------------------------------------------------------------------------------------------------------------------------------------------------------------------------------------------------------------------------------------------------------------------|
| <b>Syntax</b>      | <b>address</b> <i>ip-address</i><br><b>no address</b>                                                                                                                                                                                                                                        |
| <b>Context</b>     | config>router>pim>rp>static<br>config>router>pim>rp>ipv6>static                                                                                                                                                                                                                              |
| <b>Description</b> | This command indicates the Rendezvous Point (RP) address that should be used by the router for the range of multicast groups configured by the range command.                                                                                                                                |
| <b>Default</b>     | none                                                                                                                                                                                                                                                                                         |
| <b>Parameters</b>  | <i>ip-address</i> — The static IP address of the RP. The <i>ip-addr</i> portion of the <b>address</b> command specifies the IP host address that will be used by the IP interface within the subnet. This address must be unique within the subnet and specified in dotted decimal notation. |
| <b>Values</b>      | 1.0.0.0 – 223.255.255.255                                                                                                                                                                                                                                                                    |

## embedded-rp

|                    |                                                                                                                                                                                                                                                                                                                                                                                                                                                                                                                                                                                                                                                                                                                                                    |
|--------------------|----------------------------------------------------------------------------------------------------------------------------------------------------------------------------------------------------------------------------------------------------------------------------------------------------------------------------------------------------------------------------------------------------------------------------------------------------------------------------------------------------------------------------------------------------------------------------------------------------------------------------------------------------------------------------------------------------------------------------------------------------|
| <b>Syntax</b>      | <b>[no] embedded-rp</b>                                                                                                                                                                                                                                                                                                                                                                                                                                                                                                                                                                                                                                                                                                                            |
| <b>Context</b>     | config>router>pim>rp>ipv6                                                                                                                                                                                                                                                                                                                                                                                                                                                                                                                                                                                                                                                                                                                          |
| <b>Description</b> | This command enables the context to configure embedded RP parameters.<br><br>Embedded RP is required to support IPv6 inter-domain multicast because there is no MSDP equivalent in IPv6.<br><br>The detailed protocol specification is defined in RFC 3956, <i>Embedding the Rendezvous Point (RP) Address in an IPv6 Multicast Address</i> . This RFC describes a multicast address allocation policy in which the address of the RP is encoded in the IPv6 multicast group address, and specifies a PIM-SM group-to-RP mapping to use the encoding, leveraging, and extending unicast-prefix-based addressing. This mechanism not only provides a simple solution for IPv6 inter-domain ASM but can be used as a simple solution for IPv6 intra- |

## Configuration Commands

domain ASM with scoped multicast addresses as well. It can also be used as an automatic RP discovery mechanism in those deployment scenarios that would have previously used the Bootstrap Router protocol (BSR).

The **no** form of the command disables embedded RP.

### group-range

**Syntax** [no] **group-range** *ipv6-address/prefix-length*

**Context** config>router>pim>ipv6>rp>embedded-rp

**Description** This command defines which multicast groups can embed RP address information besides FF70::/12. Embedded RP information is only used when the multicast group is in FF70::/12 or the configured group range.

**Parameters** *ipv6-address/prefix-length* — Specifies the group range for embedded RP.

|               |                |                                     |
|---------------|----------------|-------------------------------------|
| <b>Values</b> | ipv6-address:  | x:x:x:x:x:x:x (eight 16-bit pieces) |
|               |                | x:x:x:x:x:d.d.d.d                   |
|               | x:             | [0..FFFF]H                          |
|               | d:             | [0..255]D                           |
|               | prefix-length: | 16 — 128                            |

### group-range

**Syntax** [no] **group-range** {*grp-ip-address/mask* | *grp-ip-address netmask*}

**Context** config>router>pim>rp>rp-candidate  
config>router>pim>rp>static>rp>ipv6>rp-candidate

**Description** This command configures the address ranges of the multicast groups for which this router can be an RP.

**Default** none

**Parameters** *grp-ip-address* — The multicast group IP address expressed in dotted decimal notation.

**Values** 224.0.0.0 — 239.255.255.255

*mask* — The mask associated with the IP prefix expressed as a mask length or in dotted decimal notation; for example /16 for a sixteen-bit mask. The mask can also be entered in dotted decimal notation (255.255.0.0).

**Values** 4 — 32

*netmask* — The subnet mask in dotted decimal notation.

**Values** 0.0.0.0 — 255.255.255.255 (network bits all 1 and host bits all 0)

## group-range

|                    |                                                                                                                                                                                                                                                                                                                                                                                                                                                                                                                                                                                                                                                                                                                                                                                                                                                                                                          |               |                      |  |                        |  |                                                  |  |                   |  |               |  |              |  |                         |               |                                                                  |               |                                                                    |
|--------------------|----------------------------------------------------------------------------------------------------------------------------------------------------------------------------------------------------------------------------------------------------------------------------------------------------------------------------------------------------------------------------------------------------------------------------------------------------------------------------------------------------------------------------------------------------------------------------------------------------------------------------------------------------------------------------------------------------------------------------------------------------------------------------------------------------------------------------------------------------------------------------------------------------------|---------------|----------------------|--|------------------------|--|--------------------------------------------------|--|-------------------|--|---------------|--|--------------|--|-------------------------|---------------|------------------------------------------------------------------|---------------|--------------------------------------------------------------------|
| <b>Syntax</b>      | <b>[no] group-range</b> { <i>ip-prefix/mask</i>   <i>ip-prefix netmask</i> }                                                                                                                                                                                                                                                                                                                                                                                                                                                                                                                                                                                                                                                                                                                                                                                                                             |               |                      |  |                        |  |                                                  |  |                   |  |               |  |              |  |                         |               |                                                                  |               |                                                                    |
| <b>Context</b>     | config>router>pim>ssm-groups                                                                                                                                                                                                                                                                                                                                                                                                                                                                                                                                                                                                                                                                                                                                                                                                                                                                             |               |                      |  |                        |  |                                                  |  |                   |  |               |  |              |  |                         |               |                                                                  |               |                                                                    |
| <b>Description</b> | This command configures the address ranges of the multicast groups for this router. When there are parameters present, the command configures the SSM group ranges for IPv6 addresses and netmasks.                                                                                                                                                                                                                                                                                                                                                                                                                                                                                                                                                                                                                                                                                                      |               |                      |  |                        |  |                                                  |  |                   |  |               |  |              |  |                         |               |                                                                  |               |                                                                    |
| <b>Default</b>     | none                                                                                                                                                                                                                                                                                                                                                                                                                                                                                                                                                                                                                                                                                                                                                                                                                                                                                                     |               |                      |  |                        |  |                                                  |  |                   |  |               |  |              |  |                         |               |                                                                  |               |                                                                    |
| <b>Parameters</b>  | <i>ip-prefix/mask</i> — The IP prefix in dotted decimal notation for the range used by the ABR to advertise that summarizes the area into another area. <table> <tr> <td><b>Values</b></td> <td>ipv4-prefix: a.b.c.d</td> </tr> <tr> <td></td> <td>ipv4-prefix-le: 0 — 32</td> </tr> <tr> <td></td> <td>ipv6-prefix: x:x:x:x:x:x:x (eight 16-bit pieces)</td> </tr> <tr> <td></td> <td>x:x:x:x:x:d.d.d.d</td> </tr> <tr> <td></td> <td>x: [0..FFFF]H</td> </tr> <tr> <td></td> <td>d: [0..255]D</td> </tr> <tr> <td></td> <td>ipv6-prefix-le: 0 — 128</td> </tr> </table><br><table> <tr> <td><b>Values</b></td> <td>0 — 32 (mask length), 0.0.0.0 — 255.255.255.255 (dotted decimal)</td> </tr> </table><br><i>netmask</i> — The subnet mask in dotted decimal notation. <table> <tr> <td><b>Values</b></td> <td>0.0.0.0 — 255.255.255.255 (network bits all 1 and host bits all 0)</td> </tr> </table> | <b>Values</b> | ipv4-prefix: a.b.c.d |  | ipv4-prefix-le: 0 — 32 |  | ipv6-prefix: x:x:x:x:x:x:x (eight 16-bit pieces) |  | x:x:x:x:x:d.d.d.d |  | x: [0..FFFF]H |  | d: [0..255]D |  | ipv6-prefix-le: 0 — 128 | <b>Values</b> | 0 — 32 (mask length), 0.0.0.0 — 255.255.255.255 (dotted decimal) | <b>Values</b> | 0.0.0.0 — 255.255.255.255 (network bits all 1 and host bits all 0) |
| <b>Values</b>      | ipv4-prefix: a.b.c.d                                                                                                                                                                                                                                                                                                                                                                                                                                                                                                                                                                                                                                                                                                                                                                                                                                                                                     |               |                      |  |                        |  |                                                  |  |                   |  |               |  |              |  |                         |               |                                                                  |               |                                                                    |
|                    | ipv4-prefix-le: 0 — 32                                                                                                                                                                                                                                                                                                                                                                                                                                                                                                                                                                                                                                                                                                                                                                                                                                                                                   |               |                      |  |                        |  |                                                  |  |                   |  |               |  |              |  |                         |               |                                                                  |               |                                                                    |
|                    | ipv6-prefix: x:x:x:x:x:x:x (eight 16-bit pieces)                                                                                                                                                                                                                                                                                                                                                                                                                                                                                                                                                                                                                                                                                                                                                                                                                                                         |               |                      |  |                        |  |                                                  |  |                   |  |               |  |              |  |                         |               |                                                                  |               |                                                                    |
|                    | x:x:x:x:x:d.d.d.d                                                                                                                                                                                                                                                                                                                                                                                                                                                                                                                                                                                                                                                                                                                                                                                                                                                                                        |               |                      |  |                        |  |                                                  |  |                   |  |               |  |              |  |                         |               |                                                                  |               |                                                                    |
|                    | x: [0..FFFF]H                                                                                                                                                                                                                                                                                                                                                                                                                                                                                                                                                                                                                                                                                                                                                                                                                                                                                            |               |                      |  |                        |  |                                                  |  |                   |  |               |  |              |  |                         |               |                                                                  |               |                                                                    |
|                    | d: [0..255]D                                                                                                                                                                                                                                                                                                                                                                                                                                                                                                                                                                                                                                                                                                                                                                                                                                                                                             |               |                      |  |                        |  |                                                  |  |                   |  |               |  |              |  |                         |               |                                                                  |               |                                                                    |
|                    | ipv6-prefix-le: 0 — 128                                                                                                                                                                                                                                                                                                                                                                                                                                                                                                                                                                                                                                                                                                                                                                                                                                                                                  |               |                      |  |                        |  |                                                  |  |                   |  |               |  |              |  |                         |               |                                                                  |               |                                                                    |
| <b>Values</b>      | 0 — 32 (mask length), 0.0.0.0 — 255.255.255.255 (dotted decimal)                                                                                                                                                                                                                                                                                                                                                                                                                                                                                                                                                                                                                                                                                                                                                                                                                                         |               |                      |  |                        |  |                                                  |  |                   |  |               |  |              |  |                         |               |                                                                  |               |                                                                    |
| <b>Values</b>      | 0.0.0.0 — 255.255.255.255 (network bits all 1 and host bits all 0)                                                                                                                                                                                                                                                                                                                                                                                                                                                                                                                                                                                                                                                                                                                                                                                                                                       |               |                      |  |                        |  |                                                  |  |                   |  |               |  |              |  |                         |               |                                                                  |               |                                                                    |

## holdtime

|                    |                                                                                                                                                                                        |               |         |
|--------------------|----------------------------------------------------------------------------------------------------------------------------------------------------------------------------------------|---------------|---------|
| <b>Syntax</b>      | <b>holdtime</b> <i>holdtime</i><br><b>no holdtime</b>                                                                                                                                  |               |         |
| <b>Context</b>     | config>router>pim>rp>rp-candidate<br>config>router>pim>rp>ipv6>rp-candidate                                                                                                            |               |         |
| <b>Description</b> | This command configures the length of time, in seconds, that neighbors should consider the sending router to be operationally up. A local RP cannot be configured on a logical router. |               |         |
| <b>Parameters</b>  | <i>holdtime</i> — Specifies the hold time, in seconds. <table> <tr> <td><b>Values</b></td> <td>5 — 255</td> </tr> </table>                                                             | <b>Values</b> | 5 — 255 |
| <b>Values</b>      | 5 — 255                                                                                                                                                                                |               |         |

## group-prefix

|                |                                                                                         |
|----------------|-----------------------------------------------------------------------------------------|
| <b>Syntax</b>  | <b>[no] group-prefix</b> { <i>grp-ip-address/mask</i>   <i>grp-ip-address netmask</i> } |
| <b>Context</b> | config>router>pim>rp>static>address<br>config>router>pim>rp>ipv6>static>address         |

## Configuration Commands

**Description** This command specifies the range of multicast group addresses which should be used by the router as the Rendezvous Point (RP). The `config>router>pim>rp>static>address a.b.c.d` implicitly defaults to deny all for all multicast groups (224.0.0.0/4). A group-prefix must be specified for that static address. This command does not apply to the whole group range.

The **no** form of the command removes the group-prefix from the configuration.

**Default** none

**Parameters** *grp-ip-address* — The multicast group IP address expressed in dotted decimal notation.

**Values** 224.0.0.0 — 239.255.255.255

*mask* — The mask associated with the IP prefix expressed as a mask length or in dotted decimal notation; for example /16 for a sixteen-bit mask. The mask can also be entered in dotted decimal notation (255.255.0.0).

**Values** 4 — 32

*netmask* — The subnet mask in dotted decimal notation.

**Values** 0.0.0.0 — 255.255.255.255 (network bits all 1 and host bits all 0)

## override

**Syntax** [**no**] **override**

**Context** `config>router>pim>rp>static>address`  
`config>router>pim>rp>ipv6>static>address`

**Description** This command changes the precedence of static RP over dynamically learned Rendezvous Point (RP). When enabled, the static group-to-RP mappings take precedence over the dynamically learned mappings.

**Default** no override

## non-dr-attract-traffic

**Syntax** [**no**] **non-dr-attract-traffic**

**Context** `config>router>pim`

**Description** This command specifies whether the router should ignore the designated router state and attract traffic even when it is not the designater router.

An operator can configure an interface (router or IES or VPRN interfaces) to IGMP and PIM. The interface IGMP state will be synchronized to the backup node if it is associated with the redundant peer port. The interface can be configured to use PIM which will cause multicast streams to be sent to the elected DR only. The DR will also be the router sending traffic to the DSLAM. Since it may be required to attract traffic to both routers a flag `non-dr-attract-traffic` can be used in the PIM context to have the router ignore the DR state and attract traffic when not DR. Note that while using this flag the router may not send the stream down to the DSLAM while not DR.

When enabled, the designated router state is ignored. When disabled, **no non-dr-attract-traffic**, the designated router value is honored.

**Default** no non-dr-attract-traffic

## rpf6-table

**Syntax** **rpf6-table** {**rtable6-m** | **rtable6-u** | **both**}  
**no rpf6-table**

**Context** config>router>pim  
config>router>msdp

**Description** This command configures the sequence of route tables used to find a Reverse Path Forwarding (RPF) interface for a particular multicast route.

By default, only the unicast route table is looked up to calculate RPF interface towards the source/ rendezvous point. However the operator can specify the following:

- a) Use unicast route table only
- b) Use multicast route table only or
- c) Use both the route tables.

**Parameters** **rtable6-m** — Specifies that only the multicast route table will be used by the multicast protocol (PIM) for IPv6 RPF checks. This route table will contain routes submitted by static routes, ISIS and OSPF.

**rtable6-u** — Specifies only that the unicast route table will be used by the multicast protocol (PIM) for IPv6 RPF checks. This route table will contain routes submitted by all the unicast routing protocols.

**both** — Will always lookup first in the multicast route table and if there is a route, it will use it. If PIM does not find a route in the first lookup, it will try to find it in the unicast route table. Rtable6-m is checked before rtable6-u.

**Default** rtable-u

## sa-timeout

**Syntax** **sa-timeout** *seconds*  
**no sa-timeout**

**Context** config>router>msdp

**Description** This command configures the value for the SA entries in the cache. If these entries are not refreshed within the timeout value then they are removed from the cache. Normally the entries are refreshed at least once a minute. But under high load with many of MSDP peers the refresh cycle could be incomplete. A higher timeout value (more than 90) could be useful to prevent unstabilities in the MSDP cache.

**Default** 90

## Configuration Commands

**Parameters** *seconds* — Specifies the time, in seconds, to wait for a response from the peer before declaring the peer unavailable.

**Values** 90 — 600

### spt-switchover-threshold

**Syntax** **spt-switchover-threshold** {*grp-ip-address/mask* | *grp-ip-address netmask*} *spt-threshold*  
**no spt-switchover-threshold** {*grp-ip-address/mask* | *grp-ip-address netmask*}

**Context** config>router>pim

**Description** This command configures shortest path (SPT) tree switchover thresholds for group prefixes. PIM-SM routers with directly connected routers receive multicast traffic initially on a shared tree rooted at the Rendezvous Point (RP). Once the traffic arrives on the shared tree and the source of the traffic is known, a switchover to the SPT tree rooted at the source is attempted.

For a group that falls in the range of a prefix configured in the table, the corresponding threshold value determines when the router should switch over from the shared tree to the source specific tree. The switchover is attempted only if the traffic rate on the shared tree for the group exceeds the configured threshold.

In the absence of any matching prefix in the table, the default behavior is to switchover when the first packet is seen. In the presence of multiple prefixes matching a given group, the most specific entry is used.

**Parameters** *grp-ip-address* — The multicast group IP address expressed in dotted decimal notation.

**Values** 224.0.0.0 — 239.255.255.255

*spt-threshold* — Specifies the configured threshold in kilobits per second (kbps) for a group prefix. A switchover is attempted only if the traffic rate on the shared tree for the group exceeds this configured threshold.

**Values** 1 — 4294967294 | infinity

*mask* — The mask associated with the IP prefix expressed as a mask length or in dotted decimal notation; for example /16 for a sixteen-bit mask. The mask can also be entered in dotted decimal notation (255.255.0.0).

**Values** 4 — 32

**infinity** — When the **infinity** keyword is specified, no switchover will occur at any time, regardless of the traffic level is detected. The threshold, in kilobits per second (KBPS), value is 4294967295.

### ssm-groups

**Syntax** [**no**] **ssm-groups**

**Context** config>router>pim

**Description** This command enables the context to enable an ssm-group configuration instance.

## bootstrap-export

- Syntax** **bootstrap-export** *policy-name* [*..policy-name*]
- Context** config>router>pim>rp
- Description** Use this command to apply export policies to control the flow of bootstrap messages from the RP, and apply them to the PIM configuration. Up to 5 policy names can be specified.
- Default** no bootstrap-export
- Parameters** *policy-name* — Specify the export policy name up to 32 characters in length.

## bootstrap-import

- Syntax** **bootstrap-import** *policy-name* [*..policy-name*]
- Context** config>router>pim>rp
- Description** Use this command to apply import policies to control the flow of bootstrap messages to the RP, and apply them to the PIM configuration. Up to 5 policy names can be specified.
- Default** no bootstrap-import
- Parameters** *policy-name* — Specify the import policy name up to 32 characters in length.

## hash-mask-len

- Syntax** **hash-mask-len** *hash-mask-length*  
**no hash-mask-len**
- Context** config>router>pim>rp>bsr-candidate  
config>router>pim>rp>ipv6>bsr-candidate
- Description** This command is used to configure the length of a mask that is to be combined with the group address before the hash function is called. All groups with the same hash map to the same RP. For example, if this value is 24, only the first 24 bits of the group addresses matter. This mechanism is used to map one group or multiple groups to an RP.
- Parameters** *hash-mask-length* — The hash mask length.
- Values** 0 — 32

---

## Router Multicast Source Discovery Protocol (MSDP) Commands

### msdp

**Syntax** [no] msdp

**Context** config>router

**Description** This command enables a Multicast Source Discovery Protocol (MSDP) instance. When an MSDP instance is created, the protocol is enabled. To start or suspend execution of the MSDP protocol without affecting the configuration, use the [no] **shutdown** command.

The **no** form of the command deletes the MSDP protocol instance removing all associated configuration parameters.

**Default** no msdp

**Interactions:** In order for the MSDP protocol to function at least one peer must be configured.

When MSDP is configured and started an appropriate event message should be generated.

When **the** no form of the command is executed all sessions must be terminated and an appropriate event message should be generated.

When all peering sessions are terminated an event message per peer is not required.

### active-source-limit

**Syntax** **active-source-limit** *number*  
**no active-source-limit**

**Context** config>router>msdp  
config>router>msdp>group  
config>router>msdp>group>peer

**Description** This option controls the maximum number of active source messages that will be accepted by Multicast Source Discovery Protocol (MSDP). This effectively controls the number of active sources that can be stored on the system.

The **no** form of this command reverts the number of source message limit to default operation

**Default** No limit is placed on the number of source active records

**Parameters** *number* — This parameter defines how many active sources can be maintained by MSDP.

**Values** 0 — 1000000



## receive-msdp-msg-rate

|                      |                                                                                                                                                                                                                                                                                                                                                                                                                                                                                                                                                                                                                                                                                                                                                                                                                            |
|----------------------|----------------------------------------------------------------------------------------------------------------------------------------------------------------------------------------------------------------------------------------------------------------------------------------------------------------------------------------------------------------------------------------------------------------------------------------------------------------------------------------------------------------------------------------------------------------------------------------------------------------------------------------------------------------------------------------------------------------------------------------------------------------------------------------------------------------------------|
| <b>Syntax</b>        | <b>receive-msg-rate</b> <i>number interval seconds</i> [ <b>threshold</b> <i>number</i> ]<br><b>no receive-msg-rate</b>                                                                                                                                                                                                                                                                                                                                                                                                                                                                                                                                                                                                                                                                                                    |
| <b>Context</b>       | config>router>msdp<br>config>router>msdp>peer<br>config>router>msdp>group<br>config>router>msdp>source                                                                                                                                                                                                                                                                                                                                                                                                                                                                                                                                                                                                                                                                                                                     |
| <b>Description</b>   | This command limits the number of Multicast Source Discovery Protocol (MSDP) messages that are read from the TCP session. It is possible that an MSDP/ RP router may receive a large number of MSDP protocol message packets in a particular source active message.<br><br>The <b>no</b> form of this command reverts this active-source limit to default operation                                                                                                                                                                                                                                                                                                                                                                                                                                                        |
| <b>Default</b>       | No limit is placed on the number of MSDP and source active limit messages will be accepted.                                                                                                                                                                                                                                                                                                                                                                                                                                                                                                                                                                                                                                                                                                                                |
| <b>Parameters</b>    | <i>number</i> — Defines the number of MSDP messages (including source active messages) that are read from the TCP session per the number of seconds.<br><br><b>Values</b> 10 — 10000<br><b>Default</b> 0<br><br><i>interval seconds</i> — This defines the time that together with the <i>number</i> parameter defines the number of MSDP messages (including source active messages) that are read from the TCP session within the configured number of seconds.<br><br><b>Values</b> 1 — 600<br><b>Default</b> 0<br><br><i>threshold</i> — This number reflects the number of MSDP messages can be processed before the MSDP message rate limiting function described above is activated; this is of use in particular during at system startup and initialization.<br><br><b>Values</b> 1 — 1000000<br><b>Default</b> 0 |
| <b>Interactions:</b> | Once the number of MSDP packets (including source active messages) defined in the threshold have been processed the rate of all other MSDP packets is rate limited by no longer accepting messages from the TCP session until the time (seconds) has elapsed.                                                                                                                                                                                                                                                                                                                                                                                                                                                                                                                                                              |

## authentication-key

|                |                                                                                                                        |
|----------------|------------------------------------------------------------------------------------------------------------------------|
| <b>Syntax</b>  | <b>authentication-key</b> [ <i>authentication-key hash-key</i> ] [ <b>hash hash2</b> ]<br><b>no authentication-key</b> |
| <b>Context</b> | config>router>msdp>peer<br>config>router>msdp>group>peer                                                               |

## Configuration Commands

|                    |                                                                                                                                                                                                                                                                                                                                                                                                                                                                                                                                                                                                                                                                                                                                                                                                                                                                                                                                                                                                                                                                                                                                                             |
|--------------------|-------------------------------------------------------------------------------------------------------------------------------------------------------------------------------------------------------------------------------------------------------------------------------------------------------------------------------------------------------------------------------------------------------------------------------------------------------------------------------------------------------------------------------------------------------------------------------------------------------------------------------------------------------------------------------------------------------------------------------------------------------------------------------------------------------------------------------------------------------------------------------------------------------------------------------------------------------------------------------------------------------------------------------------------------------------------------------------------------------------------------------------------------------------|
| <b>Description</b> | This command configures a Message Digest 5 (MD5) authentication key to be used with a specific Multicast Source Discovery Protocol (MSDP) peering session. The authentication key must be configured per peer as such no global or group configuration is possible.                                                                                                                                                                                                                                                                                                                                                                                                                                                                                                                                                                                                                                                                                                                                                                                                                                                                                         |
| <b>Default</b>     | Authentication-key. All MSDP messages are accepted and the MD5 signature option authentication key is disabled.                                                                                                                                                                                                                                                                                                                                                                                                                                                                                                                                                                                                                                                                                                                                                                                                                                                                                                                                                                                                                                             |
| <b>Parameters</b>  | <p><i>authentication-key</i> — The authentication key. Allowed values are any string up to 16 characters long composed of printable, 7-bit ASCII characters. If the string contains special characters (#, \$, spaces, etc.), the entire string must be enclosed within double quotes.</p> <p><i>hash-key</i> — The hash key. The key can be any combination of ASCII characters up to 33 characters in length (encrypted). If spaces are used in the string, enclose the entire string in quotation marks (“ ”).</p> <p>This is useful when a user must configure the parameter, but, for security purposes, the actual unencrypted key value is not provided.</p> <p><b>hash</b> — Specifies the key is entered in an encrypted form. If the <b>hash</b> parameter is not used, the key is assumed to be in a non-encrypted, clear text form. For security, all keys are stored in encrypted form in the configuration file with the <b>hash</b> parameter specified.</p> <p><b>hash2</b> — Specifies the key is entered in a more complex encrypted form. If the <b>hash2</b> parameter is not used, the less encrypted <b>hash</b> form is assumed.</p> |

## data-encapsulation

|                    |                                                                                                                                                                                                                 |
|--------------------|-----------------------------------------------------------------------------------------------------------------------------------------------------------------------------------------------------------------|
| <b>Syntax</b>      | <b>[no] data-encapsulation</b>                                                                                                                                                                                  |
| <b>Context</b>     | config>router>msdp                                                                                                                                                                                              |
| <b>Description</b> | This command configures a rendezvous point (RP) using Multicast Source Discovery Protocol (MSDP) to encapsulate multicast data received in MSDP register messages inside forwarded MSDP source-active messages. |
| <b>Default</b>     | data-encapsulation                                                                                                                                                                                              |

## default-peer

|                    |                                                                                                                                                                                                                                                           |
|--------------------|-----------------------------------------------------------------------------------------------------------------------------------------------------------------------------------------------------------------------------------------------------------|
| <b>Syntax</b>      | <b>default-peer</b><br><b>no default-peer</b>                                                                                                                                                                                                             |
| <b>Context</b>     | config>router>msdp>peer<br>config>router>msdp>group>peer                                                                                                                                                                                                  |
| <b>Description</b> | Using the default peer mechanism a peer can be selected as the default Multicast Source Discovery Protocol (MSDP) peer, as a result all source-active messages from the peer will be accepted without the usual peer-reverse-path-forwarding (RPF) check. |

The MSDP peer-RPF check is different from the normal multicast RPF checks. The peer-RPF check is used to stop source-active messages from looping. A router validates source-active messages originated from other routers in a deterministic fashion.

A set of rules is applied in order to validate received source-active messages, and the first rule that applies determines the peer-RPF neighbor. All source-active messages from other routers are rejected. The rules applied to source-active messages originating at Router S received at Router R from Router N are as follows:

- If Router N and router S are one and the same, then the message is originated by a direct peer-RPF neighbor and will be accepted.
- If Router N is a configured peer, or a member of the Router R mesh group then its source-active messages are accepted.
- If Router N is the Border Gateway Protocol (BGP) next hop of the active multicast RPF route toward Router S then Router N is the peer-RPF neighbor and its source-active messages are accepted.
- If Router N is an external BGP peer of Router R and the last autonomous system (AS) number in the BGP AS-path to Router S is the same as Router N's AS number, then Router N is the peer-RPF neighbor, and its source-active messages are accepted.
- If Router N uses the same next hop as the next hop to Router S, then Router N is the peer-RPF neighbor, and its source-active messages are accepted.
- If Router N fits none of the above rules, then Router N is not a peer-RPF neighbor, and its source-active messages are rejected.

**Default** No default peer is established and all active source messages must be RPF checked.

## export

**Syntax** **export** *policy-name* [ *policy-name...*(up to 5 max)]  
**no export**

**Context** config>router>msdp  
config>router>msdp>peer  
config>router>msdp>group  
config>router>msdp>group>peer

**Description** This command specifies the policies to export source active state from the source active list into Multicast Source Discovery Protocol (MSDP).

**Default** No export policies are applied and all SA entries are announced.

**Interactions:** If multiple policy names are specified, the policies are evaluated in the order they are specified. The first policy that matches is applied. If multiple export commands are issued, the last command entered will override the previous command. A maximum of five policy names can be specified.

If you configure an export policy at the global level, each individual peer inherits the global policy. If you configure an export policy at the group level, each individual peer in a group inherits the group's policy. If you configure an export policy at the peer level then policy only applies to the peer where it is configured.

The **no** form of the command removes all policies from the configuration.

## Configuration Commands

### group

**Syntax** [no] group *group-name*

**Context** config>router>msdp

**Description** This command enables access to the context to create or modify a Multicast Source Discovery Protocol (MSDP) group. To configure multiple MSDP groups, include multiple group statements.

By default, the group's options are inherited from the global MSDP options. To override these global options, group-specific options within the group statement can be configured.

In order for a group to be of use at least one peer must be configured.

**Default** no group

**Parameters** *group-name* — Specifies a unique name for the MSDP group.

**Interactions:** If the group name provided is already configured then this command only provides the context to configure the options pertaining to this group.

If the group name provided is not already configured, then the group name must be created and the context to configure the parameters pertaining to the group should be provided. In this case the \$ prompt to indicate that a new entity (group) is being created should be used.

### import

**Syntax** import *policy-name* [ *policy-name...*(up to 5 max)]  
no import

**Context** config>router>msdp  
config>router>msdp>peer  
config>router>msdp>group  
config>router>msdp>group>peer

**Description** This command specifies the policies to import source active state from Multicast Source Discovery Protocol (MSDP) into source active list.

**Default** No import policies are applied and all source active messages are allowed.

**Interactions:** If multiple policy names are specified, the policies are evaluated in the order they are specified. The first policy that matches is applied. If multiple import commands are issued, the last command entered will override the previous command. A maximum of five policy names can be specified.

The no form of the command removes all policies from the configuration.

If you configure an import policy at the global level, each individual peer inherits the global policy.

If you configure an import policy at the group level, each individual peer in a group inherits the group's policy.

If you configure an import policy at the peer level then policy only applies to the peer where it is configured.

## local-address

|                      |                                                                                                                                                                                                                                                                                                                                                                                                                                                                                                                                                                                                                                                                                                                      |
|----------------------|----------------------------------------------------------------------------------------------------------------------------------------------------------------------------------------------------------------------------------------------------------------------------------------------------------------------------------------------------------------------------------------------------------------------------------------------------------------------------------------------------------------------------------------------------------------------------------------------------------------------------------------------------------------------------------------------------------------------|
| <b>Syntax</b>        | <b>local-address</b> <i>address</i><br><b>no local-address</b>                                                                                                                                                                                                                                                                                                                                                                                                                                                                                                                                                                                                                                                       |
| <b>Context</b>       | config>router>msdp<br>config>router>msdp>peer<br>config>router>msdp>group<br>config>router>msdp>group>peer                                                                                                                                                                                                                                                                                                                                                                                                                                                                                                                                                                                                           |
| <b>Description</b>   | <p>This command configures the local end of a Multicast Source Discovery Protocol (MSDP) session. In order for MSDP to function at least one peer must be configured. When configuring a peer, you must include this local-address command to configure the local end of the MSDP session. This address must be present on the node and is used to validate incoming connections to the peer and to establish connections to the remote peer.</p> <p>The no local address format of this command removes the local-address from the configuration.</p>                                                                                                                                                               |
| <b>Default</b>       | No local address is configured.                                                                                                                                                                                                                                                                                                                                                                                                                                                                                                                                                                                                                                                                                      |
| <b>Parameters</b>    | <i>address</i> — Specifies an existing address on the node.                                                                                                                                                                                                                                                                                                                                                                                                                                                                                                                                                                                                                                                          |
| <b>Interactions:</b> | <p>If the user enters this command then the address provided is validated and will be used as the local address for MSDP peers from that point. If a subsequent local-address command is entered it will replace the existing configuration and existing session(s) will be terminated.</p> <p>Similarly when the no form of this command is entered the existing local-address will be removed from the configuration and the existing session(s) will be terminated.</p> <p>Whenever a session is terminated all information pertaining to and learned from that peer and will be removed.</p> <p>Whenever a new peering session is created or a peering session is lost an event message should be generated.</p> |

## mode

|                    |                                                                                                                                                                                                                                                                                                                                                 |
|--------------------|-------------------------------------------------------------------------------------------------------------------------------------------------------------------------------------------------------------------------------------------------------------------------------------------------------------------------------------------------|
| <b>Syntax</b>      | <b>mode</b> { <b>mesh-group</b>   <b>standard</b> }                                                                                                                                                                                                                                                                                             |
| <b>Context</b>     | config>router>msdp>group                                                                                                                                                                                                                                                                                                                        |
| <b>Description</b> | <p>This command configures groups of peers in a full mesh topology to limit excessive flooding of source-active messages to neighboring peers.</p> <p>Multicast Source Discovery Protocol (MSDP) peers can be configured grouped in a full-mesh topology that prevents excessive flooding of source-active messages to neighboring peers.</p>   |
| <b>Default</b>     | standard (non-meshed)                                                                                                                                                                                                                                                                                                                           |
| <b>Parameters</b>  | <p><b>mesh-group</b> — Specifies that source-active message received from a mesh group member are always accepted but are not flooded to other members of the same mesh group. These source-active messages are only flooded to non-mesh group peers or members of other mesh groups.</p> <p><b>standard</b> — Specifies a non-meshed mode.</p> |

## Configuration Commands

**Interactions:** In a meshed configuration all members of the group must have a peer connection with every other mesh group member. If this rule is not adhered to then unpredictable results may occur.

### peer

**Syntax** [no] peer *peer-address*

**Context** config>router>msdp  
config>router>msdp>group

**Description** This command configures peer parameters. Multicast Source Discovery Protocol (MSDP) must have at least one peer configured. A peer is defined by configuring a local-address that can be used by this node to set up a peering session and the address of a remote MSDP router. It is the address of this remote peer that is configured in this command and it identifies the remote MSDP router address.

After peer relationships are established, the MSDP peers exchange messages to advertise active multicast sources. It may be required to have multiple peering sessions in which case multiple peer statements should be included in the configurations.

By default the options applied to a peer are inherited from the global or group-level. To override these inherited options, include peer-specific options within the peer statement.

At least one peer must be configured for MSDP to function.

**Default** none

**Parameters** *peer-address* — The address configured in this statement must identify the remote MSDP router that the peering session must be established with.

**Interactions:** If the peer address provided is already a configured peer then this command only provides the context to configure the parameters pertaining to this peer.

If the peer address provided is not already a configured peer, then the peer instance must be created and the context to configure the parameters pertaining to this peer should be provided. In this case the \$ prompt to indicate that a new entity (peer) is being created should be used.

The peer address provided will be validated and assuming it is valid it will be used as the remote address for an MSDP peering session. When the no form of this command is entered the existing peering address will be removed from the configuration and the existing session will be terminated. Whenever a session is terminated all source active information pertaining to and learned from that peer and will be removed. Whenever a new peering session is created or a peering session is lost an event message should be generated.

### SOURCE

**Syntax** [no] source *ip-prefix/mask*

**Context** config>router>msdp

**Description** This command limits the number of active source messages the router accepts from sources in the specified address range.

The **no** form of this message removes the source active rate limiter for this source address range.

**Default**

None. The source active **msdp** messages are not rate limited based on the source address range.

**Interactions:**

If the prefix and mask provided is already a configured then this command only provides the context to configure the parameters pertaining to this active source-message filter.

If the prefix and mask provided is not already a configured, then the source node instance must be created and the context to configure the parameters pertaining to this node should be provided. In this case the \$ prompt to indicate that a new entity (source) is being created should be used.

**Parameters**

*ip-prefix* — The IP prefix in dotted decimal notation for the range used by the ABR to advertise that summarizes the area into another area.

**Values**      ip-prefix/mask:                  ip-prefix a.b.c.d (host bits must be 0)

*mask* — The subnet mask for the range expressed as a decimal integer mask length or in dotted decimal notation.

**Values**      0 — 32 (mask length), 0.0.0.0 — 255.255.255.255 (dotted decimal)

---

## Multicast CAC Policy Configuration Commands

### mcac

|                    |                                                                         |
|--------------------|-------------------------------------------------------------------------|
| <b>Parameters</b>  | <b>mcac</b>                                                             |
| <b>Context</b>     | config>router<br>config>router>pim>if                                   |
| <b>Description</b> | This command enables the context to configure multicast CAC parameters. |
| <b>Default</b>     | none                                                                    |

### policy

|                    |                                                                                                                                                                                                                                                                                                                                                                                                                                                                                                                                                                                                                                                               |
|--------------------|---------------------------------------------------------------------------------------------------------------------------------------------------------------------------------------------------------------------------------------------------------------------------------------------------------------------------------------------------------------------------------------------------------------------------------------------------------------------------------------------------------------------------------------------------------------------------------------------------------------------------------------------------------------|
| <b>Syntax</b>      | <b>policy</b> <i>mcac-policy-name</i><br><b>no policy</b> <i>mcac-policy-name</i>                                                                                                                                                                                                                                                                                                                                                                                                                                                                                                                                                                             |
| <b>Context</b>     | configure>router>igmp>interface>mcac<br>configure>service>vprn>igmp>interface >mcac                                                                                                                                                                                                                                                                                                                                                                                                                                                                                                                                                                           |
| <b>Description</b> | This command references the global channel bandwidth definition policy that is used for (H)mcac and HQoS Adjust.<br><br>HQoS Adjustment is supported only with redirection enabled. In other words, the policy from the redirected interface is used for HQoS Adjustment.<br><br>Hierarchical mcac (Hmcac) is supported only with redirection enabled. In Hmcac, the subscriber is checked first against its bandwidth limits followed by the check on the redirected interface against the bandwidth limits defined under the redirected interface. In the Hmcac case the channel definition policy must be referenced under the redirected interface level. |
| <b>Parameters</b>  | <i>mcac-policy-name</i> — Specifies the name of the global mcac channel definition policy defined under the hierarchy configure>router>mcac>policy.                                                                                                                                                                                                                                                                                                                                                                                                                                                                                                           |
| <b>Default</b>     | No policy is referenced.                                                                                                                                                                                                                                                                                                                                                                                                                                                                                                                                                                                                                                      |

### bundle

|                    |                                                                                                                                                                                                                                                                                      |
|--------------------|--------------------------------------------------------------------------------------------------------------------------------------------------------------------------------------------------------------------------------------------------------------------------------------|
| <b>Parameters</b>  | <b>[no] bundle</b> <i>bundle-name</i>                                                                                                                                                                                                                                                |
| <b>Context</b>     | config>router>mcac>policy                                                                                                                                                                                                                                                            |
| <b>Description</b> | This command creates the context that enables the grouping of MCAC group addresses into bundles.<br><br>When a number of multicast groups or BTV channels are grouped into a single bundle, then policing, if a join for a particular MC-group (BTV channel), can depend on whether: |



1. There is enough physical bandwidth on the egress interface.
2. The given channel is a mandatory or optional channel.
  - If optional, is there sufficient bandwidth according to the policy settings for the relevant interface.
  - If optional, is there sufficient bandwidth within the bundle.

The **no** form of the command removes the named bundle from the configuration.

**Default** none

**Parameters** *bundle-name* — Specifies the multicast bundle name. Allowed values are any string up to 32 characters long composed of printable, 7-bit ASCII characters. If the string contains special characters (#, \$, spaces, etc.), the entire string must be enclosed within double quotes.

**bw** *bandwidth* — Defines the bandwidth available to this bundle when unconstrained.

## bandwidth

**Syntax** **bandwidth** *bandwidth*  
**no bandwidth**

**Context** config>router>mcac>policy>bundle

**Description** This command configures the MCAC policy bundle maximum bandwidth.

**Parameters** *bandwidth* — Specifies the MCAC policy bandwidth.

## channel

**Parameters** **channel** *start-address end-address* **bw** *bandwidth* [**class** {**high** | **low**}] [**type** {**mandatory** | **optional**}]  
**no channel** **mc-ip-addr** *mc-ip-addr*

**Context** config>router>mcac>policy>bundle

**Description** This command creates a MC group (range) as a channel within the bundle where it is configured. A join for a particular MC group address (BTV channel) can be accepted depending on:

- 1) The channel is mandatory :

If there is sufficient bandwidth according to the policy settings for the interface. For bundle level, there is no need for a check since all the mandatory channels get bandwidth pre-reserved when created.

- 2) The channel is optional:

If there is sufficient bandwidth according to the policy settings for the interface.

If there is sufficient bandwidth inside the bundle.

## Configuration Commands

When the multicast address is already specified in the same bundle then the new entry overwrites the old. If a multicast address is already specified in another bundle then this command will be rejected and an error message is generated.

If the bundle is removed, the policies associated are also removed and every multicast group that was previously policed (because it was in the bundle that contained the policy) becomes free of constraints.

When a new bundle policy is added to a MCAC policy then policing of these new addresses must be in a gradual fashion. No active multicast groups can be removed. When a leave message is received for an optional channel then the multicast stream should be pruned and subsequent new joins can be denied in accordance to the policy.

It is possible that momentarily there may be insufficient bandwidth, even for mandatory channels, in this bundle.

**Default** none

**Parameters** *start-address end-address* — Specifies the beginning and ending multicast IP addresses that identifies a multicast stream (BTV channel).

In a source-specific multicast (SSM) application, a source address preceded by a multicast address is used to identify a specific stream. If a source address is specified then the multicast address must be within the configured SSM address range.

**bw bandwidth** — Specifies the bandwidth required by this channel in kbps.

If this bandwidth is configured for a mandatory channel then this bandwidth is reserved by subtracting the amount from the total available bandwidth for all potential egress interfaces and the bundle.

If this bandwidth is configured as an optional channel then this bandwidth must be available for both the bundle and the egress interface requesting the channel to be added. Once the channel has been added the available bandwidth for the bundle and the interface must be reduced by the configured bandwidth of channel.

**Values** 10 — 20000 kbps

**class {high | low}** — Provides deeper classification of channels used in the algorithm when LAG ports change state.

**Default** low

**type {mandatory | optional}** — Specifies the channel to be either mandatory or optional.

- **mandatory** — When the **mandatory** keyword is specified, then the bandwidth is reserved by subtracting it from the total available for all the potential egress interfaces and the bundle.
- **optional** — When the **optional** keyword is specified then the bandwidth must be available on both the bundle and the egress interface that requests the channel to be added. Once the channel has been added the available bandwidth for the bundle and the interface must be reduced by the configured bandwidth of channel.

**Default** optional

**mc-ip-address mc-ip-address** — Specifies the IP address that identifies a multicast stream (BTV channel). This must be a multicast address in the x.x.x.x format.

In the case of an SSM application, this means a source address preceded by a multicast address to identify a specific stream in the y.y.y/x.x.x.x format. If a source address is specified, then the multicast address must be within the configured SSM address range.

## mc-constraints

**Parameters** **mc-constraints**

**Context** config>router>mcac>policy>bundle

**Description** This command enables the context to configure the level and its associated bandwidth for a bundle or a logical interface.

**Default** none

## lag-port-down

**Parameters** **lag-port-down** *lag-id* **number-down** *number-lag-port-down* **level** *level-id*  
**no lag-port-down** *lag-id* **number-down** *number-lag-port-down*

**Context** config>router>mcac>policy>bundle>mc-constraints

**Description** This command configures the bandwidth available both at the interface and bundle level when a specific number of ports in a LAG group fail.

**Default** none

**Parameters** *lag-id* — When the number of ports available in the LAG link is reduced by the number of ports configured in this context then the *level-id* specified here must be applied.

**number-down** *number-lag-port-down* — If the number of ports available in the LAG is reduced by the number of ports configured in this command here then bandwidth allowed for bundle and/or interface will be as per the levels configured in this context.

**level** *level-id* — Specifies the amount of bandwidth available within a given bundle for MC traffic for a specified level.

## number-down

**Parameters** **number-down** *number-lag-port-down* **level** *level-id*  
**no number-down** *number-lag-port-down*

**Context** config>router>pim>if>mcac>mc-constraints

**Description** This command configures the number of ports down along with level for multicast cac policy on this interface.

**Default** none

**Parameters** **number-down** *number-lag-port-down* — If the number of ports available in the LAG is reduced by the number of ports configured in this command here then bandwidth allowed for bundle and/or interface will be as per the levels configured in this context.

**level** *level-id* — Specifies the amount of bandwidth available within a given bundle for MC traffic for a specified level.

## level

**Parameters** **level** *level* **bw** *bandwidth*  
**no level** *level*

**Context** config>router>mcac>policy>bundle>mc-constraints

**Description** This command configures the amount of bandwidth available within a given bundle for MC traffic for a specified level. The amount of allowable BW for the specified level is expressed in kbps and this can be defined for up to eight different levels.

The **no** form of the command removes the level from the configuration.

**Default** none (If no bandwidth is defined for a given level then no limit is applied.)

**Parameters** *level* — Specifies the bandwidth for a given level. Level 1 has the highest priority. Level 8 has the lowest priority.

**Values** 1 — 8

**bw** *bandwidth* — Specifies the bandwidth, in kbps, for the level.

**Values** 1 — 2147483647 kbps

**Default** 1

## number-down

**Syntax** **number-down** *number-lag-port-down* **level** *level-id*  
**no number-down** *number-lag-port-down*

**Context** config>router>igmp>mcac>mc-constraints

|                    |                                                                                                                                                                     |
|--------------------|---------------------------------------------------------------------------------------------------------------------------------------------------------------------|
| <b>Description</b> | This command configures the number of ports down along with level for the MCAC policy.                                                                              |
| <b>Parameters</b>  | <i>number-lag-port-down</i> — Specifies the number of ports down along with level for the MCAC policy.<br><b>Values</b> 1 — 8                                       |
|                    | <b>level</b> <i>level-id</i> — Specifies the bandwidth for a given level. Level 1 has the highest priority. Level 8 has the lowest priority.<br><b>Values</b> 1 — 8 |

## unconstrained-bw

|                    |                                                                                                                                                                                                                                                                                                                                                                                                                                                                                                                                                                                                                                                                                                                                                                                                                                                                        |
|--------------------|------------------------------------------------------------------------------------------------------------------------------------------------------------------------------------------------------------------------------------------------------------------------------------------------------------------------------------------------------------------------------------------------------------------------------------------------------------------------------------------------------------------------------------------------------------------------------------------------------------------------------------------------------------------------------------------------------------------------------------------------------------------------------------------------------------------------------------------------------------------------|
| <b>Syntax</b>      | <b>unconstrained-bw</b> <i>bandwidth</i> <b>mandatory-bw</b> <i>mandatory-bw</i><br><b>no unconstrained-bw</b>                                                                                                                                                                                                                                                                                                                                                                                                                                                                                                                                                                                                                                                                                                                                                         |
| <b>Context</b>     | <b>configure&gt;router&gt;igmp&gt;interface&gt;mcac</b><br><b>configure&gt;service&gt;vprn&gt;igmp&gt;interface &gt;mcac</b>                                                                                                                                                                                                                                                                                                                                                                                                                                                                                                                                                                                                                                                                                                                                           |
| <b>Description</b> | This command enables Mcac (or Hmcac) function on the corresponding level (subscriber, or redirected interface). When Mcac (or Hmcac) is enabled and a channel definition policy is referenced, admission control is performed. The allocated bandwidth for optional channels should not exceed the unconstrained-bw minus the mandatory-bw. The mandatory channels have to stay below the specified value for the mandatory-bw. After this check, the bundle checks are performed.<br><br>Hierarchical mcac (Hmcac) is supported only with redirection enabled. In Hmcac, the subscriber is checked first against its bandwidth limits followed by the check on the redirected interface against the bandwidth limits defined under the redirected interface. In the Hmcac case the channel definition policy must be referenced under the redirected interface level. |
| <b>Parameters</b>  | <i>bandwidth</i> — Specifies the unconstrained bandwidth in kbps for the MCAC policy.<br><b>mandatory-bw</b> <i>mandatory-bw</i> — Specifies the mandatory bandwidth in kbps for the MCAC policy.                                                                                                                                                                                                                                                                                                                                                                                                                                                                                                                                                                                                                                                                      |

## default-action

|                    |                                                                                                                                                                                                                                                                                          |
|--------------------|------------------------------------------------------------------------------------------------------------------------------------------------------------------------------------------------------------------------------------------------------------------------------------------|
| <b>Parameters</b>  | <b>default-action</b> { <b>accept</b>   <b>discard</b> }                                                                                                                                                                                                                                 |
| <b>Context</b>     | config>router>mcac>policy                                                                                                                                                                                                                                                                |
| <b>Description</b> | This command specifies the action to be applied to multicast streams (channels) when the streams do not match any of the multicast addresses defined in the MCAC policy.<br><br>When multiple default-action commands are entered, the last command will overwrite the previous command. |
| <b>Default</b>     | discard (all multicast stream not defined in a MCAC policy will be discarded)                                                                                                                                                                                                            |
| <b>Parameters</b>  | <b>accept</b> — Specifies multicast streams (channels) not defined in the MCAC policy will be accepted.<br><b>discard</b> — Specifies multicast streams (channels) not defined in the MCAC policy will be dropped.                                                                       |

### shutdown

**Parameters** [no] shutdown

**Context** config>router>mcac>policy>bundle

**Description** This command administratively disables the entity. When disabled, an entity does not change, reset, or remove any configuration settings or statistics. Many entities must be explicitly enabled using the **no shutdown** command.

When an entity is shutdown, the operational state of the entity is disabled as well as the operational state of any entities contained within. Many objects must be shutdown before they may be deleted.

Unlike other commands and parameters where the default state is not indicated in the configuration file, shutdown and no shutdown are always indicated in system generated configuration files.

The **no** form of the command puts an entity into the administratively enabled state.

When a shutdown is performed then all constraints placed on either a bundle or an interface are removed and multicast can potentially take up the full bandwidth of the interface. Furthermore, when a **no shutdown** command is executed then policing of the policy must be in a gradual fashion. No active multicast groups may be removed. When a leave message is received for an optional channel then the multicast stream should be pruned and subsequent new joins can be denied in accordance with the policy. This may mean that for a period of time insufficient bandwidth is available even for mandatory channels.

---

## MLD Commands

### mld

**Syntax** [no] mld

**Context** config>router

**Description** This command enables the context to configure Multicast Listener Discovery (MLD) parameters. The **no** form of the command disables MLD.

**Default** no mld

### interface

**Syntax** [no] interface *ip-int-name*

**Context** config>router>mld

**Description** This command enables the context to configure an Multicast Listener Discovery (MLD) interface. The interface is a local identifier of the network interface on which reception of the specified multicast address is to be enabled or disabled.

The **no** form of the command deletes the MLD interface. The **shutdown** command in the **config>router>mld>interface** context can be used to disable an interface without removing the configuration for the interface.

**Default** **no interface** — No interfaces are defined.

**Parameters** *ip-int-name* — The IP interface name. Interface names must be unique within the group of defined IP interfaces for **config router interface** and **config service ies interface** commands. An interface name cannot be in the form of an IP address. Interface names can be any string up to 32 characters long composed of printable, 7-bit ASCII characters. If the string contains special characters (#, \$, spaces, etc.), the entire string must be enclosed within double quotes.

If the IP interface name does not exist or does not have an IP address configured an error message will be returned.

If the IP interface exists in a different area it will be moved to this area.

### import

**Syntax** **import** *policy-name*  
**no import**

**Context** config>router>mld>if

## Configuration Commands

|                    |                                                                                                                                                                                                                                                                                                                                                                                                  |
|--------------------|--------------------------------------------------------------------------------------------------------------------------------------------------------------------------------------------------------------------------------------------------------------------------------------------------------------------------------------------------------------------------------------------------|
| <b>Description</b> | This command specifies the import route policy to be used for determining which membership reports are accepted by the router. Route policies are configured in the <b>config&gt;router&gt;policy-options</b> context.<br>When an import policy is not specified, all the IGMP reports are accepted.<br>The <b>no</b> form of the command removes the policy association from the IGMP instance. |
| <b>Default</b>     | <b>no import</b> — No import policy specified.                                                                                                                                                                                                                                                                                                                                                   |
| <b>Parameters</b>  | <i>policy-name</i> — The route policy name. Allowed values are any string up to 32 characters long composed of printable, 7-bit ASCII characters. If the string contains special characters (#, \$, spaces, etc.), the entire string must be enclosed within double quotes. Route policies are configured in the <b>config&gt;router&gt;policy-options</b> context.                              |

## max-groups

|                    |                                                                                                                                                                                                                                                                                                                                                                 |
|--------------------|-----------------------------------------------------------------------------------------------------------------------------------------------------------------------------------------------------------------------------------------------------------------------------------------------------------------------------------------------------------------|
| <b>Syntax</b>      | <b>max-groups</b> <i>value</i><br><b>no max-groups</b>                                                                                                                                                                                                                                                                                                          |
| <b>Context</b>     | config>router>mld>if                                                                                                                                                                                                                                                                                                                                            |
| <b>Description</b> | This command specifies the maximum number of groups for which MLD can have local receiver information based on received MLD reports on this interface. When this configuration is changed dynamically to a value lower than the currently accepted number of groups, the groups that are already accepted are not deleted. Only new groups will not be allowed. |
| <b>Default</b>     | 0, no limit to the number of groups.                                                                                                                                                                                                                                                                                                                            |
| <b>Parameters</b>  | <i>value</i> — Specifies the maximum number of groups for this interface.<br><b>Values</b> 1 — 16000                                                                                                                                                                                                                                                            |

## query-interval

|                    |                                                                                                                                                                                                                                      |
|--------------------|--------------------------------------------------------------------------------------------------------------------------------------------------------------------------------------------------------------------------------------|
| <b>Syntax</b>      | <b>query-interval</b> <i>seconds</i><br><b>no query-interval</b>                                                                                                                                                                     |
| <b>Context</b>     | config>router>mld<br>config>router>mld>if                                                                                                                                                                                            |
| <b>Description</b> | This command specifies the frequency that the querier router transmits general host-query messages. The host-query messages solicit group membership information and are sent to the all-systems multicast group address, 224.0.0.1. |
| <b>Default</b>     | 125                                                                                                                                                                                                                                  |
| <b>Parameters</b>  | <i>seconds</i> — The time frequency, in seconds, that the router transmits general host-query messages.<br><b>Values</b> 2 — 1024                                                                                                    |



## query-last-member-interval

|                    |                                                                                                                                                                                                                                                         |
|--------------------|---------------------------------------------------------------------------------------------------------------------------------------------------------------------------------------------------------------------------------------------------------|
| <b>Syntax</b>      | <b>query-last-member-interval</b> <i>seconds</i>                                                                                                                                                                                                        |
| <b>Context</b>     | config>router>mld<br>config>router>mld>if                                                                                                                                                                                                               |
| <b>Description</b> | This command configures the frequency at which the querier sends group-specific query messages including messages sent in response to leave-group messages. The lower the interval, the faster the detection of the loss of the last member of a group. |
| <b>Default</b>     | 1                                                                                                                                                                                                                                                       |
| <b>Parameters</b>  | <i>seconds</i> — Specifies the frequency, in seconds, at which query messages are sent.                                                                                                                                                                 |
|                    | <b>Values</b> 1 — 1024                                                                                                                                                                                                                                  |

## query-response-interval

|                    |                                                                                                                          |
|--------------------|--------------------------------------------------------------------------------------------------------------------------|
| <b>Syntax</b>      | <b>query-response-interval</b> <i>seconds</i>                                                                            |
| <b>Context</b>     | config>router>mld<br>config>router>mld>if                                                                                |
| <b>Description</b> | This command specifies how long the querier router waits to receive a response to a host-query message from a host.      |
| <b>Default</b>     | 10                                                                                                                       |
| <b>Parameters</b>  | <i>seconds</i> — Specifies the the length of time to wait to receive a response to the host-query message from the host. |
|                    | <b>Values</b> 1 — 1023                                                                                                   |

## static

|                    |                                                                                                                                                                                          |
|--------------------|------------------------------------------------------------------------------------------------------------------------------------------------------------------------------------------|
| <b>Syntax</b>      | <b>static</b>                                                                                                                                                                            |
| <b>Context</b>     | config>router>mld>if                                                                                                                                                                     |
| <b>Description</b> | This command tests multicast forwarding on an interface without a receiver host. When enabled, data is forwarded to an interface without receiving membership reports from host members. |
| <b>Default</b>     | none                                                                                                                                                                                     |

## Configuration Commands

### group

**Syntax** [no] group *ipv6-address*

**Context** config>router>mld>if>static

**Description** This command enables the context to add a static multicast group either as a (\*,G) or one or more (S,G) records. Use IGMP static group memberships to test multicast forwarding without a receiver host. When IGMP static groups are enabled, data is forwarded to an interface without receiving membership reports from host members.

When static IGMP group entries on point-to-point links that connect routers to a rendezvous point (RP) are configured, the static IGMP group entries do not generate join messages toward the RP.

The **no** form of the command removes the IPv6 address from the configuration.

**Default** none

**Parameters** *ipv6-address* — Specifies an IGMP multicast group address that receives data on an interface. The IP address must be unique for each static group.

### SOURCE

**Syntax** [no] source *ipv6-address*

**Context** config>router>mld>if>static>group  
config>router>mld>ssm-translate>grp-range

**Description** This command specifies an IPv6 unicast address that sends data on an interface. This enables a multicast receiver host to signal a router the group to receive multicast traffic from, and from the source(s) that the traffic is expected.

The **source** command is mutually exclusive with the specification of individual sources for the same group.

The source command, in combination with the group, is used to create a specific (S,G) static group entry.

The **no** form of the command removes the source from the configuration.

**Default** none

**Parameters** *ip-address* — Specifies the IPv6 unicast address.

### starg

**Syntax** [no] starg

**Context** config>router>mld>if>static>group

**Description** This command adds a static (\*,G) entry. This command can only be enabled if no existing source addresses for this group are specified.

Use the **no** form of the command to remove the starg entry from the configuration.

**Default** none

## subnet-check

**Syntax** **[no] subnet-check**

**Context** config>router>mld>interface

**Description** This command enables subnet checking for MLD messages received on this interface. All MLD packets with a source address that is not in the local subnet are dropped.

**Default** enabled

## version

**Syntax** **version** *version*  
**no version**

**Context** config>router>mld>if

**Description** This command specifies the MLD version. If routers run different versions, they will negotiate the lowest common version of MLD that is supported by hosts on their subnet and operate in that version. For MLD to function correctly, all routers on a LAN should be configured to run the same version of MLD on that LAN.

**Default** 1

**Parameters** *version* — Specifies the MLD version number.

**Values** 1, 2

## robust-count

**Syntax** **robust-count** *robust-count*  
**no robust-count**

**Context** config>router>mld

**Description** This command configures the robust count. The robust-count variable allows tuning for the expected packet loss on a subnet. If a subnet anticipates losses, the robust-count variable can be increased.

**Default** 2

**Parameters** *robust-count* — Specify the robust count value.

**Values** 2 — 10

### ssm-translate

**Syntax** **ssm-translate**

**Context** config>router>mld

**Description** This command enables the context to configure group ranges which are translated to SSM (S,G) entries. If the static entry needs to be created, it has to be translated from a IGMPv1 IGMPv2 request to a Source Specific Multicast (SSM) join. An SSM translate source can only be added if the starg command is not enabled. An error message is generated if you try to configure the **source** command with **starg** command enabled.

### grp-range

**Syntax** [**no**] **grp-range** *start end*

**Context** config>router>mld>ssm-translate

**Description** This command is used to configure group ranges which are translated to SSM (S,G) entries.

**Parameters** *start* — An IP address that specifies the start of the group range.  
*end* — An IP address that specifies the end of the group range. This value should always be greater than or equal to the value of the *start* value.

### source

**Syntax** [**no**] **source** *ip-address*

**Context** config>router>mld>ssm-translate>grp-range

**Description** This command specifies the source IP address for the group range. Whenever a (\*,G) report is received in the range specified by **grp-range** *start* and *end* parameters, it is translated to an (S,G) report with the value of this object as the source address.

**Parameters** *ip-address* — Specifies the IP address that will be sending data.

---

## Operational Commands

### mrinfo

**Syntax** `mrinfo ip-address [router router-name|service]`

**Context** <GLOBAL>

**Description** This command is used to display relevant multicast information from the target multicast router. Information displayed includes adjacency information, protocol, metrics, thresholds, and flags from the target multicast router. This information can be used by network operators to determine whether bi-directional adjacencies exist.

**Parameters** *ip-address* — Specify the IP address of the multicast capable target router should be entered.

**router** *router-name* — Specify the router instance that this command applies to.

**Default** management Base

*service* — Specify the service instance that this command applies to.

**Values** 1 — 2147483647

**Mrinfo Output Fields** — The following table describes the output fields:

| Label           | Description                                        |
|-----------------|----------------------------------------------------|
| General flags   |                                                    |
| version         | Indicates software version on queried router.      |
| prune           | Indicates that router understands pruning.         |
| genid           | Indicates that router sends generation IDs.        |
| mtrace          | Indicates that the router handles mtrace requests. |
| Neighbors flags |                                                    |
| 1               | Metric                                             |
| 0               | Threshold (multicast time-to-live)                 |
| pim             | PIM enabled on interface.                          |
| down            | Operational status of interface.                   |
| disabled        | Administrative status of interface.                |
| leaf            | No downstream neighbors on interface.              |
| querier         | Interface is IGMP querier.                         |
| tunnel          | Neighbor reached via tunnel.                       |

## Configuration Commands

```
A:dut-f# mrimfo 10.1.1.2

10.1.1.2 [version 3.0,prune,genid,mtrace]:
 10.1.1.2 -> 10.1.1.1 [1/0/pim]
 16.1.1.1 -> 0.0.0.0 [1/0/pim/down/disabled]
 17.1.1.1 -> 0.0.0.0 [1/0/pim/querier/leaf]
 200.200.200.3 -> 200.200.200.5 [1/0/tunnel/pim]...
```

## mstat

**Syntax** **mstat source** *ip-address* **group** *grp-ip-address* [**destination** *dst-ip-address*] [**hop** *hop*] [**router** *router-name*]**[service]** [**wait-time** *wait-time*]

**Context** <GLOBAL>

**Description** This command traces a multicast path from a source to a receiver and displays multicast packet rate and loss information. The **mstat** command adds the capability to show the multicast path in a limited graphic display and provide drops, duplicates, TTLs, and delays at each node. This information is useful to network operators because it identifies nodes with high drop and duplicate counts. Duplicate counts are shown as negative drops.

**Parameters** **source** *ip-address* — Specify the IP address of the multicast-capable source. This is a unicast address of the beginning of the path to be traced.

**group** *group-ip-address* — Specify the multicast address that will be used.

**destination** *dst-ip-address* — Specify the IP address of the unicast destination. If this parameter is omitted, the IP address of the system where the command is entered is used. The destination parameter can also be used to specify a local interface address as the destination address to send the trace query.

**Default** The default address for the destination address is the incoming IETF format for that (S,G)

**hop** *hop* — Specify the maximum number of hops that will be traced from the receiver back toward the source.

**Values** 1 — 255

**Default** **32 hops** (infinity for the DVMRP routing protocol).

**router** *router-name* — Specify the router instance that this command applies to.

*service* — Specify the service instance that this command applies to.

**Values** 1 — 2147483647

**wait-time** *wait-time* — Specify the number of seconds to wait for the response.

**Values** 1 — 60

**Default** 10

**Mstat Output Fields** — The following table describes the output fields:

| <b>Label</b>    | <b>Description</b>                                                                                                    |
|-----------------|-----------------------------------------------------------------------------------------------------------------------|
| hop             | Number of hops from the source to the listed router.                                                                  |
| router name     | Name of the router for this hop or “?” when not reverse DNS translated.                                               |
| address         | Address of the router for this hop.                                                                                   |
| protocol        | Protocol used.                                                                                                        |
| ttl             | Forward TTL threshold. TTL that a packet is required to have before it will be forwarded over the outgoing interface. |
| forwarding code | Forwarding information/error code for this hop.                                                                       |

For each interface between 2 nodes a line is printed, following the same layout as other routers with an implementation derived from mroute. Note the following:

- The forwarding information/error code is only displayed when different from “No Error”.
- “?” means the there is no reverse DNS translation.
- There is no “Overall Mcast Pkt Rate” available in the PE for the VPRN case.

## Configuration Commands

```

Source Response Dest Overall Packet Statistics For Traffic From
10.10.16.9 10.20.1.6 Mcast Pkt 10.10.16.9 To 224.5.6.7
| ___/ rtt 29 ms Rate
v /
10.10.16.3
10.10.2.3 ?
| ^ ttl 2 1 pps 0/0 = -- 0 pps
v |
10.10.2.1
10.10.1.1 ?
| ^ ttl 3 0 pps 0/0 = -- 0 pps
v |
10.10.1.2
10.10.4.2 ? Reached RP/Core
| ^ ttl 4 0 pps 0/0 = -- 0 pps
v |
10.10.4.4
10.10.6.4 ?
| ^ ttl 5 0 pps 0/0 = -- 0 pps
v |
10.10.6.5
10.10.10.5 ?
| ___ ttl 6 0 pps 0/0 = -- 0 pps
v \
10.10.10.6 10.20.1.6
Receiver Query Source

```

## mtrace

**Syntax** **mtrace source** *ip-address* **group** *grp-ip-address* [**destination** *dst-ip-address*] [**hop** *hop*] [**router** *router-name|service*] [**wait-time** *wait-time*]

**Context** <GLOBAL>

**Description** This command traces the multicast path from a source to a receiver by passing a trace query hop-by-hop along the reverse path from the receiver to the source. At each hop, information such as the hop address, routing error conditions, and packet statistics are gathered and returned to the requestor. A network administrator can determine where multicast flows stop and verify the flow of the multicast stream.

**Parameters** **source** *ip-address* — Specify the IP address of the multicast-capable source. This is a unicast address of the beginning of the path to be traced.

**group** *group-ip-address* — Specify the multicast address that will be used.

**destination** *dst-ip-address* — Specify the IP address of the unicast destination. If this parameter is omitted, the IP address of the system where the command is entered is used. The destination parameter can also be used to specify a local interface address as the destination address to send the trace query.

**Default** The default address for the destination address is the incoming IETF format for that (S,G)



**hop** *hop* — Specify the maximum number of hops that will be traced from the receiver back toward the source.

**Values** 1 — 255

**Default** 32 hops (infinity for the DVMRP routing protocol).

**router** *router-name* — Specify the router instance that this command applies to.

*service* — Specify the service instance that this command applies to.

**Values** 1 — 2147483647

**wait-time** *wait-time* — Specify the number of seconds to wait for the response.

**Values** 1 — 60

**Default** 10

**Mtrace Output Fields** — The following table describes the output fields:

| Label           | Description                                                                                                           |
|-----------------|-----------------------------------------------------------------------------------------------------------------------|
| hop             | Number of hops from the source to the listed router.                                                                  |
| router name     | Name of the router for this hop. If a DNS name query is not successful a “?” displays.                                |
| address         | Address of the router for this hop.                                                                                   |
| protocol        | Protocol used.                                                                                                        |
| ttl             | Forward TTL threshold. TTL that a packet is required to have before it will be forwarded over the outgoing interface. |
| forwarding code | Forwarding information/error code for this hop.                                                                       |

```
A:Dut-F# mtrace source 10.10.16.9 group 224.5.6.7
```

```
Mtrace from 10.10.16.9 via group 224.5.6.7
Querying full reverse path...
```

```
0 ? (10.10.10.6)
-1 ? (10.10.10.5) PIM thresh^ 1 No Error
-2 ? (10.10.6.4) PIM thresh^ 1 No Error
-3 ? (10.10.4.2) PIM thresh^ 1 Reached RP/Core
-4 ? (10.10.1.1) PIM thresh^ 1 No Error
-5 ? (10.10.2.3) PIM thresh^ 1 No Error
-6 ? (10.10.16.9)
```

```
Round trip time 29 ms; total ttl of 5 required.
```



---

## Show Commands

---

### IGMP Commands

#### group

**Syntax** `group [grp-ip-address]`  
**group summary**

**Context** `show>router>igmp`

**Description** This command displays the multicast group and (S,G) addresses. If no *grp-ip-address* parameters are specified then all IGMP group, (\*,G) and (S,G) addresses are displayed.

**Parameters** *grp-ip-address* — Displays specific multicast group addresses.

**Output** **IGMP Group Output** — The following table describes the output fields for IGMP group information.

| Label       | Description                                                                                                 |
|-------------|-------------------------------------------------------------------------------------------------------------|
| IGMP Groups | Displays the IP multicast sources corresponding to the IP multicast groups which are statically configured. |
| Fwd List    | Displays the list of interfaces in the forward list.                                                        |
| Blk List    | Blk List                                                                                                    |

#### Sample Output

```
*B:Dut-C# show router igmp group
=====
IGMP Interface Groups
=====
IGMP Host Groups
=====
(*,225.0.0.1)
 Fwd List : 112.112.1.2 Up Time : 0d 00:00:21
(11.11.0.1,225.0.0.1)
 Fwd List : 112.112.1.1 Up Time : 0d 00:00:30
 Blk List : 112.112.1.2 Up Time : 0d 00:00:21
(11.11.0.2,225.0.0.1)
 Fwd List : 112.112.1.1 Up Time : 0d 00:00:30
(*,225.0.0.2)
 Fwd List : 112.112.1.2 Up Time : 0d 00:00:21
(11.11.0.1,225.0.0.2)
 Blk List : 112.112.1.2 Up Time : 0d 00:00:21

(*,G)/(S,G) Entries : 5
=====
```

## Show Commands

```
*B:Dut-C#
*B:Dut-C# show router igmp group summary
=====
IGMP Interface Groups
=====
IGMP Host Groups Summary Nbr Fwd Hosts Nbr Blk Hosts
=====
(*,225.0.0.1) 1 0
(11.11.0.1,225.0.0.1) 1 1
(11.11.0.2,225.0.0.1) 1 0
(*,225.0.0.2) 1 0
(11.11.0.1,225.0.0.2) 0 1

(*,G)/(S,G) Entries : 5
=====
*B:Dut-C#
A:NYC# show router igmp group 224.24.24.24
=====
IGMP Groups
=====
(*,224.24.24.24) Up Time : 0d 05:23:23
 Fwd List : nyc-vlc

(*,G)/(S,G) Entries : 1
=====
A:NYC#
```

## hosts

**Syntax** **hosts** [group *grp-address*] [detail] [fwd-service *service-id*] [grp-interface *ip-int-name*]  
**hosts** [host *ip-address*] [group *grp-address*] [detail]  
**hosts summary**

**Context** show>router>igmp

**Description** This command shows IGMP hosts information.

### Sample Output

```
*B:Dut-C# show router igmp hosts
=====
IGMP Hosts
=====
Host Oper Oper Fwd GrpItf Num Subscriber
 State Version Svc Groups

112.112.1.1 Up 3 1 gi_1_1 1 sub_1
112.112.1.2 Up 3 1 gi_1_1 2 sub_1
112.112.1.3 Up 3 1 gi_1_2 0 sub_2

Hosts : 3
=====
```

\*B:Dut-C#

\*B:Dut-C# show router igmp hosts detail

=====

IGMP Host 112.112.1.1

=====

```

Oper Status : Up MacAddress : 00:00:00:00:00:01
Oper version : 3 Subscriber : sub_1
Num Groups : 1 GrpItf : gi_1_1
Max Grps Till Now: 2 IGMP-Policy : poll
PPPoE SessionId : 1 Next query time: 0d 00:02:03
FwdSvcId : 1

```

-----

IGMP Group

-----

```

Group Address : 225.0.0.1 Up Time : 0d 00:00:24
Expires : Not running Mode : Include
V1 Host Timer : Not running Type : Dynamic
V2 Host Timer : Not running Compat Mode : IGMP Version 3
Redir.vRtrId : N/A Redir.Intf : N/A

```

```

Source Address Expires Type Fwd/Blk

11.11.0.1 0d 00:03:56 Dynamic Fwd
11.11.0.2 0d 00:03:56 Dynamic Fwd

```

=====

IGMP Host 112.112.1.2

=====

```

Oper Status : Up MacAddress : 00:00:00:00:00:01
Oper version : 3 Subscriber : sub_1
Num Groups : 2 GrpItf : gi_1_1
Max Grps Till Now: 2 IGMP-Policy : poll
PPPoE SessionId : 2 Next query time: 0d 00:02:03
FwdSvcId : 1

```

-----

IGMP Group

-----

```

Group Address : 225.0.0.1 Up Time : 0d 00:00:16
Expires : 0d 00:04:05 Mode : Exclude
V1 Host Timer : Not running Type : Dynamic
V2 Host Timer : Not running Compat Mode : IGMP Version 3
Redir.vRtrId : N/A Redir.Intf : N/A

```

```

Source Address Expires Type Fwd/Blk

11.11.0.1 0d 00:00:00 Dynamic Blk

```

-----

IGMP Group

-----

```

Group Address : 225.0.0.2 Up Time : 0d 00:00:16
Expires : 0d 00:04:04 Mode : Exclude
V1 Host Timer : Not running Type : Dynamic
V2 Host Timer : Not running Compat Mode : IGMP Version 3
Redir.vRtrId : N/A Redir.Intf : N/A

```

```

Source Address Expires Type Fwd/Blk

11.11.0.1 0d 00:00:00 Dynamic Blk

```

## Show Commands

```
=====
IGMP Host 112.112.1.3
=====
Oper Status : Up MacAddress : 00:00:00:00:00:02
Oper version : 3 Subscriber : sub_2
Num Groups : 0 GrpItf : gi_1_2
Max Grps Till Now: 1 IGMP-Policy : poll
PPPoE SessionId : 1 Next query time: 0d 00:00:48
FwdSvcId : 1

Hosts : 3
=====
*B:Dut-C#

*B:Dut-C# show router igmp statistics host 112.112.1.1
=====
IGMP Host Statistics 112.112.1.1
=====
Message Type Received Transmitted

Queries 0 580
Report V1 0 0
Report V2 0 0
Report V3 5 0
Leaves 0 0

General Host Statistics

Bad Length : 0
Bad Checksum : 0
Unknown Type : 0
Bad Receive If : 0
Rx Non Local : 0
Rx Wrong Version : 0
Policy Drops : 0
No Router Alert : 0
Rx Bad Encodings : 0
Local Scope Pkts : 0
Resvd Scope Pkts : 0
MCAC Policy Drops : 0

Source Group Statistics

(S,G) : 0
(*,G) : 0
=====
*B:Dut-C# show subscriber-mgmt igmp-policy
```

## ssm-translate

**Syntax** **ssm-translate**  
**ssm-translate interface** *interface-name*

**Context** show>router>igmp

**Description** This command displays IGMP SSM translate configuration information.

**Output** **IGMP Interface Output** — The following table provides IGMP field descriptions.

| Label                 | Description                                                                             |
|-----------------------|-----------------------------------------------------------------------------------------|
| Group Range           | Displays the address ranges of the multicast groups for which this router can be an RP. |
| Source                | Displays the unicast address that sends data on an interface.                           |
| SSM Translate Entries | Displays the total number of SSM translate entries.                                     |

### Sample Output

```

=====
IGMP SSM Translate Entries
=====
Group Range Source Interface

<234.1.1.1 - 234.1.1.2> 100.1.1.1 -
<232.1.1.1 - 232.1.1.5> 100.1.1.2 ies-abc
=====

```

## interface

**Syntax** **interface** [*ip-int-name* | *ip-address*] [**group**] [*grp-address*] [**detail**]

**Context** show>router>igmp

**Description** This command displays IGMP interface information.

**Parameters** *ip-int-name* — Only displays the information associated with the specified IP interface name.  
*ip-address* — Only displays the information associated with the specified IP address.  
**group** *grp-address* — Only displays IP multicast group address for which this entry contains information.  
**detail** — Displays detailed IP interface information along with the source group information learned on that interface.

**Output IGMP Interface Output** — The following table provides IGMP field descriptions.

| Label                                 | Description                                                                                                                                                                                                                                                                                                                                                                                                                                                                    |
|---------------------------------------|--------------------------------------------------------------------------------------------------------------------------------------------------------------------------------------------------------------------------------------------------------------------------------------------------------------------------------------------------------------------------------------------------------------------------------------------------------------------------------|
| Interface                             | Specifies the interfaces that participate in the IGMP protocol.                                                                                                                                                                                                                                                                                                                                                                                                                |
| Adm<br>Admin Status                   | Displays the administrative state for the IGMP protocol on this interface.                                                                                                                                                                                                                                                                                                                                                                                                     |
| Oper<br>Oper Status                   | Displays the current operational state of IGMP protocol on the interface.                                                                                                                                                                                                                                                                                                                                                                                                      |
| Querier                               | Displays the address of the IGMP querier on the IP subnet to which the interface is attached.                                                                                                                                                                                                                                                                                                                                                                                  |
| Querier Up Time                       | Displays the time since the querier was last elected as querier.                                                                                                                                                                                                                                                                                                                                                                                                               |
| Querier Expiry<br>Timer               | Displays the time remaining before the querier ages out. If the querier is the local interface address, the value will be zero.                                                                                                                                                                                                                                                                                                                                                |
| Cfg/Opr Version<br>Admin/Oper version | Cfg — The configured version of IGMP running on this interface. For IGMP to function correctly, all routers on a LAN must be configured to run the same version of IGMP on that LAN.<br>Opr — The operational version of IGMP running on this interface. If the cfg value is 3 but all of the routers in the local subnet of this interface use IGMP version v1 or v2, the operational version will be v1 or v2.                                                               |
| Num Groups                            | The number of multicast groups which have been learned by the router on the interface.                                                                                                                                                                                                                                                                                                                                                                                         |
| Policy                                | Specifies the policy that is to be applied on the interface.                                                                                                                                                                                                                                                                                                                                                                                                                   |
| Group Address                         | Specifies the IP multicast group address for which this entry contains information.                                                                                                                                                                                                                                                                                                                                                                                            |
| Up Time                               | Specifies the time since this source group entry got created.                                                                                                                                                                                                                                                                                                                                                                                                                  |
| Last Reporter                         | Specifies the IP address of the source of the last membership report received for this IP Multicast group address on this interface. If no membership report has been received, this object has the value 0.0.0.0.                                                                                                                                                                                                                                                             |
| Mode                                  | The mode is based on the type of membership report(s) received on the interface for the group. In the 'include' mode, reception of packets sent to the specified multicast address is requested only from those IP source addresses listed in the source-list parameter of the IGMP membership report. In 'exclude' mode, reception of packets sent to the given multicast address is requested from all IP source addresses except those listed in the source-list parameter. |



| Label         | Description (Continued)                                                                                                                                                                                                                                                                                                                                                                                                                                                                                                                                                                               |
|---------------|-------------------------------------------------------------------------------------------------------------------------------------------------------------------------------------------------------------------------------------------------------------------------------------------------------------------------------------------------------------------------------------------------------------------------------------------------------------------------------------------------------------------------------------------------------------------------------------------------------|
| V1 Host Timer | The time remaining until the local router will assume that there are no longer any IGMP version 1 members on the IP subnet attached to this interface. Upon hearing any IGMPv1 Membership Report, this value is reset to the group membership timer. While this time remaining is non-zero, the local router ignores any IGMPv2 Leave messages for this group that it receives on this interface.                                                                                                                                                                                                     |
| V2 Host Timer | The time remaining until the local router will assume that there are no longer any IGMP version 2 members on the IP subnet attached to this interface. Upon hearing any IGMPv2 Membership Report, this value is reset to the group membership timer. While this time remaining is non-zero, the local router ignores any IGMPv3 Leave messages for this group that it receives on this interface.                                                                                                                                                                                                     |
| Type          | Indicates how this group entry was learned. If this group entry was learned by IGMP, it will be set to "dynamic". For statically configured groups, the value will be set to 'static'.                                                                                                                                                                                                                                                                                                                                                                                                                |
| Compat Mode   | Used in order for routers to be compatible with older version routers. IGMPv3 hosts MUST operate in version 1 and version 2 compatibility modes. IGMPv3 hosts MUST keep state per local interface regarding the compatibility mode of each attached network. A host's compatibility mode is determined from the Host Compatibility Mode variable which can be in one of three states: IGMPv1, IGMPv2 or IGMPv3. This variable is kept per interface and is dependent on the version of General Queries heard on that interface as well as the Older Version Querier Present timers for the interface. |

### Sample Output

```
*A:ALA-BA# show router 100 interface
=====
Interface Table (Service: 100)
=====
Interface-Name Adm Opr (v4/v6) Mode Port/SapId
IP-Address

IGMP_to_CE Up Up VPRN 1/1/7
 11.1.1.1/24 n/a
system Up Up VPRN loopback
 10.20.1.2/32 n/a

Interfaces : 2
=====
*A:ALA-BA#

*A:ALA-BA# show router 100 interface IGMP_to_CE
=====
Interface Table (Service: 100)
=====
Interface-Name Adm Opr (v4/v6) Mode Port/SapId
```

## Show Commands

```

 IP-Address PfxState

IGMP_to_CE Up Up VPRN 1/1/7
11.1.1.1/24 n/a

Interfaces : 1
=====
*A:ALA-BA#

*A:ALA-BA# show router 100 igmp interface
=====
IGMP Interfaces
=====
Interface Adm Oper Querier Cfg/Opr Num Policy
 Version Groups

IGMP_to_CE Up Up 11.1.1.1 1/1 3 igmppol

Interfaces : 1
=====
*A:ALA-BA#

*A:ALA-BA# show router 100 igmp interface IGMP_to_CE
=====
IGMP Interface IGMP_to_CE
=====
Interface Adm Oper Querier Cfg/Opr Num Policy
 Version Groups

IGMP_to_CE Up Up 11.1.1.1 1/1 3 igmppol

Interfaces : 1
=====
*A:ALA-BA#

*A:ALA-BA# show router 100 igmp interface 11.1.1.1
=====
IGMP Interface 11.1.1.1
=====
Interface Adm Oper Querier Cfg/Opr Num Policy
 Version Groups

IGMP_to_CE Up Up 11.1.1.1 1/1 3 igmppol

Interfaces : 1
=====
*A:ALA-BA#

```

```

*A:ALA-BA# show router 100 igmp interface IGMP_to_CE group 227.1.1.1
=====
IGMP Interface IGMP_to_CE
=====
Interface Adm Oper Querier Cfg/Opr Num Policy
 Up Up 11.1.1.1 1/1 3 igmppol

IGMP Group

Group Address : 227.1.1.1 Up Time : 0d 00:03:52
Interface : IGMP_to_CE Expires : never
Last Reporter : 0.0.0.0 Mode : exclude
V1 Host Timer : Not running Type : static
V2 Host Timer : Not running Compat Mode : IGMP Version 3

Interfaces : 1
=====
*A:ALA-BA#

*A:ALA-BA# show router 100 igmp interface IGMP_to_CE group 227.1.1.1 detail
=====
IGMP Interface IGMP_to_CE
=====
Interface : IGMP_to_CE
Admin Status : Up
Querier : 11.1.1.1
Querier Expiry Time: N/A
Admin/Oper version : 1/1
Policy : igmppol
Max Groups Allowed : 16000
MCAC Policy Name :
MCAC Max Unconst BW: no limit
MCAC In use Mand BW: 0
MCAC In use Opnl BW: 0
Oper Status : Up
Querier Up Time : 0d 00:04:01
Time for next query: 0d 00:13:42
Num Groups : 3
Subnet Check : Disabled
Max Groups Till Now: 3
MCAC Const Adm St : Enable
MCAC Max Mand BW : no limit
MCAC Avail Mand BW: unlimited
MCAC Avail Opnl BW: unlimited

IGMP Group

Group Address : 227.1.1.1 Up Time : 0d 00:04:02
Interface : IGMP_to_CE Expires : never
Last Reporter : 0.0.0.0 Mode : exclude
V1 Host Timer : Not running Type : static
V2 Host Timer : Not running Compat Mode : IGMP Version 3

Interfaces : 1
=====
*A:ALA-BA#

```

## static

**Syntax** `static [ip-int-name | ip-addr]`

**Context** `show>router>igmp`

**Description** This command displays static IGMP, (\*,G) and (S,G) information.

**Parameters** *ip-int-name* — Only displays the information associated with the specified IP interface name.

*ip-addr* — Only displays the information associated with the specified IP address.

**Output** **Static IGMP Output** — The following table provides static IGMP field descriptions.

| Label     | Description                                                                                                                           |
|-----------|---------------------------------------------------------------------------------------------------------------------------------------|
| Source    | Displays entries which represents a source address from which receivers are interested/not interested in receiving multicast traffic. |
| Group     | Displays the IP multicast group address for which this entry contains information.                                                    |
| Interface | Displays the interface name.                                                                                                          |

### Sample Output

```
*A:ALA-BA# show router 100 igmp static
=====
IGMP Static Group Source
=====
Source Group Interface

11.11.11.11 226.136.22.3 IGMP_to_CE
* 227.1.1.1 IGMP_to_CE
22.22.22.22 239.255.255.255 IGMP_to_CE

Static (*,G)/(S,G) Entries : 3
=====
*A:ALA-BA#
```

## statistics

**Syntax** `statistics [ip-int-name | ip-address]`  
**statistics host [ip-address]**

**Context** `show>router>igmp`

**Description** This command displays IGMP statistics information.

**Parameters** *ip-int-name* — Only displays the information associated with the specified IP interface name.

*ip-address* — Only displays the information associated with the specified IP address.

**Output IGMP Statistics Output** — The following table provides statistical IGMP field descriptions.

| Label                        | Description                                                                                                                                                                                                                                                                                                  |
|------------------------------|--------------------------------------------------------------------------------------------------------------------------------------------------------------------------------------------------------------------------------------------------------------------------------------------------------------|
| IGMP Interface Statistics    | The section listing the IGMP statistics for a particular interface.                                                                                                                                                                                                                                          |
| Message Type                 | <p><b>Queries</b> — The number of IGMP general queries transmitted or received on this interface.</p> <p><b>Report</b> — The total number of IGMP V1, V2, or V3 reports transmitted or received on this interface.</p> <p><b>Leaves</b> — The total number of IGMP leaves transmitted on this interface.</p> |
| Received                     | Displays the total number of IGMP packets received on this interface.                                                                                                                                                                                                                                        |
| Transmitted                  | Column that displays the total number of IGMP packets transmitted from this interface.                                                                                                                                                                                                                       |
| General Interface Statistics | The section listing the general IGMP statistics.                                                                                                                                                                                                                                                             |
| Bad Length                   | Displays the total number of IGMP packets with bad length received on this interface.                                                                                                                                                                                                                        |
| Bad Checksum                 | Displays the total number of IGMP packets with bad checksum received on this interface.                                                                                                                                                                                                                      |
| Unknown Type                 | Displays the total number of IGMP packets with unknown type received on this interface.                                                                                                                                                                                                                      |
| Bad Receive If               | Displays the total number of IGMP packets incorrectly received on this interface.                                                                                                                                                                                                                            |
| Rx Non Local                 | Displays the total number of IGMP packets received from a non-local sender.                                                                                                                                                                                                                                  |
| Rx Wrong Version             | Displays the total number of IGMP packets with wrong versions received on this interface.                                                                                                                                                                                                                    |
| Policy Drops                 | Displays the total number of times IGMP protocol instance matched the host IP address or group/source addresses specified in the import policy.                                                                                                                                                              |
| No Router Alert              | Displays the total number of IGMPv3 packets received on this interface which did not have the router alert flag set.                                                                                                                                                                                         |

## Show Commands

### Sample Output

```
*A:ALA-BA# show router 100 igmp statistics
=====
IGMP Interface Statistics
=====
Message Type Received Transmitted

Queries 0 5
Report V1 0 0
Report V2 0 0
Report V3 0 0
Leaves 0 0

General Interface Statistics

Bad Length : 0
Bad Checksum : 0
Unknown Type : 0
Bad Receive If : 0
Rx Non Local : 0
Rx Wrong Version : 0
Policy Drops : 0
No Router Alert : 0
Rx Bad Encodings : 0
Rx Pkt Drops : 0

Source Group Statistics

(S,G) : 2
(*,G) : 1
=====
*A:ALA-BA#
```

```
*B:Dut-C# show router igmp statistics host
=====
IGMP Host Statistics
=====
Message Type Received Transmitted

Queries 0 1739
Report V1 0 0
Report V2 0 0
Report V3 10 0
Leaves 0 0

General Host Statistics

Bad Length : 0
Bad Checksum : 0
Unknown Type : 0
Bad Receive If : 0
Rx Non Local : 0
Rx Wrong Version : 0
Policy Drops : 0
No Router Alert : 0
Rx Bad Encodings : 0
Local Scope Pkts : 0
```

```

Resvd Scope Pkts : 0
MCAC Policy Drops : 0
=====
*B:Dut-C#

```

## status

**Syntax** status

**Context** show>router>igmp

**Description** This command displays IGMP status information.  
If IGMP is not enabled, the following message appears:

```

A:NYC# show router igmp status
MINOR: CLI IGMP is not configured.
A:NYC#

```

**Output** **IGMP Status Output** — The following table provides IGMP status field descriptions.

| Label                      | Description                                                                                                                                                                    |
|----------------------------|--------------------------------------------------------------------------------------------------------------------------------------------------------------------------------|
| Admin State                | Displays the administrative status of IGMP.                                                                                                                                    |
| Oper State                 | Displays the current operating state of this IGMP protocol instance on this router.                                                                                            |
| Query Interval             | The frequency at which IGMP query packets are transmitted.                                                                                                                     |
| Last Member Query Interval | The maximum response time inserted into group-specific queries sent in response to leave group messages, and is also the amount of time between group-specific query messages. |
| Query Response Interval    | The maximum query response time advertised in IGMPv2 queries.                                                                                                                  |
| Robust Count               | Displays the number of times the router will retry a query.                                                                                                                    |

## Sample Output

```

*A:ALA-BA# show router 100 igmp status
=====
IGMP Status
=====
Admin State : Up
Oper State : Up
Query Interval : 1024
Last Member Query Interval : 1024
Query Response Interval : 1023
Robust Count : 10
=====
*A:ALA-BA#

```

---

## Show Router PIM Commands

### anycast

**Syntax** `anycast [detail]`

**Context** `show>router>pim`

**Description** This command displays PIM anycast rp-set information.

**Parameters** `detail` — Displays detailed information.

**Output** **PIM anycast Output** — The following table provides PIM anycast field descriptions

| Label           | Description                                     |
|-----------------|-------------------------------------------------|
| Anycast Address | Displays the candidate anycast address.         |
| Anycast RP Peer | Displays the candidate anycast RP peer address. |

### Sample Output

```
A:dut-d# show router pim anycast
=====
PIM Anycast RP Entries
=====
Anycast RP Anycast RP Peer

100.100.100.1 102.1.1.1
 103.1.1.1
 104.1.1.1

PIM Anycast RP Entries : 3
=====
```

### crp

**Syntax** `crp [ip-address]`

**Context** `show>router>pim`

**Description** Display PIM candidate RP (CRP) information received at the elected Bootstrap router (BSR).

**Parameters** `ip-address` — The candidate RP IP address.



**Output PIM CRP Output** — The following table provides PIM CRP field descriptions.

| Label         | Description                                                                                                                                                                              |
|---------------|------------------------------------------------------------------------------------------------------------------------------------------------------------------------------------------|
| RP Address    | Displays the Candidate RP address.                                                                                                                                                       |
| Group Address | Displays the range of multicast group addresses for which the CRP is the Candidate RP.                                                                                                   |
| Priority      | Displays the Candidate RP's priority for becoming a rendezvous point (RP). This value is used to elect RP for a group range. A value of 0 is considered as the highest priority.         |
| Holdtime      | Displays the hold time of the candidate RP. It is used by the Bootstrap router to time out the RP entries if it does not listen to another CRP advertisement within the holdtime period. |
| Expiry        | The minimum time remaining before the CRP will be declared down. If the local router is not the BSR, this value is 0.                                                                    |
| Candidate RPs | Displays the number of CRP entries.                                                                                                                                                      |

### Sample Output

```
A:WAS# show router pim crp
=====
PIM Candidate RPs
=====
RP Address Group Address Priority Holdtime Expiry Time

2.22.187.236 224.0.0.0/4 192 150 0d 00:02:19
2.22.187.239 224.0.0.0/4 192 150 0d 00:02:19
2.22.187.240 224.0.0.0/4 192 150 0d 00:02:09

Candidate RPs : 3
=====
A:WAS#

A:WAS# show router pim crp 2.22.187.236
=====
PIM Candidate RPs
=====
RP Address Group Address Priority Holdtime Expiry Time

2.22.187.236 224.0.0.0/4 192 150 0d 00:01:43

Candidate RPs : 1
=====
A:WAS#
```

## Show Router PIM Commands

### s-pmsi

**Syntax** **s-pmsi** [*mdSrcAddr* [*mdGrpAddr*]] [**detail**]

**Context** show>router>pim

**Description** Displays the list of selective provider multicast service interfaces that are currently active.

**Parameters** *mdSrcAddr* — Specifies the source address of the multicast sender.

*mdGrpAddr* — Specifies the group address of the multicast sender.

**detail** — Displays detailed output.

**Output** **PIM data MDT Output** — The following table provides PIM data MDT descriptions.

| Label          | Description                                                                                                                                                                                                       |
|----------------|-------------------------------------------------------------------------------------------------------------------------------------------------------------------------------------------------------------------|
| MD Grp Address | Displays the IP multicast group address for which this entry contains information.                                                                                                                                |
| MD Src Address | Displays the source address of the multicast sender.<br>It will be 0 if the type is configured as <b>starg</b> . It will be the address of the Rendezvous Point (RP) if the type is configured as <b>starRP</b> . |
| MT Index       | Displays the index number.                                                                                                                                                                                        |
| Num VP SGs     | Displays the VPN number.                                                                                                                                                                                          |

### Sample Output

```
*B:node-6# show router 100 pim s-pmsi
=====
PIM Selective provider tunnels
=====
MD Src Address MD Grp Address MT Index Num VPN SGs

200.200.200.7 230.0.89.72 24603 1
200.200.200.7 230.0.89.73 24604 1
200.200.200.7 230.0.89.74 24605 1
200.200.200.7 230.0.89.75 24606 1
200.200.200.7 230.0.89.76 24607 1
200.200.200.7 230.0.89.77 24608 1
200.200.200.7 230.0.89.78 24609 1
200.200.200.7 230.0.89.79 24610 1
200.200.200.7 230.0.89.80 24611 1
200.200.200.7 230.0.89.81 24612 1
200.200.200.7 230.0.89.82 24613 1
200.200.200.7 230.0.89.83 24614 1
200.200.200.7 230.0.89.84 24615 1
200.200.200.7 230.0.89.85 24616 1
200.200.200.7 230.0.89.86 24617 1
200.200.200.7 230.0.89.87 24618 1
...
=====
*B:node-6#
```

```

*B:node-6# show router 100 pim s-pmsi detail
=====
PIM Selective provider tunnels
=====
Md Source Address : 200.200.200.7 Md Group Address : 230.0.89.72
Number of VPN SGs : 1 Uptime : 0d 00:00:18
MT IfIndex : 24603 Egress Fwding Rate : 163.2 kbps

VPN Group Address : 228.1.0.0 VPN Source Address : 11.2.102.1
State : RX Joined
Expiry Timer : 0d 00:02:41
=====
PIM Selective provider tunnels
=====
Md Source Address : 200.200.200.7 Md Group Address : 230.0.89.73
Number of VPN SGs : 1 Uptime : 0d 00:00:18
MT IfIndex : 24604 Egress Fwding Rate : 163.2 kbps

VPN Group Address : 228.1.0.1 VPN Source Address : 11.2.102.1
State : RX Joined
Expiry Timer : 0d 00:02:41
=====
PIM Selective provider tunnels
=====
Md Source Address : 200.200.200.7 Md Group Address : 230.0.89.74
Number of VPN SGs : 1 Uptime : 0d 00:00:20
MT IfIndex : 24605 Egress Fwding Rate : 165.7 kbps

VPN Group Address : 228.1.0.2 VPN Source Address : 11.2.102.1
State : RX Joined
Expiry Timer : 0d 00:02:39
=====
PIM Selective provider tunnels
=====
Md Source Address : 200.200.200.7 Md Group Address : 230.0.89.75
Number of VPN SGs : 1 Uptime : 0d 00:00:20
MT IfIndex : 24606 Egress Fwding Rate : 165.7 kbps

VPN Group Address : 228.1.0.3 VPN Source Address : 11.2.102.1
State : RX Joined
Expiry Timer : 0d 00:02:39
=====
*B:node-6#

```

## group

**Syntax** `group grp-ip-address [source ip-address [type {starstarrp | starg | sg}] [detail] [family]`

**Context** show>router>pim

**Description** This command displays PIM source group database information.

**Parameters** *grp-ip-address* — Specifies the IP multicast group address for which this entry contains information.

*source ip-address* — Specifies the source address for which this entry contains information.

**type *starstarrp*** — Specifies that only (\*, \*, rp) entries be displayed.

## Show Router PIM Commands

**type starg** — Specifies that only (\*,G) entries be displayed.

**type sg** — specifies that only (S,G) entries be displayed.

**detail** — Displays detailed group information.

*family* — Displays either IPv4 or IPv6 information.

**Output PIM Group Output** — The following table provides PIM Group field descriptions.

| Label               | Description                                                                                                                                                                                                                            |
|---------------------|----------------------------------------------------------------------------------------------------------------------------------------------------------------------------------------------------------------------------------------|
| Group Address       | Displays the IP multicast group address for which this entry contains information.                                                                                                                                                     |
| Source Address      | Displays the source address of the multicast sender. It will be 0 if the type is configured as starg. It will be the address of the Rendezvous Point (RP) if the type is configured as starRP.                                         |
| RP Address          | Displays the RP address.                                                                                                                                                                                                               |
| Type                | Specifies the type of entry, (*,*, rp)/(*,G) or (S,G).                                                                                                                                                                                 |
| Spt Bit             | Specifies whether to forward on (*,*, rp)/(*,G) or on (S,G) state. It is updated when the (S,G) data comes on the RPF interface towards the source.                                                                                    |
| Incoming Intf       | Displays the interface on which the traffic comes in. It can be the RPF interface to the RP (if starg) or the source (if sg).                                                                                                          |
| Num Oifs            | Displays the number of interfaces in the inherited outgoing interface list. An inherited list inherits the state from other types.                                                                                                     |
| Flags               | Displays the different lists that this interface belongs to.                                                                                                                                                                           |
| Keepalive Timer Exp | The keepalive timer is applicable only for (S,G) entries. The (S,G) keepalive timer is updated by data being forwarded using this (S,G) Forwarding state. It is used to keep (S,G) state alive in the absence of explicit (S,G) joins. |
| MRIB Next Hop       | Displays the next hop address towards the RP.                                                                                                                                                                                          |
| MRIB Src Flags      | Displays the MRIB information about the source. If the entry is of type starg or starstarrp, it will contain information about the RP for the group.                                                                                   |
| Up Time             | Displays the time since this source group entry was created.                                                                                                                                                                           |
| Resolved By         | Displays the route table used for RPF check.                                                                                                                                                                                           |
| Up JP State         | Displays the upstream join prune state for this entry on the interface. PIM join prune messages are sent by the downstream routers towards the RPF neighbor.                                                                           |

| Label                    | Description (Continued)                                                                                                                                                                                                                                                                                                                                                                                                                                                                                                                                                                                                                                                                |
|--------------------------|----------------------------------------------------------------------------------------------------------------------------------------------------------------------------------------------------------------------------------------------------------------------------------------------------------------------------------------------------------------------------------------------------------------------------------------------------------------------------------------------------------------------------------------------------------------------------------------------------------------------------------------------------------------------------------------|
| Up JP Expiry             | Displays the minimum amount of time remaining before this entry will be aged out.                                                                                                                                                                                                                                                                                                                                                                                                                                                                                                                                                                                                      |
| Up JP Rpt                | Displays the join prune Rpt state for this entry on the interface. PIM join/prune messages are sent by the downstream routers towards the RPF neighbor. (S,G, rpt) state is a result of receiving (S,G, rpt) JP message from the downstream router on the RP tree.                                                                                                                                                                                                                                                                                                                                                                                                                     |
| Up JP Rpt Override       | Displays the value used to delay triggered Join (S,G, rpt) messages to prevent implosions of triggered messages.<br>If this has a non-zero value, it means that the router was in 'notPruned' state and it saw a prune (S,G, rpt) message being sent to RPF (S,G, rpt). If the router sees a join (S,G, rpt) override message being sent by some other router on the LAN while the timer is still non-zero, it simply cancels the override timer. If it does not see a join (S,G, rpt) message, then on expiry of the override timer, it sends it's own join (S,G, rpt) message to RPF (S,G, rpt). A similar scenario exists when RPF (S,G, rpt) changes to become equal to RPF (*,G). |
| Register State           | Specifies the register state. The register state is kept at the source DR. When the host starts sending multicast packets and if there are no entries programmed for that group, the source DR sends a register packet to the RP (g). Register state transition happen based on the register stop timer and the response received from the RP.                                                                                                                                                                                                                                                                                                                                         |
| Register Stop Exp        | Displays the time remaining before the register state might transition to a different state.                                                                                                                                                                                                                                                                                                                                                                                                                                                                                                                                                                                           |
| Register from Anycast RP | Displays if the register packet for that group has been received from one of the RP from the anycast-RP set.                                                                                                                                                                                                                                                                                                                                                                                                                                                                                                                                                                           |
| RPF Neighbor             | Displays the address of the RPF neighbor.                                                                                                                                                                                                                                                                                                                                                                                                                                                                                                                                                                                                                                              |
| Outgoing Intf List       | Displays a list of interfaces on which data is forwarded.                                                                                                                                                                                                                                                                                                                                                                                                                                                                                                                                                                                                                              |
| Curr Fwding Rate         | Displays the current forwarding rate of the multicast data for this group and source.                                                                                                                                                                                                                                                                                                                                                                                                                                                                                                                                                                                                  |
| Forwarded Packets        | Displays the number of multicast packets that were forwarded to the interfaces in the outgoing interface list.                                                                                                                                                                                                                                                                                                                                                                                                                                                                                                                                                                         |
| Discarded Packets        | Displays the number of multicast packets that matched this source group entry but were discarded.<br>For (S,G) entries, if the traffic is getting forwarded on the SPT, the packets arriving from the RPT will be discarded.                                                                                                                                                                                                                                                                                                                                                                                                                                                           |
| Forwarded Octets         | Displays the number of octets forwarded.                                                                                                                                                                                                                                                                                                                                                                                                                                                                                                                                                                                                                                               |
| RPF Mismatches           | Displays the number of multicast packets that matched this source group entry but they did not arrive on the interface.                                                                                                                                                                                                                                                                                                                                                                                                                                                                                                                                                                |

## Show Router PIM Commands

| Label         | Description (Continued)                                                                                                                 |
|---------------|-----------------------------------------------------------------------------------------------------------------------------------------|
| Spt threshold | Displays the value of the SPT threshold configured for that group. 0 Kbps means that the switch to the SP tree will happen immediately. |

### Sample Output

```
A:NYC>show>router>pim# group
=====
PIM Groups
=====
Group Address Source Address RP Address Type Spt Incoming Num
 Bit Intf <*,G> nyc-sjc Oifs

224.24.24.24 * 2.22.187.240 <*,G> nyc-sjc 1
239.255.255.250 * 2.22.187.240 <*,G> nyc-sjc 1

Groups : 2
=====
A:NYC>show>router>pim#

A:NYC>show>router>pim# group 239.255.255.250
=====
PIM Groups
=====
Group Address Source Address RP Address Type Spt Incoming Num
 Bit Intf <*,G> nyc-sjc Oifs

239.255.255.250 * 2.22.187.240 <*,G> nyc-sjc 1

Groups : 1
=====
A:NYC>show>router>pim#

A:NYC>show>router>pim# group 239.255.255.250 detail
=====
PIM Source Group
=====
Group Address : 239.255.255.250 Source Address : 16.1.1.2
RP Address : 100.100.100.1 Type : (S,G)
Flags : spt, rpt-prn-des Keepalive Timer Exp: 0d 00:03:07
MRIB Next Hop : 16.1.1.2 MRIB Src Flags : direct
Up Time : 0d 00:00:50 Resolved By : rtable-u

Up JP State : Joined Up JP Expiry : 0d 00:00:00
Up JP Rpt : Pruned Up JP Rpt Override : 0d 00:00:00

Register State : Pruned Register Stop Exp : 0d 00:00:47
Reg From Anycast RP: No

RPF Neighbor : 16.1.1.2
Incoming Intf : SOURCE-3
Outgoing Intf List : To-Dut-A

Curr Fwding Rate : 482.9 kbps
```

```

Forwarded Packets : 1262 Discarded Packets : 0
Forwarded Octets : 1269572 RPF Mismatches : 0
Spt threshold : 0 kbps
=====

```

A:NYC>show>router>pim#

B:Dut-C# show router pim group 225.0.0.1 type sg detail

```

=====
PIM Source Group ipv4
=====
Group Address : 225.0.0.1
Source Address : 11.11.0.1
RP Address : 10.20.1.3
Flags : rpt-prn-des Type : (S,G)
MRIB Next Hop : 11.11.0.1
MRIB Src Flags : direct Keepalive Timer : Not Running
Up Time : 0d 00:04:17 Resolved By : rtable-u

Up JP State : Joined Up JP Expiry : 0d 00:00:00
Up JP Rpt : Pruned Up JP Rpt Override : 0d 00:00:00

Register State : No Info
Reg From Anycast RP: No

Rpf Neighbor : 11.11.0.1
Incoming Intf : svc_itf
Outgoing Host List : 112.112.1.1

Curr Fwding Rate : 0.0 kbps
Forwarded Packets : 0 Discarded Packets : 0
Forwarded Octets : 0 RPF Mismatches : 0
Spt threshold : 0 kbps ECMP opt threshold : 7
Admin bandwidth : 1 kbps Preference : 0

```

```

=====
PIM Source Group ipv4
=====
Group Address : 225.0.0.1
Source Address : 11.11.0.2
RP Address : 10.20.1.3
Flags : Type : (S,G)
MRIB Next Hop : 11.11.0.2
MRIB Src Flags : direct Keepalive Timer : Not Running
Up Time : 0d 00:04:18 Resolved By : rtable-u

Up JP State : Joined Up JP Expiry : 0d 00:00:00
Up JP Rpt : Not Pruned Up JP Rpt Override : 0d 00:00:00

Register State : No Info
Reg From Anycast RP: No

Rpf Neighbor : 11.11.0.2
Incoming Intf : svc_itf
Outgoing Host List : 112.112.1.1, 112.112.1.2

Curr Fwding Rate : 0.0 kbps
Forwarded Packets : 0 Discarded Packets : 0
Forwarded Octets : 0 RPF Mismatches : 0

```

## Show Router PIM Commands

```

Spt threshold : 0 kbps ECMP opt threshold : 7
Admin bandwidth : 1 kbps Preference : 0

Groups : 2
=====
*B:Dut-C#

```

## interface

**Syntax** **interface** [*ip-int-name* | *mt-int-name* | *ip-address*] [**group** *grp-ip-address* | **source** *ip-address* [**type** {**starstarrp** | **starg** | **sg**}] [**detail**] [**family**]

**Context** show>router>pim

**Description** This command displays PIM interface information and the (S,G)/(\*,G)/(\*, \*, rp) state of the interface.

**Parameters** *ip-int-name* — Only displays the interface information associated with the specified IP interface name.

*ip-address* — Only displays the interface information associated with the specified IP address.

**group** *grp-ip-address* — Specifies the IP multicast group address for which this entry contains information.

**source** *ip-address* — Specifies the source address for which this entry contains information.

If the type is **starg**, the value of this object will be zero.

If the type is **starstarrp**, the value of this object will be address of the RP.

**type** — Specifies the type of this entry.

**Values** **starstarrp**, **starg**, **sg**

**detail** — Displays detailed interface information.

**family** — Displays IPv4 or IPv6 information for the interface.

**Output** **PIM Interface Output** — The following table provides PIM interface field descriptions.

| Label       | Description                                                                                                             |
|-------------|-------------------------------------------------------------------------------------------------------------------------|
| Admin State | Displays the administrative state for PIM protocol on this interface.                                                   |
| Oper State  | Displays the current operational state of PIM protocol on this interface.                                               |
| DR          | Displays the designated router on this PIM interface.                                                                   |
| DR Priority | Displays the priority value sent in PIM Hello messages and that is used by routers to elect the designated router (DR). |
| Hello Intvl | Indicates the frequency at which PIM Hello messages are transmitted on this interface.                                  |



## Sample Output

```
ALA-1# show router pim interface
=====
PIM Interfaces
=====
Interface Admin Oper DR DR Hello
 State State Priority Intvl

system Up Up N/A 1 30
ip-10.1.7.1 Up Up 10.1.7.7 5 30
ip-10.1.2.1 Up Up 10.1.2.2 5 30
ip-100.111.1.1 Up Up 100.111.1.1 5 30

Interfaces : 4
=====
ALA-1#
```

```
ALA-1# show router pim interface ip-10.1.2.1 detail
=====
PIM Interface ip-10.1.2.1
=====
Interface Admin Oper DR DR Hello
 State State Priority Intvl

ip-10.1.2.1 Up Up 10.1.2.2 5 30

PIM Group Source

Group Address : 228.101.0.5 Src Address : 100.111.1.2
Interface : ip-10.1.2.1 Type : <S,G>
RP Address : 200.200.200.4
Join Prune State : Join Expires : 0d 00:03:00
Prune Pend Expires : N/A

Assert State : No Info

Interfaces : 1
=====
ALA-1#
```

```
ALA-1# show router pim interface group
=====
PIM Interface ip-10.1.7.1
=====
Interface Admin Oper DR DR Hello
 State State Priority Intvl

ip-10.1.7.1 Up Up 10.1.7.7 5 30

Group Address Source Address RP Address Type JP Assert

228.101.0.0 100.111.1.2 200.200.200.4 <S,G> Join No Info
228.101.0.1 100.111.1.2 200.200.200.4 <S,G> Join No Info
228.101.0.2 100.111.1.2 200.200.200.4 <S,G> Join No Info
228.101.0.3 100.111.1.2 200.200.200.4 <S,G> Join No Info
```

## Show Router PIM Commands

```

228.101.0.4 100.111.1.2 200.200.200.4 <S,G> Join No Info
228.101.0.6 100.111.1.2 200.200.200.4 <S,G> Join No Info
228.101.0.7 100.111.1.2 200.200.200.4 <S,G> Join No Info
228.101.0.8 100.111.1.2 200.200.200.4 <S,G> Join No Info
228.101.0.9 100.111.1.2 200.200.200.4 <S,G> Join No Info
=====
PIM Interface ip-10.1.2.1
=====
Interface Admin Oper DR DR Hello
 State State Priority Intvl

ip-10.1.2.1 Up Up 10.1.2.2 5 30

Group Address Source Address RP Address Type JP Assert

228.101.0.5 100.111.1.2 200.200.200.4 <S,G> Join No Info
=====
PIM Interface ip-100.111.1.1
=====
Interface Admin Oper DR DR Hello
 State State Priority Intvl

ip-100.111.1.1 Up Up 100.111.1.1 5 30

Group Address Source Address RP Address Type JP Assert

228.102.0.0 * 200.200.200.4 <*,G> Join No Info
228.102.0.1 * 200.200.200.4 <*,G> Join No Info
228.102.0.2 * 200.200.200.4 <*,G> Join No Info
228.102.0.3 * 200.200.200.4 <*,G> Join No Info
228.102.0.4 * 200.200.200.4 <*,G> Join No Info
228.102.0.5 * 200.200.200.4 <*,G> Join No Info
228.102.0.6 * 200.200.200.4 <*,G> Join No Info
228.102.0.7 * 200.200.200.4 <*,G> Join No Info
228.102.0.8 * 200.200.200.4 <*,G> Join No Info
228.102.0.9 * 200.200.200.4 <*,G> Join No Info

Interfaces : 3
=====
ALA-1#

ALA-1# show router pim interface group 228.102.0.0 detail
=====
PIM Interface ip-100.111.1.1
=====
Interface Admin Oper DR DR Hello
 State State Priority Intvl

ip-100.111.1.1 Up Up 100.111.1.1 5 30

PIM Group Source

Group Address : 228.102.0.0 Src Address : *
Interface : ip-100.111.1.1 Type : <*,G>
RP Address : 200.200.200.4

Join Prune State : Join Expires : 0d 00:02:05
Prune Pend Expires : N/A

```

```

Assert State : No Info

Interfaces : 1
=====
ALA-1#

ALA-1# show router pim interface type starg
=====
PIM Interface ip-100.111.1.1
=====
Interface Admin Oper DR DR Hello
 State State Address Priority Intvl

ip-100.111.1.1 Up Up 100.111.1.1 5 30

Group Address Source Address RP Address Type JP Assert

228.102.0.0 * 200.200.200.4 <*,G> Join No Info
228.102.0.1 * 200.200.200.4 <*,G> Join No Info
228.102.0.2 * 200.200.200.4 <*,G> Join No Info
228.102.0.3 * 200.200.200.4 <*,G> Join No Info
228.102.0.4 * 200.200.200.4 <*,G> Join No Info
228.102.0.5 * 200.200.200.4 <*,G> Join No Info
228.102.0.6 * 200.200.200.4 <*,G> Join No Info
228.102.0.7 * 200.200.200.4 <*,G> Join No Info
228.102.0.8 * 200.200.200.4 <*,G> Join No Info
228.102.0.9 * 200.200.200.4 <*,G> Join No Info

Interfaces : 1
=====
ALA-1#

A:SetupCLI# show router pim interface detail
=====
PIM Interface int1
=====
Interface : int1
Admin Status : Up
DR : 10.1.1.1
BSM RA Check : Disabled
Hello Interval : 30
Multicast Senders : auto
J/P Tracking Admin : Disabled
Auto-created : No
Sticky-DR : Disabled
Max Groups Allowed : 0
Num Groups : 0
Oper Status : Up
Oper DR Priority : 1
Cfg DR Priority : 1
Time for next hello: 0d 00:00:23
Hello Multiplier : 35
J/P Tracking Oper : Disabled
Improved Assert : Enabled
Sticky-DR Priority : N/A
Max Groups Till Now: 0
Bfd Enabled : No
=====
PIM Interface sender
=====
Interface : sender
Admin Status : Up
DR : 11.1.1.1
Oper Status : Up
Oper DR Priority : 1
=====
A:SetupCLI#

```

## neighbor

**Syntax** `neighbor [ip-address | ip-int-name [address ip-address]] [detail] [family]`

**Context** show>router>pim

**Description** This command displays PIM neighbor information.

This can be important if an interface has more than one adjacency. For example, a LAN-interface configuration with three routers connected and all are running PIM on their LAN interfaces. These routers then have two adjacencies on their LAN interface, each with different neighbors. If the **address address** parameter is not defined in this example, then the **show** command output would display two adjacencies.

**Parameters** **neighbor ip-int-name** — Only displays the interface information associated with the specified IP interface name.

**neighbor ip-address** — Only displays the interface information associated with the specified IP address.

**address ip-address** — The ip-address of the neighbor, on the other side of the interface.

**detail** — Displays detailed neighbor information.

**family** — Displays either IPv4 or IPv6 information for the specified neighbor.

**Output** **PIM Neighbor Output** — The following table provides PIM neighbor field descriptions.

| Label            | Description                                                                                                                                                                                                                    |
|------------------|--------------------------------------------------------------------------------------------------------------------------------------------------------------------------------------------------------------------------------|
| Interface        | Displays the neighbor's interface name.                                                                                                                                                                                        |
| Nbr DR Priority  | Displays the value of the neighbor's DR priority which is received in the hello message.                                                                                                                                       |
| Nbr Address      | Displays the neighbor's address.                                                                                                                                                                                               |
| Up Time          | Displays the time since this PIM neighbor (last) became a neighbor of the local router.                                                                                                                                        |
| Expiry Time      | Displays the minimum time remaining before this PIM neighbor will be aged out.<br>0 — Means that this neighbor will never be aged out. This happens when the PIM neighbor sends a Hello message with holdtime set to '0xffff'. |
| Hold Time        | Displays the value of the hold time present in the hello message.                                                                                                                                                              |
| DR Priority      | Displays the value of the neighbor's DR priority which is received in the hello message.                                                                                                                                       |
| Tracking Support | Displays whether the T bit in the LAN prune delay option was present in the hello message. This indicates the neighbor's capability to disable join message suppression.                                                       |
| LAN Delay        | Displays the value of the LAN delay field present in the hello message received from the neighbor.                                                                                                                             |

| Label               | Description (Continued)                                                                                                                                                                                                                                                                                                                                                  |
|---------------------|--------------------------------------------------------------------------------------------------------------------------------------------------------------------------------------------------------------------------------------------------------------------------------------------------------------------------------------------------------------------------|
| Gen Id              | Displays a randomly generated 32-bit value that is regenerated each time PIM forwarding is started or restarted on the interface, including when the router itself restarts. When a hello message with a new GenID is received from a neighbor, any old hello information about that neighbor is discarded and superseded by the information from the new hello message. |
| Override Intvl (ms) | Displays the value of the override interval present in the Hello message.                                                                                                                                                                                                                                                                                                |

### Sample Output

```
ALA-1# show router pim neighbor
=====
PIM Neighbors
=====
Interface Nbr DR Nbr Address Up Time Expiry Time Hold
 Priority

ip-10.1.7.1 5 10.1.7.7 0d 00:10:39 0d 00:01:36 105
ip-10.1.2.1 5 10.1.2.2 0d 00:10:39 0d 00:01:35 105
ip-100.111.1.1 3 100.111.1.2 0d 00:09:31 0d 00:01:15 105

Neighbors : 3
=====
ALA-1#

ALA-1# show router pim neighbor detail
=====
PIM Neighbor
=====
Interface : ip-10.1.7.1
Neighbor Addr : 10.1.7.7 DR Priority : 5
Tracking Support : No LAN Delay(ms) : 500
Gen Id : 26470 Override Intvl(ms) : 2500
Up Time : 0d 00:10:41 Expiry Time : 0d 00:01:34
Hold Time(sec) : 105

=====
PIM Neighbor
=====
Interface : ip-10.1.2.1
Neighbor Addr : 10.1.2.2 DR Priority : 5
Tracking Support : No LAN Delay(ms) : 500
Gen Id : 37928 Override Intvl(ms) : 2500
Up Time : 0d 00:10:42 Expiry Time : 0d 00:01:33
Hold Time(sec) : 105

=====
PIM Neighbor
=====
```

## Show Router PIM Commands

```

Interface : ip-100.111.1.1
Neighbor Addr : 100.111.1.2 DR Priority : 3
Tracking Support : No LAN Delay(ms) : 500
Gen Id : 742098371 Override Intvl(ms) : 2500
Up Time : 0d 00:09:33 Expiry Time : 0d 00:01:43
Hold Time(sec) : 105

```

```

Neighbors : 3
=====
ALA-1#

```

### rp

**Syntax** `rp ip-address`

**Context** `show>router>pim`

**Description** This command displays the rendezvous point (RP) set information built by the router.

**Parameters** *ip-address* — Specifies the IP address of the RP.

**Output** **PIM Neighbor Output** — The following table provides PIM neighbor field descriptions.

| Label         | Description                                                                                                 |
|---------------|-------------------------------------------------------------------------------------------------------------|
| Group Address | Displays the multicast group address of the entry.                                                          |
| RP Address    | Displays the address of the Rendezvous Point (RP).                                                          |
| Type          | Specifies whether the entry was learned through the Bootstrap mechanism or if it was statically configured. |
| Priority      | Displays the priority for the specified group address. The higher the value, the higher the priority.       |
| Holdtime      | Displays the value of the hold time present in the BSM message.                                             |

### Sample Output

```

A:ALA-1# show router pim rp
=====
PIM RP Set
=====
Group Address RP Address Type Priority Holdtime

224.0.0.0/4 200.200.200.4 Dynamic 192 150
 10.1.7.1 Static 1 N/A

Group Prefixes : 1
=====
A:ALA-1#

```

```

A:ALA-1# show router pim rp 10.1.7.1

```

```

=====
PIM RP Set
=====
Group Address RP Address Type Priority Holdtime

224.0.0.0/4 10.1.7.1 Static 1 N/A

Group Prefixes : 1
=====
A:ALA-1#

```

## rp-hash

**Syntax** `rp-hash grp-ip-address`

**Context** `show>router>pim`

**Description** This command hashes the RP for the specified group from the RP set.

**Parameters** `grp-ip-address` — Displays specific multicast group addresses.

**Output** **PIM RP-Hash Output** — The following table provides RP-Hash output field descriptions.

| Label         | Description                                                                                                 |
|---------------|-------------------------------------------------------------------------------------------------------------|
| Group Address | Displays the multicast group address of the entry.                                                          |
| RP Address    | Displays the address of the Rendezvous Point (RP).                                                          |
| Type          | Specifies whether the entry was learned through the Bootstrap mechanism or if it was statically configured. |

### Sample Output

```

A:ALA-1# show router pim rp-hash 228.101.0.0
=====
PIM Group-To-RP mapping
=====
Group Address RP Address Type

228.101.0.0 200.200.200.4 Bootstrap
=====
A:ALA-1#

```

```

A:ALA-1# show router pim rp-hash 228.101.0.6
=====
PIM Group-To-RP mapping
=====
Group Address RP Address Type

228.101.0.6 200.200.200.4 Bootstrap
=====
A:ALA-1#

```

statistics

**Syntax** `statistics [ip-int-name | mt-int-name | ip-address] [family]`

**Context** show>router>pim

**Description** This command displays statistics for a particular PIM instance.

**Parameters** *ip-int-name* — Only displays the interface information associated with the specified IP interface name.  
*ip-address* — Only displays the interface information associated with the specified IP address.  
*family* — Displays either IPv4 or IPv6 information.

**Output** **PIM Statistics Output** — The following table provides PIM statistics output field descriptions.

| Label          | Description                                                                                                                                                                                                                                                                                                                                                                                                                                                                                                                                                                                                                                                                                                                                                                                                                                                                                                                                                                                            |
|----------------|--------------------------------------------------------------------------------------------------------------------------------------------------------------------------------------------------------------------------------------------------------------------------------------------------------------------------------------------------------------------------------------------------------------------------------------------------------------------------------------------------------------------------------------------------------------------------------------------------------------------------------------------------------------------------------------------------------------------------------------------------------------------------------------------------------------------------------------------------------------------------------------------------------------------------------------------------------------------------------------------------------|
| PIM Statistics | The section listing the PIM statistics for a particular interface.                                                                                                                                                                                                                                                                                                                                                                                                                                                                                                                                                                                                                                                                                                                                                                                                                                                                                                                                     |
| Message Type   | Displays the type of message.<br><br>Hello — Displays the number of PIM hello messages received or transmitted on this interface.<br><br>Join Prune — Displays the number of PIM join prune messages received or transmitted on this interface.<br><br>Asserts — Displays the number of PIM assert messages received or transmitted on this interface.<br><br>Register — Displays the number of register messages received or transmitted on this interface.<br><br>Null Register — Displays the number of PIM null register messages received or transmitted on this interface.<br><br>Register Stop — Displays the number of PIM register stop messages received or transmitted on this interface.<br><br>BSM — Displays the number of PIM Bootstrap messages (BSM) received or transmitted on this interface.<br><br>Candidate RP Adv — Displays the number of candidate RP advertisements.<br><br>Total Packets — Displays the total number of packets transmitted and received on this interface. |
| Received       | Displays the number of messages received on this interface.                                                                                                                                                                                                                                                                                                                                                                                                                                                                                                                                                                                                                                                                                                                                                                                                                                                                                                                                            |
| Transmitted    | Displays the number of multicast data packets transmitted on this interface.                                                                                                                                                                                                                                                                                                                                                                                                                                                                                                                                                                                                                                                                                                                                                                                                                                                                                                                           |
| Rx Errors      | Displays the total number of receive errors.                                                                                                                                                                                                                                                                                                                                                                                                                                                                                                                                                                                                                                                                                                                                                                                                                                                                                                                                                           |



| Label                             | Description (Continued)                                                                                                                                                                             |
|-----------------------------------|-----------------------------------------------------------------------------------------------------------------------------------------------------------------------------------------------------|
| General Inter-<br>face Statistics | The section listing the general PIM interface statistics.                                                                                                                                           |
| Register TTL<br>Drop              | Displays the number of multicast data packets which could not be encapsulated in Register messages because the time to live (TTL) was zero.                                                         |
| Tx Register MTU<br>Drop           | Displays the number of Bootstrap messages received on this interface but were dropped.                                                                                                              |
| Rx Invalid Reg-<br>ister          | Displays the number of invalid PIM register messages received on this interface.                                                                                                                    |
| Rx Neighbor<br>Unknown            | Displays the number of PIM messages (other than hello messages) which were received on this interface and were rejected because the adjacency with the neighbor router was not already established. |
| Rx Bad Checksum<br>Discard        | Displays the number of PIM messages received on this interface which were discarded because of bad checksum.                                                                                        |
| Rx Bad Encoding                   | Displays the number of PIM messages with bad encodings received on this interface.                                                                                                                  |
| Rx Bad Version<br>Discard         | Displays the number of PIM messages with bad versions received on this interface.                                                                                                                   |
| Rx CRP No Router<br>Alert         | Displays the number of candidate-rp advertisements (C-RP-Adv) received on this interface which had no router alert option set.                                                                      |
| Rx Invalid Join<br>Prune          | Displays the number of invalid PIM join prune messages received on this interface.                                                                                                                  |
| Rx Unknown PDU<br>Type            | Displays the number of packets received with an unsupported PIM type.                                                                                                                               |
| Join Policy<br>Drops              | Displays the number of times the join policy match resulted in dropping PIM join-prune message or one of the source group contained in the message.                                                 |
| Register Policy<br>Drops          | Displays the number of times the register policy match resulted in dropping PIM register message.                                                                                                   |
| Bootstrap Import<br>Policy Drops  | Displays the number of Bootstrap messages received on this interface but were dropped because of Bootstrap import policy.                                                                           |
| Bootstrap Export<br>Policy Drops  | Displays the number of Bootstrap messages that were not transmitted on this interface because of Bootstrap export policy.                                                                           |
| Source Group<br>Statistics        | The section listing the source group statistics.                                                                                                                                                    |
| (S,G)                             | Displays the number of entries in which the type is (S,G).                                                                                                                                          |

## Show Router PIM Commands

| Label     | Description (Continued)                                         |
|-----------|-----------------------------------------------------------------|
| (* ,G)    | Displays the number of entries in which the type is (*,G).      |
| (* ,*,RP) | Displays the number of entries in which the type is (*, *, rp). |

### Sample output

```
A:ALA-1# show router pim statistics
=====
PIM Statistics
=====
Message Type Received Transmitted Rx Errors

Hello 198 200 0
Join Prune 96 75 0
Asserts 0 0 0
Register 0 30 0
Null Register 0 160 0
Register Stop 180 0 0
BSM 34 76 0
Candidate RP Adv 0 0 0
Total Packets 546 541 0

General Interface Statistics

Register TTL Drop : 0
Tx Register MTU Drop : 0
Rx Invalid Register : 0
Rx Neighbor Unknown : 0
Rx Bad Checksum Discard : 0
Rx Bad Encoding : 0
Rx Bad Version Discard : 0
Rx CRP No Router Alert : 0
Rx Invalid Join Prune : 120
Rx Unknown PDU Type : 0
Join Policy Drops : 0
Register Policy Drops : 0
Bootstrap Import Policy Drops : 0
Bootstrap Export Policy Drops : 0

Source Group Statistics

(S,G) : 10
(* ,G) : 10
(* ,*,RP) : 0
=====
A:ALA-1#

A:ALA-1# show router pim statistics 10.1.7.1
=====
PIM Interface 10.1.7.1 Statistics
=====
Message Type Received Transmitted Rx Errors

Hello 62 66 0
Join Prune 36 21 0
```

```

Asserts 0 0 0
Register 0 0 0
Null Register 0 0 0
Register Stop 0 0 0
BSM 33 3 0
Total Packets 134 90

```

```

General Interface Statistics

```

```

Register TTL Drop : 0
Tx Register MTU Drop : 0
Rx Invalid Register : 0
Rx Neighbor Unknown : 0
Rx Bad Checksum Discard : 0
Rx Bad Encoding : 0
Rx Bad Version Discard : 0
Rx CRP No Router Alert : 0
Rx Invalid Join Prune : 0
Rx Unknown PDU Type : 0
Join Policy Drops : 0
Register Policy Drops : 0
Bootstrap Import Policy Drops : 0
Bootstrap Export Policy Drops : 0

```

```

Interface Source Group Statistics

```

```

(S,G) : 9
(*,G) : 0
(*,*,RP) : 0

```

```
=====
A:ALA-1#
```

```
A:ALA-1# show router pim statistics ip-10.1.7.1
```

```
=====
PIM Interface ip-10.1.7.1 Statistics
=====
```

| Message Type  | Received | Transmitted | Rx Errors |
|---------------|----------|-------------|-----------|
| Hello         | 63       | 67          | 0         |
| Join Prune    | 36       | 21          | 0         |
| Asserts       | 0        | 0           | 0         |
| Register      | 0        | 0           | 0         |
| Null Register | 0        | 0           | 0         |
| Register Stop | 0        | 0           | 0         |
| BSM           | 33       | 3           | 0         |
| Total Packets | 135      | 91          |           |

```

General Interface Statistics

```

```

Register TTL Drop : 0
Tx Register MTU Drop : 0
Rx Invalid Register : 0
Rx Neighbor Unknown : 0
Rx Bad Checksum Discard : 0
Rx Bad Encoding : 0
Rx Bad Version Discard : 0
Rx CRP No Router Alert : 0
Rx Invalid Join Prune : 0
Rx Unknown PDU Type : 0

```

## Show Router PIM Commands

```

Join Policy Drops : 0
Register Policy Drops : 0
Bootstrap Import Policy Drops : 0
Bootstrap Export Policy Drops : 0

Interface Source Group Statistics

(S,G) : 9
(*,G) : 0
(*,*,RP) : 0
=====
A:ALA-1#

```

## status

**Syntax** **status** [**detail**] [*family*]

**Context** show>router>pim

**Description** This command displays PIM status. The Oper Status reflects the combined operational status of IPv4/IPv6 PIM protocol status. If both are down, then Oper Status will be reflected as down. If IPv4 or IPv6 reflects up, the Oper Status will reflect up.

If PIM is not enabled, the following message appears:

```

A:NYC# show router pim status
MINOR: CLI PIM is not configured.
A:NYC#

```

**Parameters** **detail** — Displays detailed stasis information.

*family* — Displays either IPv4 or IPv6 information.

**Output** **PIM Status Output** — The following table provides PIM status output field descriptions.

| Label            | Description                                                                                           |
|------------------|-------------------------------------------------------------------------------------------------------|
| Admin State      | Displays the administrative status of PIM.                                                            |
| Oper State       | Displays the current operating state of this PIM protocol instance.                                   |
| BSR State        | Displays the state of the router with respect to the Bootstrap mechanism.                             |
| Address          | Displays the address of the elected Bootstrap router.                                                 |
| Expiry Time      | Displays the time remaining before the router sends the next Bootstrap message.                       |
| Priority         | Displays the priority of the elected Bootstrap router. The higher the value, the higher the priority. |
| Hash Mask Length | Displays the hash mask length of the Bootstrap router.                                                |
| Up Time          | Displays the time since the current E-BSR became the Bootstrap router.                                |

| Label            | Description (Continued)                                                                                                                                                                 |
|------------------|-----------------------------------------------------------------------------------------------------------------------------------------------------------------------------------------|
| RPF Intf towards | Displays the RPF interface towards the elected BSR. The value is zero if there is no elected BSR in the network.                                                                        |
| Address          | Displays the address of the candidate BSR router.                                                                                                                                       |
| Expiry Time      | Displays the time remaining before the router sends the next Bootstrap message.                                                                                                         |
| Priority         | Displays the priority of the Bootstrap router. The higher the value, the higher the priority.                                                                                           |
| Hash Mask Length | Displays the hash mask length of the candidate Bootstrap router.                                                                                                                        |
| Up Time          | Displays the time since becoming the Bootstrap router.                                                                                                                                  |
| Admin State      | Displays the administrative status of CRP.                                                                                                                                              |
| Oper State       | Displays the current operating state of the C-RP mechanism.                                                                                                                             |
| Address          | Displays the local RP address.                                                                                                                                                          |
| Priority         | Displays the CRP's priority for becoming a rendezvous point (RP). A 0 value is the highest priority.                                                                                    |
| Holdtime         | Displays the hold time of the candidate RP. It is used by the Bootstrap router to timeout the RP entries if it does not listen to another CRP advertisement within the holdtime period. |
| Policy           | Displays the PIM policies for a particular PIM instance.                                                                                                                                |
| Default Group    | Displays the default core group address.                                                                                                                                                |
| RPF Table        | Displays the route table used for RPF check.                                                                                                                                            |
| MC-ECMP-Hashing  | Displays if hash-based multicast balancing of traffic over ECMP links is enabled or disabled.                                                                                           |

### Sample Output

```
A:dut-d# show router pim status
=====
PIM Status
=====
Admin State : Up
Oper State : Up

BSR State : Accept Any

Elected BSR
 Address : None
 Expiry Time : N/A
 Priority : N/A
 Hash Mask Length : N/A
 Up Time : N/A
```

## Show Router PIM Commands

```
RPF Intf towards E-BSR : N/A

Candidate BSR
 Admin State : Down
 Oper State : Down
 Address : None
 Priority : 0
 Hash Mask Length : 30

Candidate RP
 Admin State : Down
 Oper State : Down
 Address : None
 Priority : 192
 Holdtime : 150

MC-ECMP-Hashing : Enabled

Policy : None

Default Group : 239.1.1.1

RPF Table : rtable-m
=====
A:dut-d#
```

## mld

**Syntax** mld

**Context** show>router

**Description** This command displays MLD related information.

## group

**Syntax** group [*grp-ipv6-address*]

**Context** show>router>mld

**Description** This command displays MLD group information.

**Parameters** *grp-ipv6-address* — Specifies the IPv6 group address.

**Values** ipv6-address x:x:x:x:x:x:x (eight 16-bit pieces)  
x:x:x:x:x:d.d.d.d  
x: [0..FFFF]H  
d: [0..255]D

**Output** \*A:SR7# show router mld group

```
=====
MLD Groups
=====
```

```

No Matching Entries
=====
*A:SR7#

*A:SR7# show router mld interface
=====
MLD Interfaces
=====
Interface Adm Oper Cfg/Opr Num Policy
 Querier Version Groups

Host4_Srcel_IPv6 Up Up 2/2 0 none
 FE80::216:4DFF:FED4:4D5B
Host1 Up Up 2/2 0 none
 FE80::216:4DFF:FED4:4D5B
Host2 Up Up 2/2 0 none
 FE80::216:4DFF:FE51:3728
Host3_vlan1 Up Up 2/2 0 none
 FE80::216:4DFF:FE51:3729
Host3_vlan2 Up Up 2/2 0 none
 FE80::216:4DFF:FE51:3729
Host3_vlan3 Up Up 2/2 0 none
 FE80::216:4DFF:FE51:3729
Host3_vlan4 Up Up 2/2 0 none
 FE80::216:4DFF:FE51:3729
Host3_vlan5 Up Up 2/2 0 none
*A:SR7# show router mld ssm-translate
=====
MLD SSM Tranlate Entries
=====
No Matching Entries
=====
*A:SR7#

*A:SR7# show router mld group
=====
MLD Groups
=====
(3FFE:100::2:100,FF05::1:1)
 Up Time : 0d 00:00:31
 Fwd List : Host1

(3FFE:100::2:100,FF05::1:2)
 Up Time : 0d 00:00:31
 Fwd List : Host1

(3FFE:100::2:100,FF05::1:3)
 Up Time : 0d 00:00:31
 Fwd List : Host1

(3FFE:100::2:100,FF05::1:4)
 Up Time : 0d 00:00:31
 Fwd List : Host1

(3FFE:100::2:100,FF05::1:5)
=====
*A:SR7#

```

## Show Router PIM Commands

```
*A:SR7# show router mld group ff05::1:1
=====
MLD Groups
=====
(3FFE:100::2:100,FF05::1:1)
 Up Time : 0d 00:00:40
 Fwd List : Host1

(*,G)/(S,G) Entries : 1
=====
*A:SR7#

*A:SR7# show router mld group ff05::1
=====
MLD Groups
=====
No Matching Entries
=====
```

## interface

**Syntax** `interface [ip-int-name | ip-address] [group] [grp-ipv6-address] [detail]`

**Context** `show>router>mld`

**Description** This command displays MLD interface information.

**Parameters** *ip-int-name*/*ip-address* — Specifies the IP interface name or interface address.

**group** *grp-ipv6-address* — Specifies the IPv6 group address.

**Values**

|              |                                     |
|--------------|-------------------------------------|
| ipv6-address | x:x:x:x:x:x:x (eight 16-bit pieces) |
|              | x:x:x:x:x:d.d.d.d                   |
|              | x: [0..FFFF]H                       |
|              | d: [0..255]D                        |

**detail** — Displays detailed information.

**Output**

```
*A:SR7# show router mld interface Host1 detail
=====
MLD Interface Host1
=====
Interface : Host1
Admin Status : Up
Oper Status : Up
Querier : FE80::216:4DFF:FED4:4D5B
Querier Up Time : 0d 00:02:18
Querier Expiry Time : N/A
Admin/Oper version : 2/2
Policy : none
Max Groups Allowed : No Limit
Query Interval : 0
Last List Qry Interval : 0
Time for next query: 0d 00:15:25
Num Groups : 6000
Max Groups Till Now: 6000
Query Resp Interval: 0
=====
MLD Group
```



```

Group Address : FF05::1:1
Last Reporter : FE80::1
Interface : Host1 Expires : N/A
Up Time : 0d 00:00:10 Mode : include
Vl Host Timer : Not running Type : dynamic
Compat Mode : MLD Version 2

Source
 Expires Type Fwd/Blk

3FFE:100::2:100
 0d 00:34:07 dynamic Fwd

MLD Group

Group Address : FF05::1:2
Last Reporter : FE80::1
Interface : Host1 Expires : N/A
Up Time : 0d 00:00:11 Mode : include
Vl Host Timer : Not running Type : dynamic
Compat Mode : MLD Version 2

Source
 Expires Type Fwd/Blk

3FFE:100::2:100
 0d 00:34:07 dynamic Fwd

MLD Group

Group Address : FF05::1:3
Last Reporter : FE80::1
Interface : Host1 Expires : N/A
Up Time : 0d 00:00:11 Mode : include
Vl Host Timer : Not running Type : dynamic
Compat Mode : MLD Version 2

Source
 Expires Type Fwd/Blk

3FFE:100::2:100
 0d 00:34:07 dynamic Fwd

MLD Group

Group Address : FF05::1:4
Last Reporter : FE80::1
Interface : Host1 Expires : N/A
Up Time : 0d 00:00:12 Mode : include
Vl Host Timer : Not running Type : dynamic
Compat Mode : MLD Version 2

Source
 Expires Type Fwd/Blk

3FFE:100::2:100
 0d 00:34:06 dynamic Fwd

```

## Show Router PIM Commands

```
MLD Group

Group Address : FF05::1:5
Last Reporter : FE80::1
Interface : Host1 Expires : N/A
Up Time : 0d 00:00:12 Mode : include
Vl Host Timer : Not running Type : dynamic
Compat Mode : MLD Version 2

Source
 Expires Type Fwd/Blk

3FFE:100::2:100
 0d 00:34:06 dynamic Fwd

```

## ssm-translate

**Syntax** **ssm-translate**

**Context** show>router>mld

**Description** This command displays the MLD SSM translate configuration.

## static

**Syntax** **static** [*ip-int-name* | *ip-address*]

**Context** show>router>mld

**Description** This command displays MLD static group/source configuration.

**Parameters** *ip-int-name*/*ip-address* — iSpecifies the IP interface name or IP address.

### Output

```
*A:SR7# show router mld static
=====
MLD Static Group Source
=====
Source Group
 Interface

No Matching Entries
=====
*A:SR7

*A:SR7# show router mld statistics
=====
MLD Interface Statistics
=====
Message Type Received Transmitted

Queries 0 640
Report Vl 0 0
```

```

Report V2 10 0
Dones 0 0

General Interface Statistics

Bad Length : 0
Bad Checksum : 0
Unknown Type : 0
Bad Receive If : 0
Rx Non Local : 0
Rx Wrong Version : 0
Policy Drops : 0
No Router Alert : 0
Rx Bad Encodings : 0
Rx Pkt Drops : 0
Local Scope Pkts : 10
Resvd Scope Pkts : 0

Source Group Statistics

(S,G) : 0
(*,G) : 0
=====
*A:SR7#

```

## statistics

**Syntax** **statistics** [*ip-int-name* | *ipv6-address*]

**Context** show>router>mld

**Description** This command displays MLD statistics.

*ip-int-name/ipv6-address* — iSpecifies the IP interface name or IPv6 address.

## status

**Syntax** **status**

**Context** show>router>mld

**Description** This command displays the MLD status.

**Output** \*A:SR7# show router mld status

```

=====
MLD Status
=====
Admin State : Up
Oper State : Up
Query Interval : 1024
Last Listener Query Interval : 1
Query Response Interval : 10
Robust Count : 2
=====

```

## Show Router PIM Commands

```
*A:SR7#

*A:SR7# show router mld interface Host1
=====
MLD Interface Host1
=====
Interface Adm Oper Cfg/Opr Num Policy
 Querier Version Groups

Host1 Up Up 2/2 5082 none
 FE80::216:4DFF:FED4:4D5B

Interfaces : 1
=====
*A:SR7#
```

## group

**Syntax** `group [group-name] [detail]`

**Context** `show>router>msdp`

**Description** This command displays information about MSDP groups.

**Parameters** *group-name* — Displays information about the specified group name. If no group-name is specified, information about all group names display.

**detail** — Displays detailed MSDP group information.

**Output** **MSDP Group Output** — The following table provides MSDP group field descriptions.

| Label            | Description                                                                                                                      |
|------------------|----------------------------------------------------------------------------------------------------------------------------------|
| Group Name       | Displays the MSDP group name.                                                                                                    |
| Mode             | Displays the groups of peers in a full mesh topology to limit excessive flooding of source-active messages to neighboring peers. |
| Act Srcs         | Displays the configured maximum number of active source messages that will be accepted by MSDP.                                  |
| Local Address    | Displays the local end of a MSDP session.                                                                                        |
| Admin State      | Displays the administrative state.                                                                                               |
| Receive Msg Rate | Displays rate that the messages are read from the TCP session.                                                                   |
| Receive Msg Time | Displays the time of MSDP messages that are read from the TCP session within the configured number of seconds.                   |
| Receive Msg Thd  | Displays the configured threshold number of MSDP messages can be processed before the MSDP message rate limiting function .      |
| SA Limit         | Displays the source-active limit.                                                                                                |

## Sample Output

```

*A:ALA-48>show>router>msdp# group
=====
MSDP Groups
=====
Group Name Mode Act Srcs Local Address

main Mesh-group None None
loop1 Mesh-group None None
loop2 Mesh-group None None
loop3 Mesh-group None None
loop4 Mesh-group None None
loop5 Mesh-group None None

Groups : 6
=====
*A:ALA-48>show>router>msdp#

*A:ALA-48>show>router>msdp# group test
=====
MSDP Groups
=====
Group Name Mode Act Srcs Local Address

test Mesh-group 50000 10.10.10.103

Groups : 1
=====
*A:ALA-48>show>router>msdp#

*A:ALA-48>show>router>msdp# group test detail
=====
MSDP Groups
=====
Group Name : test

Local Address : 10.10.10.103
Admin State : Up
Receive Msg Rate : None
Receive Msg Time : None
Mode : Mesh-group
Export Policy : None Specified / Inherited
Import Policy : None Specified / Inherited
SA Limit : 50000

Groups : 1
=====
*A:ALA-48>show>router>msdp#

```

## Show Router PIM Commands

### peer

**Syntax** `peer [ip-address] [group group-name] [detail]`

**Context** `show>router>msdp`

**Description** This command displays information about an MSDP peer.

**Parameters** *ip-address* — Displays information about the specified IP address. If no IP address specified, information about all MSDP IP addresses display.

*group group-name* — Displays information about the specified group name. If no *group-name* is specified, information about all MSDP peers display.

*detail* — Displays detailed MSDP peer information.

**Output** **MSDP Peer Output** — The following table provides MSDP field descriptions.

| Label             | Description                                                 |
|-------------------|-------------------------------------------------------------|
| Peer              | Displays the IP address of the peer.                        |
| Local Address     | Displays the local IP address.                              |
| State             | Displays the current state of the peer.                     |
| Last State Change | Displays the date and time of the peer's last state change. |
| SA Learn          | The number of SAs learned through a peer.                   |

### Sample Output

```
A:ALA-48# show router msdp peer
=====
MSDP Peers
=====
Peer Local Address State Last State Change SA Learnt

10.20.1.1 10.20.1.6 Established 08/30/2002 03:22:13 1008

Peers : 1
=====
A:ALA-48#
```

```
A:ALA-48# show router msdp peer detail
=====
MSDP Peers

Peer Address : 10.20.1.1

Group Name : None
Local Address : 10.20.1.6
Last State Change : 08/30/2002 03:22:13 Last Act Src Limit : N/A
Peer Admin State : Up Default Peer : No
Peer Connect Retry : 0 State : Established
```

```

SA accepted : 1008 SA received : 709
State timer expires: 18 Peer time out : 62
Active Source Limit: None Receive Msg Rate : 0
Receive Msg Time : 0 Receive Msg Thd : 0
Auth Status : Disabled Auth Key : None
Export Policy : None Specified / Inherited
Import Policy : None Specified / Inherited

```

```

Peers : 1
=====
```

```
A:ALA-48#
```

## SOURCE

**Syntax** **source** [*ip-address/mask*] [**type** {**configured** | **dynamic** | **both**}] [**detail**]

**Context** show>router>msdp

**Description** This command displays the discovery method for this multicast source.

**Parameters** **configured** — Displays user-created sources.

**dynamic** — Displays dynamically created sources.

**both** — Displays both user-configured and dynamically created sources.

**detail** — Displays detailed MSDP source information.

**Output** **MSDP Source Output** — The following table provides MSDP source field descriptions.

| Label         | Description                                                                     |
|---------------|---------------------------------------------------------------------------------|
| Source        | Displays the IP address of the peer.                                            |
| Type          | Displays the type of peer.                                                      |
| SA limit      | Displays the local IP address.                                                  |
| State         | Displays the current state of the peer.                                         |
| Num excd      | Indicates the number of times the global active source limit has been exceeded. |
| Last exceeded | Displays the date and time of the peer's last state change.                     |

## source-active

**Syntax** **source-active** [**group** *ip-address* | **local** | **originator** *ip-address* | **peer** *ip-address* | **source** *ip-address* [{**group** *ip-address* **source** *ip-address*}] [**detail**]

**Context** show>router>msdp

**Description** This command displays source active messages accepted by MSDP.

## Show Router PIM Commands

- Parameters**
- group** *ip-address* — Displays information about the specified group IP address.
  - local** — Displays information about local source-active messages.
  - originator** *ip-address* — Displays information about the specified originator IP address.
  - peer** *ip-address* — Displays information about the specified peer IP address.
  - source** *ip-address* — Displays information about the specified source IP address.
  - group** *ip-address* — Displays information about the specified group IP address.
  - detail** — Displays detailed MSDP source-active information.

**Output** **MSDP Source-Active Output** — The following table provides MSDP source-active field descriptions.

| Label        | Description                                                       |
|--------------|-------------------------------------------------------------------|
| Grp Address  | Displays the IP address of the group.                             |
| Src Address  | Displays the IP address of the source.                            |
| Origin RP    | Displays the origination rendezvous point (RP) address.           |
| Peer Address | Displays the address of the peer.                                 |
| State Timer  | The time-out value. If the value reaches zero, the SA is removed. |

### Sample Output

```
A:ALA-48# show router msdp source-active
=====
MSDP Source Active Info
=====
Grp Address Src Address Origin RP Peer Address State Timer

228.100.0.0 100.112.1.2 10.20.1.1 10.20.1.1 69
228.100.0.1 100.112.1.2 10.20.1.1 10.20.1.1 69
228.100.0.2 100.112.1.2 10.20.1.1 10.20.1.1 69
228.100.0.3 100.112.1.2 10.20.1.1 10.20.1.1 69
228.100.0.4 100.112.1.2 10.20.1.1 10.20.1.1 69
228.100.0.5 100.112.1.2 10.20.1.1 10.20.1.1 69
228.100.0.6 100.112.1.2 10.20.1.1 10.20.1.1 69
228.100.0.7 100.112.1.2 10.20.1.1 10.20.1.1 69
228.100.0.8 100.112.1.2 10.20.1.1 10.20.1.1 69
228.100.0.9 100.112.1.2 10.20.1.1 10.20.1.1 69

MSDP Source Active : 10
=====
A:ALA-48#

A:ALA-48# show router msdp source-active detail
=====
MSDP Source Active
=====
Group Address : 228.100.0.0 Source Address : 100.112.1.2
Origin RP : 10.20.1.1 Peer Address : 10.20.1.1
State Timer : 64 Up Time : 3d 01:44:25
```



```

Group Address : 228.100.0.1 Source Address : 100.112.1.2
Origin RP : 10.20.1.1 Peer Address : 10.20.1.1
State Timer : 64 Up Time : 48d 18:22:29
Group Address : 228.100.0.2 Source Address : 100.112.1.2
Origin RP : 10.20.1.1 Peer Address : 10.20.1.1
State Timer : 64 Up Time : 48d 18:22:29
Group Address : 228.100.0.3 Source Address : 100.112.1.2
Origin RP : 10.20.1.1 Peer Address : 10.20.1.1
State Timer : 64 Up Time : 48d 18:22:29
Group Address : 228.100.0.4 Source Address : 100.112.1.2
Origin RP : 10.20.1.1 Peer Address : 10.20.1.1
State Timer : 64 Up Time : 48d 18:22:29
Group Address : 228.100.0.5 Source Address : 100.112.1.2
Origin RP : 10.20.1.1 Peer Address : 10.20.1.1
State Timer : 64 Up Time : 48d 18:22:29
Group Address : 228.100.0.6 Source Address : 100.112.1.2
Origin RP : 10.20.1.1 Peer Address : 10.20.1.1
State Timer : 64 Up Time : 48d 18:22:29
Group Address : 228.100.0.7 Source Address : 100.112.1.2
Origin RP : 10.20.1.1 Peer Address : 10.20.1.1
State Timer : 64 Up Time : 48d 18:22:29
Group Address : 228.100.0.8 Source Address : 100.112.1.2
Origin RP : 10.20.1.1 Peer Address : 10.20.1.1
State Timer : 64 Up Time : 48d 18:22:29
Group Address : 228.100.0.9 Source Address : 100.112.1.2
Origin RP : 10.20.1.1 Peer Address : 10.20.1.1
State Timer : 64 Up Time : 48d 18:22:29

```

```

MSDP Source Active : 10
=====
```

```
A:ALA-48#
```

## source-active-rejected

**Syntax** **source-active-rejected** [**peer-group name**] [**group ip-address**] [**source ip-address**] [**originator ip-address**] [**peer ip-address**]

**Context** show>router>msdp

**Description** This command displays source active messages rejected by MSDP.

**Parameters** **group ip-address** — Displays information about the peer group name of the Source Active entry that is rejected.

**local** — Displays information about local source-active messages.

**originator ip-address** — Displays information about the specified originator IP address.

**peer ip-address** — Displays information about the peer from which this rejected source active entry was last received.

**source ip-address** — Displays information about the source address of the source active entry that is rejected.

**group ip-address** — Displays information about the specified group IP address.

**MSDP Source-Active Output** — The following table provides MSDP source-active field descriptions.

| Label         | Description                                                   |
|---------------|---------------------------------------------------------------|
| Grp Address   | Displays the IP address of the group.                         |
| Src Address   | Displays the IP address of the source.                        |
| Origin RP     | Displays the origination rendezvous point (RP) address.       |
| Peer Address  | Displays the address of the peer.                             |
| Reject Reason | Displays the reason why this source active entry is rejected. |

**Sample Output**

```
*A:ALA-48# show router msdp source-active-rejected
=====
MSDP Source Active Rejected Info
=====
Grp Address Src Address Origin RP Peer Address Reject Reason

228.100.0.1 110.0.0.1 10.20.0.1 20.0.0.1 Import Policy
228.100.0.2 110.0.0.2 10.20.0.2 20.0.0.2 Export Policy
228.100.0.3 110.0.0.3 10.20.0.3 20.0.0.3 RPF Failure
228.100.0.4 110.0.0.4 10.20.0.4 20.0.0.4 Limit Exceeded
228.100.0.5 110.0.0.5 10.20.0.5 20.0.0.5 Limit Exceeded
228.100.0.6 110.0.0.6 10.20.0.6 20.0.0.6 Limit Exceeded
228.100.0.7 110.0.0.7 10.20.0.7 20.0.0.7 Limit Exceeded

SA Rejected Entries : 7
=====
*A:ALA-48#
```

statistics

**Syntax** `statistics [peer ip-address]`

**Context** `show>router>msdp`

**Description** This command displays statistics information related to a MSDP peer.

**Parameters** `peer ip-address` — Displays information about the specified peer IP address

**Output** **MSDP Statistics Output** — The following table provides MSDP statistics field descriptions.

| Label             | Description                                                    |
|-------------------|----------------------------------------------------------------|
| Last State Change | Displays the date and time the peer state changed.             |
| RPF Failures      | Displays the number of reverse path forwarding (RPF) failures. |
| SA Msgs Sent      | Displays the number of source-active messages sent.            |

| Label               | Description (Continued)                                          |
|---------------------|------------------------------------------------------------------|
| SA req. Msgs Sent   | Displays the number of source-active request messages sent.      |
| SA res. Msgs Sent   | Displays the number of source-active response messages sent.     |
| KeepAlive Msgs Sent | Displays the number of keepalive messages sent.                  |
| Unknown Msgs Sent   | Displays the number of unknown messages received.                |
| Last message Peer   | Displays the time the last message was received from the peer.   |
| Remote Closes       | Displays the number of times the remote peer close.              |
| SA Msgs Recvd       | Displays the number of source-active messages received.          |
| SA req. Msgs Recvd  | Displays the number of source-active request messages received.  |
| SA res. Msgs Recvd  | Displays the number of source-active response messages received. |
| KeepAlive Msgs Recd | Displays the number of keepalive messages received.              |
| Error Msgs Recvd    | Displays the number of unknown messages received.                |

### Sample Output

```
A:ALA-48# show router msdp statistics
=====
MSDP Statistics
=====
Glo ActSrc Lim Excd: 0

Peer Address : 10.20.1.1

Last State Change : 0d 11:33:16 Last message Peer : 0d 00:00:17
RPF Failures : 0 Remote Closes : 0
SA Msgs Sent : 0 SA Msgs Recvd : 709
SA req. Msgs Sent : 0 SA req. Msgs Recvd : 0
SA res. Msgs Sent : 0 SA res. Msgs Recvd : 0
KeepAlive Msgs Sent: 694 KeepAlive Msgs Recd: 694
Unknown Msgs Sent : 0 Error Msgs Recvd : 0

Peers : 1
=====
A:ALA-48#
```

## Show Router PIM Commands

### status

**Syntax** **status**

**Context** show>router>msdp

**Description** This command displays MSDP status information.

**Output** **MSDP Status Output** — The following table provides MSDP status field descriptions.

| Label              | Description                                                                                                                                                               |
|--------------------|---------------------------------------------------------------------------------------------------------------------------------------------------------------------------|
| Admin State        | Displays the administrative state.                                                                                                                                        |
| Local Address      | Displays the local IP address.                                                                                                                                            |
| Active Src Limit   | Displays the active source limit.                                                                                                                                         |
| Act Src Lim Excd   | Displays the active source limit which has been exceeded.                                                                                                                 |
| Num. Peers         | Displays the number of peers.                                                                                                                                             |
| Num. Peers Estab   | Displays the number of peers established.                                                                                                                                 |
| Num. Source Active | Displays the number of active sources.                                                                                                                                    |
| Policies           | The policy to export source active state from the source active list into MSDP.                                                                                           |
| Data Encapsulation | The rendezvous point (RP) using MSDP to encapsulate multicast data received in MSDP register messages inside forwarded MSDP source-active messages - enabled or disabled. |
| Rate               | The receive message rate.                                                                                                                                                 |
| Time               | The receive message time.                                                                                                                                                 |
| Threshold          | The number of MSDP messages that can be processed before the MSDP message rate limiting function is activated.                                                            |
| RPF Table          | The name of the reverse path forwarding table.                                                                                                                            |
| Last mdsdp Enabled | The time the last MDSP was triggered.                                                                                                                                     |

### Sample Output

```
A:ALA-48# show router msdp status
=====
MSDP Status
=====
Admin State : Up
Local Address : None
Global Statistics
Active Src Limit : None
```

```

Act Src Lim Excd : 0
Num. Peers : 1
Num. Peers Estab : 1
Num. Source Active : 10
Policies : None
Data Encapsulation : Enabled
Receive Msg Rate
Rate : 0
Time : 0
Threshold : 0
Last Msdp Enabled : 08/30/2002 03:21:43
=====
A:ALA-48#

```

## mcac

**Syntax** **mcac**

**Context** show>router

**Description** This command enables the context to display multicast CAC related information.

## policy

**Syntax** **policy** [*policy-name* [**bundle** *bundle-name*] [**protocol** *protocol-name*] [**interface** *if-name*] [**detail**]]

**Context** show>router>mcac

**Description** This command displays MCAC policy information.

**Parameters** *policy-name* — Specifies an existing multicast CAC (MCAC) policy name.

**bundle** *bundle-id* — Specifies an existing multicast bundle name.

**protocol** *protocol-name* — specifies an applicable protocol to display.

**Values** igmp, pim, igmpSnpG

**interface** *if-name* — Specifies an interface name to display.

**detail** — Displays detailed information.

### Sample Output

```

*A:ALA-48>show>router>mcac# policy
=====
Multicast CAC Policies
=====
Policy Description

btv_fr foreign TV offering
btv_vl eastern TV offering
policy1 this is policy1

```

## Show Router PIM Commands

```
policy2 this is policy 2

Policies : 4
=====
*A:ALA-48>show>router>mcac#

*A:ALA-48>show>router>mcac# policy btv_fr
=====
Multicast CAC policy
=====
Policy : btv_fr
Description : foreign TV offering
Default Action : discard
Bundle(s) : FOR
=====
*A:ALA-48>show>router>mcac#
```

### statistics

**Syntax** **statistics policy** *policy-name* [**bundle** *bundle-name*] [**protocol** *protocol-name*] [**interface** *if-name*] **statistics**

**Context** show>router>mcac

**Description** This command displays MCAC statistics.

**Parameters** *policy-name* — Specifies an existing multicast CAC (MCAC) policy name.  
**bundle** *bundle-id* — Displays statistics for the specified existing multicast bundle name.  
**protocol** *protocol-name* — Displays statistics for the specified applicable protocol.  
**Values** igmp, pim, igmpSnpg  
**interface** *if-name* — Displays statistics for the specified interface name.  
**detail** — Displays detailed information.

### mvpn

**Syntax** **mvpn**

**Context** show>router *router-instance*

**Description** This command displays Multicast VPN related information. The router instance must be specified.

#### Sample Output

```
*A:Dut-C# show router 1 mvpn
=====
MVPN 1 configuration data
=====
```

```

signaling : Bgp auto-discovery : Enabled
UMH Selection : Highest-Ip intersite-shared : Enabled
vrf-import : N/A
vrf-export : N/A
vrf-target : target:1:1
C-Mcast Import RT : target:10.20.1.3:2

ipmsi : pim-asm 224.1.1.1
admin status : Up three-way-hello : N/A
hello-interval : N/A hello-multiplier : 35 * 0.1
tracking support : Disabled Improved Assert : N/A

spmsi : pim-ssm 225.0.0.0/32
join-tlv-packing : N/A
data-delay-interval : 3 seconds
data-threshold : 224.0.0.0/4 --> 1 kbps
=====

```

## tunnel-table

**Syntax** `tunnel-table [ip-address [/mask]] [protocol | sdp sdp-id]`  
**tunnel-table [summary]**

**Context** show>router

**Description** This command displays tunnel table information.

**Parameters** *protocol* — Specifies the protocol.

**Values** bgp | ldp | rsvp | sdp

*sdp-id* — Specifies the SDP ID.

**Values** 1..17407

**Output** \*A:Dut-C# show router tunnel-table sdp 17407

```

=====
Tunnel Table (Router: Base)

=====
Destination Owner Encap TunnelId Pref Nexthop Metric

127.0.68.0/32 sdp MPLS 17407 5 127.0.68.0 0
=====

```

---

## Clear Commands

### database

**Syntax** **database** [**interface** *ip-int-name*|*ip-address*] **group** *grp-ip-address* [**source** *src-ip-address*]  
**database grp-interface** *interface-name* [ **fwd-service** *service-id*]  
**database** [**interface** *ip-int-name*|*ip-address*] **group** *grp-ip-address* **source** *src-ip-address*  
**database host** [*ip-address*]  
**database interface** *ip-int-name*|*ip-address* [**group** *grp-ip-address*] [**source** *src-ip-address*]

**Context** clear>router>igmp

**Description** This command clears IGMP or PIM database statistics on a specified interface or IP address.

**Parameters** **interface** *ip-int-name* — Clears the IGMP or PIM database on the specified interface.  
**interface** *ip-address* — Clears the IGMP or PIM database on the specified IP address.  
**group** *group-ip-address* — Clears the multicast group address(ipv4/ipv6) or zero in the specified address group.  
**source** *ip-address* — Clears the IGMP or PIM database from the specified source IP address.

### database

**Syntax** **database** [**interface** *ip-int-name*|*mt-int-name*|*int-ip-address*] [**group** *grp-ip-address* [**source** *ip-address*]] [*family*]

**Context** clear>router>pim

**Description** This command clears IGMP or PIM database statistics on a specified interface or IP address.

**Parameters** **interface** *ip-int-name* — Clears the IGMP or PIM database on the specified interface.  
**interface** *mt-int-name* — Clears the default core group address of the Multicast Distribution Tree (MDT) for the VPRN instance. The Multicast Tunnel (MT) interface for a VPRN is created when this object is set to a valid group address.  
**Syntax:** *vprn-id-mt-grp-ip-address*  
**interface** *ip-address* — Clears the IGMP or PIM database on the specified IP address.  
**group** *group-ip-address* — Clears the multicast group address(ipv4/ipv6) or zero in the specified address group.  
**source** *ip-address* — Clears the IGMP or PIM database from the specified source IP address.  
*family* — Clears either IPv4 or IPv6 information.  
*mpls-if-name* — Clears the MPLS interface name.



**Syntax:** *mpls-if-index*

## statistics

**Syntax** **statistics** [**interface** *ip-int-name* | *ip-address*]

**Context** clear>router>igmp

**Description** This command clears IGMP statistics on a specified interface or IP address. Note that interface and group/source cannot be specified at the same time.

**Parameters** **interface** *ip-int-name* — Clears IGMP statistics on the specified interface.  
**interface** *ip-address* — Clears IGMP statistics on the specified IP address.  
**interface** *mt-int-name* — Clears the default core group address of the Multicast Distribution Tree (MDT) for the VPRN instance. The Multicast Tunnel (MT) interface for a VPRN is created when this object is set to a valid group address.

**Syntax:** *vprn-id-mt-grp-ip-address*

## s-pmsi

**Syntax** **s-pmsi** [*mdSrcAddr*] [*mdGrpAddr*] [*vprnSrcAddr* *vprnGrpAddr*]

**Context** clear>router>pim

**Description** This command clears PIM selective provider multicast service interface cache.

**Parameters** *mdSrcAddr* — Clears the specified source address used for Multicast Distribution Tree (MDT).  
*mdGrpAddr* — Clears the specified group address used for Multicast Distribution Tree (MDT).  
*vprnSrcAddr* — Clears the specified source address of the multicast sender.  
*vprnGrpAddr* — Clears the specified multicast group address.

## statistics

**Syntax** **statistics** [[[**interface** *ip-int-name* | *ip-address* | *mt-int-name*]]] [[**group** *grp-ip-address* [**source** *ip-address*]]] [*family*]

**Context** clear>router>pim

**Description** This command clears PIM statistics on a specified interface or IP address. Note that an interface and group or source cannot be specified at the same time.

**Parameters** **interface** *ip-int-name* — Clears PIM statistics on the specified interface.  
**interface** *ip-address* — Clears PIM statistics on the specified IP address.

## Clear Commands

**interface** *mt-int-name* — Clears the default core group address of the Multicast Distribution Tree (MDT) for the VPRN instance. The Multicast Tunnel (MT) interface for a VPRN is created when this object is set to a valid group address.

**syntax:** *vprn-id-mt-grp-ip-address*

**group** *grp-ip-address* — When only the group address is specified and no source is specified, (\*,G) statistics are cleared. When the group address is specified along with the source address, then the (S,G) statistics are reset to zero.

**source** *ip-address* — When the source address is specified along with the group address, then the (S,G) statistics are reset to zero.

*family* — Clears either IPv4 or IPv6 information.

## version

**Syntax** **version** [**interface** *ip-int-name* | *ip-address*]

**Context** clear>router>igmp

**Description** This command clears IGMP statistics on a specified interface or IP address.

**Parameters** **interface** *ip-int-name* — Clears IGMP or PIM statistics on the specified interface.  
**interface** *ip-address* — Clears IGMP or PIM statistics on the specified IP address.

## mld

**Syntax** **mld**

**Context** clear>router

**Description** This command enables the context to clear and reset Multicast Listener Discovery (MLD) entities.

## database

**Syntax** **database** [**interface** *ip-int-name*|*ipv6-address*] [**group** *ip-address* [**source** *ip-address*]]

**Context** clear>router>mld

**Description** This command clears Multicast Listener Discovery (MLD) database parameters.

**Parameters** **interface** *ip-int-name* — Clears database information for the specified Multicast Listener Discovery (MLD) interface name.  
**interface** *ipv6-address* — Clears database information for the specified Multicast Listener Discovery (MLD) interface IPv6 address.

**group *ip-address*** — Clears database information for the specified Multicast Listener Discovery (MLD) group IP address.

**source *ip-address*** — Clears database information for the specified Multicast Listener Discovery (MLD) source IP address.

## statistics

**Syntax** **statistics** [*ip-int-name*]*ipv6-address*]

**Context** clear>router>mld

**Description** This command clears Multicast Listener Discovery (MLD) statistics parameters.

**Parameters** *ip-int-name* — Clears statistics for the specified Multicast Listener Discovery (MLD) interface name.  
*ipv6-address* — Clears statistics for the specified Multicast Listener Discovery (MLD) IPv6 address.

## version

**Syntax** **version** [*ip-int-name*]*ip-address*]

**Context** clear>router>mld

**Description** This command clears Multicast Listener Discovery (MLD) version parameters.

**Parameters** *ip-int-name* — Clears version information for the specified Multicast Listener Discovery (MLD) interface name.  
*ip-address* — Clears version information for the specified Multicast Listener Discovery (MLD) IP address.

## msdp

**Syntax** **msdp**

**Context** clear>router

**Description** This command enables the context to clear and reset Multicast Source Discovery protocol (MSDP) entities and statistics.

## cache

**Syntax** **cache** [**peer** *ip-address*] [**group** *ip-address*] [**source** *ip-address*] [**originrp** *ip-address*]

**Context** clear>router>msdp

**Description** This command clears the MSDP cache.

## Clear Commands

- Parameters**
- peer** *ip-address* — Clears the cache of the IP address of the peer to which Multicast Source Discovery protocol (MSDP) source-active ( SA) requests for groups matching this entry's group range were sent.
  - group** *ip-address* — Clears the group IP address of the SA entry.
  - source** *ip-address* — Clears the source IP address of the SA entry.
  - originrp** *ip-address* — Clears the origin rendezvous point(RP) address type of the SA entry.

## statistics

- Syntax** **statistics** [**peer** *ip-address*]
- Context** clear>router>msdp
- Description** **peer** *ip-address* — Clears the statistics of the IP address of the peer to which Multicast Source Discovery Protocol (MSDP) source-active ( SA) requests for groups matching this entry's group range were sent.

## neighbor

- Syntax** **neighbor** [*ip-int-name* | *ip-address*] [*family*]
- Context** clear>router>pim
- Description** This command clears PIM neighbor data on a specified interface or IP address.
- Parameters**
- ip-int-name* — Clears PIM neighbor on the specified interface.
  - ip-address* — Clears PIM neighbor on the specified IP address.
  - family* — Clears either IPv4 or IPv6 information.

## igmp-snooping

- Syntax** **igmp-snooping**
- Context** clear>service>id
- Description** This command enables the context to clear IGMP snooping-related data.

## port-db

- Syntax** **port-db** {**sap** *sap-id* | **sdp** *sdp-id:vc-id*} [**group** *grp-address* [**source** *ip-address*]]
- Context** clear>service>id>igmp-snooping
- Description** Clears the information on the IGMP snooping port database.

**Parameters** **sap** *sap-id* — Clears IGMP snooping statistics matching the specified SAP ID and optional encapsulation value. The *sap-id* can be in one of the following formats:

| Encapsulation type | Syntax               | Example       |
|--------------------|----------------------|---------------|
| null               | port-id              | 1/1/3         |
| dot1q              | port-id :qtag1       | 1/1/3:100     |
| qinq               | port-id :qtag1.qtag2 | 1/1/3:100.200 |

*qtag1*, *qtag2* — The encapsulation value on the specified port ID.

**Values** 0 — 4094

**sdp** *sdp-id* — Clears only IGMP snooping entries associated with the specified mesh SDP or spoke SDP. For a spoke SDP, the VC ID must be specified; for a mesh SDP, the VC ID is optional.

**Values** 1 — 17407

*vc-id* — The virtual circuit ID on the SDP ID for which to clear information.

**Default** For mesh SDPs only, all VC IDs

**Values** 1 — 4294967295

**group** *grp-address* — Clears IGMP snooping statistics matching the specified group address.

**source** *ip-address* — Clears IGMP snooping statistics matching one particular source within the multicast group.

## querier

**Syntax** **querier**

**Context** clear>service>id>igmp-snooping

**Description** Clears information on the IGMP snooping queriers for the VPLS service.

## statistics

**Syntax** **statistics** [**sap** *sap-id* | **sdp** *sdp-id:vc-id*]

**Context** clear>service>id>igmp-snooping

**Description** Clears IGMP snooping statistics for the VPLS service.

**Parameters** **sap** *sap-id* — Displays IGMP snooping statistics for a specific SAP. The *sap-id* can be in one of the following formats:

| Encapsulation type | Syntax               | Example       |
|--------------------|----------------------|---------------|
| null               | port-id              | 1/1/3         |
| dot1q              | port-id :qtag1       | 1/1/3:100     |
| qinq               | port-id :qtag1.qtag2 | 1/1/3:100.200 |

## Clear Commands

*qtag1, qtag2* — The encapsulation value on the specified port ID.

**Values** 0 — 4094

**sdp** *sdp-id* — Displays the IGMP snooping statistics for a specific spoke or mesh SDP.

**Values** 1 — 17407

*vc-id* — The virtual circuit ID on the SDP ID for which to display information.

**Default** For mesh SDPs only, all VC IDs

**Values** 1 — 4294967295

## pim-snooping

**Syntax** **pim-snooping**

**Context** clear>service>id

**Description** This command enables the context to clear PIM snooping information.

## database

**Syntax** **database** [[**sap** *sap-id* | **sdp** *sdp-id:vc-id*] [**group** *grp-ip-address*] [**source** *src-ip-address*]]

**Context** clear>service>id>pim-snooping

**Description** This command clears PIM snooping source group database information.

**Parameters** **sap** *sap-id* — Clears PIM snooping SAP information.

**sdp** *sdp-id* — Clears PIM snooping entries associated with the specified SDP. For a spoke SDP, the VC ID must be specified; for a mesh SDP, the VC ID is optional.

**Values** 1 — 17407

**group** *grp-address* — Clears PIM snooping information matching the specified group address.

**source** *ip-address* — Clears PIM snooping information matching one particular source within the multicast group.

## neighbor

**Syntax** **neighbor** [*ip-address* | **sap** *sap-id* | **sdp** *sdp-id:vc-id*]

**Context** clear>service>id>pim-snooping

**Description** This comand clears PIM snooping neighbor information.

**Parameters** *ip-address* — Clears IP address information.

**sap** *sap-id* — Clears PIM snooping SAP information.

**sdp** *sdp-id* — Clears PIM snooping entries associated with the specified SDP. For a spoke SDP, the VC ID must be specified; for a mesh SDP, the VC ID is optional.

**Values** 1 — 17407

## statistics

**Syntax** **statistics** [**sap** *sap-id* | **sdp** *sdp-id:vc-id*]

**Context** clear>service>id>pim-snooping

**Description** This command clears PIM snooping statistics for the specified SAP or SDP.

**Parameters** **sap** *sap-id* — Clears PIM snooping SAP information.

**sdp** *sdp-id* — Clears PIM snooping entries associated with the specified SDP. For a spoke SDP, the VC ID must be specified; for a mesh SDP, the VC ID is optional.

**Values** 1 — 17407

---

## Debug Commands

---

### Debug IGMP Commands

#### group-interface

**Syntax** [no] **group-interface** [fwd-service *service-id*] [*ip-int-name*]

**Context** debug>router>igmp

**Description** This command enables debugging for IGMP group-interface.  
The **no** form of the command disables debugging.

#### host

**Syntax** **host** [*ip-address*]  
**host** [fwd-service *service-id*] **group-interface** *ip-int-name*  
**no host** [*ip-address*]  
**no host** [fwd-service *service-id*] **group-interface** *ip-int-name*

**Context** debug>router>igmp

**Description** This command enables debugging for the IGMP host.  
The **no** form of the command disables debugging.

#### interface

**Syntax** [no] **interface** [*ip-int-name* | *ip-address*]

**Context** debug>router>igmp

**Description** This command enables debugging for IGMP interfaces.  
The **no** form of the command disables the IGMP interface debugging for the specifies interface name or IP address.

**Parameters** *ip-int-name* — Only displays the information associated with the specified IP interface name.  
*ip-address* — Only displays the information associated with the specified IP address.



## mcs

**Syntax** **mcs** [*ip-int-name*]  
**no mcs**

**Context** debug>router>igmp

**Description** This command enables debugging for IGMP multicast servers (MCS).  
 The **no** form of the command disables the IGMP interface debugging for the specifies interface name.

**Parameters** *ip-int-name* — Only displays the information associated with the specified IP interface name.

## misc

**Syntax** [**no**] **misc**

**Context** debug>router>igmp

**Description** This command enables debugging for IGMP miscellaneous.  
 The **no** form of the command disables the debugging.

**Sample Output**

```
A:ALA-CA# debug router 100 igmp misc
*A:ALA-CA# show debug
debug
 router "100"
 igmp
 misc
 exit
 exit
exit
*A:ALA-CA#
```

## packet

**Syntax** **packet** [query|v1-report|v2-report|v3-report|v2-leave] **host** *ip-address*  
**packet** [query|v1-report|v2-report|v3-report|v2-leave] [*ip-int-name*|*ip-address*]  
**no packet** [query|v1-report|v2-report|v3-report|v2-leave] [*ip-int-name*|*ip-address*]  
**no packet** [query|v1-report|v2-report|v3-report|v2-leave] **host** *ip-address*

**Context** debug>router>igmp

**Description** This command enables/disables debugging for IGMP packets.

**Parameters** **query** — Specifies to log the IGMP group- and source-specific queries transmitted and received on this interface.  
**v1-report** — Specifies to log IGMP V1 reports transmitted and received on this interface.

## Debug Commands

- v2-report** — Specifies to log IGMP V2 reports transmitted and received on this interface.
- v3-report** — Specifies to log IGMP V3 reports transmitted and received on this interface.
- v2-leave** — Specifies to log the IGMP Leaves transmitted and received on this interface.
- ip-int-name* — Only displays the information associated with the specified IP interface name.
- ip-address* — Only displays the information associated with the specified IP address.

---

## Debug PIM Commands

### adjacency

**Syntax** [no] adjacency

**Context** debug>router>pim

**Description** This command enables/disables debugging for PIM adjacencies.

### all

**Syntax** all [group *grp-ip-address*] [source *ip-address*] [detail]  
no all

**Context** debug>router>pim

**Description** This command enables/disables debugging for all the PIM modules.

**Parameters** **group** *grp-ip-address* — Debugs information associated with all PIM modules.

**Values** IPv4 or IPv6 address

**source** *ip-address* — Debugs information associated with all PIM modules.

**Values** IPv4 or IPv6 address

**detail** — Debugs detailed information on all PIM modules.

### assert

**Syntax** assert [group *grp-ip-address*] [source *ip-address*] [detail]  
no assert

**Context** debug>router>pim

**Description** This command enables/disables debugging for PIM assert mechanism.

**Parameters** **group** *grp-ip-address* — Debugs information associated with the PIM assert mechanism.

**Values** multicast group address (ipv4/ipv6)

**source** *ip-address* — Debugs information associated with the PIM assert mechanism.

**Values** source address (ipv4/ipv6)

**detail** — Debugs detailed information on the PIM assert mechanism.

## Debug Commands

### bsr

|                    |                                                                                                                      |
|--------------------|----------------------------------------------------------------------------------------------------------------------|
| <b>Syntax</b>      | <b>bsr [detail]</b><br><b>no bsr</b>                                                                                 |
| <b>Context</b>     | debug>router>pim                                                                                                     |
| <b>Description</b> | This command enables debugging for PIM Bootstrap mechanism.<br>The <b>no</b> form of the command disables debugging. |
| <b>Parameters</b>  | <b>detail</b> — Debugs detailed information on the PIM assert mechanism.                                             |

### data

|                    |                                                                                                                                                                                                                                                                                                                                                                                |
|--------------------|--------------------------------------------------------------------------------------------------------------------------------------------------------------------------------------------------------------------------------------------------------------------------------------------------------------------------------------------------------------------------------|
| <b>Syntax</b>      | <b>data [group <i>grp-ip-address</i>] [source <i>ip-address</i>] [detail]</b><br><b>no data</b>                                                                                                                                                                                                                                                                                |
| <b>Context</b>     | debug>router>pim                                                                                                                                                                                                                                                                                                                                                               |
| <b>Description</b> | This command enables/disables debugging for PIM data exception.                                                                                                                                                                                                                                                                                                                |
| <b>Parameters</b>  | <b>group <i>grp-ip-address</i></b> — Debugs information associated with the specified data exception.<br><b>Values</b> multicast group address (ipv4/ipv6)<br><b>source <i>ip-address</i></b> — Debugs information associated with the specified data exception.<br><b>Values</b> source address (ipv4/ipv6)<br><b>detail</b> — Debugs detailed IP data exception information. |

### db

|                    |                                                                                                                                                                                                                                                                                                                                                                      |
|--------------------|----------------------------------------------------------------------------------------------------------------------------------------------------------------------------------------------------------------------------------------------------------------------------------------------------------------------------------------------------------------------|
| <b>Syntax</b>      | <b>db [group <i>grp-ip-address</i>] [source <i>ip-address</i>] [detail]</b><br><b>no db</b>                                                                                                                                                                                                                                                                          |
| <b>Context</b>     | debug>router>pim                                                                                                                                                                                                                                                                                                                                                     |
| <b>Description</b> | This command enables/disables debugging for PIM database.                                                                                                                                                                                                                                                                                                            |
| <b>Parameters</b>  | <b>group <i>grp-ip-address</i></b> — Debugs information associated with the specified database.<br><b>Values</b> multicast group address (ipv4/ipv6) or zero<br><b>source <i>ip-address</i></b> — Debugs information associated with the specified database.<br><b>Values</b> source address (ipv4/ipv6)<br><b>detail</b> — Debugs detailed IP database information. |

## interface

**Syntax** **interface** [*ip-int-name* | *mt-int-name* | *ip-address*] [**detail**]  
**no interface**

**Context** debug>router>pim

**Description** This command enables/disables debugging for PIM interface.

**Parameters** *ip-int-name* — Debugs the information associated with the specified IP interface name.

**Values** IPv4 or IPv6 interface address

*mt-int-address* — Debugs the information associated with the specified VPRN ID and group address.

*ip-address* — Debugs the information associated with the specified IP address.

**detail** — Debugs detailed IP interface information.

## jp

**Syntax** **jp** [**group** *grp-ip-address*] [**source** *ip-address*] [**detail**]  
**no jp**

**Context** debug>router>pim

**Description** This command enables/disables debugging for PIM Join-Prune mechanism.

**Parameters** **group** *grp-ip-address* — Debugs information associated with the specified Join-Prune mechanism.

**Values** multicast group address (ipv4/ipv6) or zero

**source** *ip-address* — Debugs information associated with the specified Join-Prune mechanism.

**Values** source address (ipv4/ipv6)

**detail** — Debugs detailed Join-Prune mechanism information.

## mrib

**Syntax** **mrib** [**group** *grp-ip-address*] [**source** *ip-address*] [**detail**]  
**no mrib**

**Context** debug>router>pim

**Description** This command enables/disables debugging for PIM MRIB.

**Parameters** **group** *grp-ip-address* — Debugs information associated with the specified PIM MRIB.

**Values** multicast group address (ipv4/ipv6)

**source** *ip-address* — Debugs information associated with the specified PIM MRIB.

**Values** source address (ipv4/ipv6)

## Debug Commands

**detail** — Debugs detailed MRIB information.

### msg

**Syntax** **msg [detail]**  
**no msg**

**Context** debug>router>pim

**Description** This command enables/disables debugging for PIM messaging.

**Parameters** **detail** — Debugs detailed messaging information.

### packet

**Syntax** **packet [hello | register | register-stop | jp | bsr | assert | crp] [ip-int-name | ip-address]**  
**no packet**

**Context** debug>router>pim

**Description** This command enables/disables debugging for PIM packets.

**Parameters** **hello | register | register-stop | jp | bsr | assert | crp** — PIM packet types.

*ip-int-name* — Debugs the information associated with the specified IP interface name.

**Values** IPv4 or IPv6 interface address

*ip-address* — Debugs the information associated with the specified IP address of a particular packet type.

### register

**Syntax** **register [group grp-ip-address] [source ip-address] [detail]**  
**no register**

**Context** debug>router>pim

**Description** This command enables/disables debugging for PIM Register mechanism.

**Parameters** **group** *grp-ip-address* — Debugs information associated with the specified PIM register.

**Values** multicast group address (ipv4/ipv6)

**source** *ip-address* — Debugs information associated with the specified PIM register.

**Values** source address (ipv4/ipv6)

**detail** — Debugs detailed register information.

## rtm

|                    |                                                      |
|--------------------|------------------------------------------------------|
| <b>Syntax</b>      | <b>rtm [detail]</b><br><b>no rtm</b>                 |
| <b>Context</b>     | debug>router>pim                                     |
| <b>Description</b> | This command enables/disables debugging for PIM RTM. |
| <b>Parameters</b>  | <b>detail</b> — Debugs detailed RTM information.     |

## s-pmsi

|                    |                                                                                                                                                                                                                                                               |
|--------------------|---------------------------------------------------------------------------------------------------------------------------------------------------------------------------------------------------------------------------------------------------------------|
| <b>Syntax</b>      | <b>s-pmsi</b> [{ <i>vpnSrcAddr</i> [ <i>vpnGrpAddr</i> ]} [ <i>mdSrcAddr</i> ]] [ <b>detail</b> ]<br><b>no s-pmsi</b>                                                                                                                                         |
| <b>Context</b>     | debug>router>pim                                                                                                                                                                                                                                              |
| <b>Description</b> | This command enables debugging for PIM selective provider multicast service interface.<br>The <b>no</b> form of the command disables the debugging.                                                                                                           |
| <b>Parameters</b>  | <i>vpnSrcAddr</i> — Specifies the VPN source address.<br><i>vpnGrpAddr</i> — Specifies the VPN group address<br><i>mdSrcAddr</i> — Specifies the source address of the multicast sender.<br><b>detail</b> — Displays detailed information for selective PMSI. |

## msdp

|                    |                                                                                                                                              |
|--------------------|----------------------------------------------------------------------------------------------------------------------------------------------|
| <b>Syntax</b>      | [ <b>no</b> ] <b>msdp</b>                                                                                                                    |
| <b>Context</b>     | debug>router                                                                                                                                 |
| <b>Description</b> | This command enables debugging for Multicast Source Discovery Protocol (MSDP).<br>The <b>no</b> form of the command disables MSDP debugging. |

## packet

|                    |                                                                                                                                                             |
|--------------------|-------------------------------------------------------------------------------------------------------------------------------------------------------------|
| <b>Syntax</b>      | <b>packet</b> [ <i>pkt-type</i> ] [ <b>peer</b> <i>ip-address</i> ]                                                                                         |
| <b>Context</b>     | debug>router>msdp                                                                                                                                           |
| <b>Description</b> | This command enables debugging for Multicast Source Discovery Protocol (MSDP) packets.<br>The <b>no</b> form of the command disables MSDP packet debugging. |

## Debug Commands

**Parameters** *pkt-type* — Debugs information associated with the specified packet type.  
**Values** keep-alive, source-active, sa-request, sa-response  
**peer ip-address** — Debugs information associated with the specified peer IP address.

### pim

**Syntax** **pim** [*grp-address*]  
**no pim**

**Context** debug>router>msdp

**Description** This command enables debugging for Multicast Source Discovery Protocol (MSDP) PIM. The **no** form of the command disables MSDP PIM debugging.

**Parameters** *grp-address* — Debugs the IP multicast group address for which this entry contains information.

### rtm

**Syntax** **rtm** [*rp-address*]  
**no rtm**

**Context** debug>router>msdp

**Description** This command enables debugging for Multicast Source Discovery Protocol (MSDP) route table manager (RTM). The **no** form of the command disables MSDP RTM debugging.

**Parameters** *rp-address* — Debugs the IP multicast address for which this entry contains information.

### sa-db

**Syntax** **sa-db** [**group** *grpAddr*] [**source** *srcAddr*] [**rp** *rpAddr*]  
**no sadb**

**Context** debug>router>msdp

**Description** This command enables debugging for Multicast Source Discovery Protocol (MSDP) source-active requests. The **no** form of the command disables the MSDP source-active database debugging.

**Parameters** **group** *grpAddr* — Debugs the IP address of the group.  
**source** *srcAddr* — Debugs the source IP address.  
**rp** *rpAddr* — Debugs the specified rendezvous point RP address.



---

## In This Chapter

This chapter provides information about configuring Routing Information Protocol (RIP) parameters.

Topics in this chapter include:

- [RIP Overview on page 234](#)
  - [RIP Features on page 235](#)
    - [RIP Version Types on page 235](#)
    - [RIPv2 Authentication on page 235](#)
    - [Metrics on page 236](#)
    - [Timers on page 236](#)
    - [Import and Export Policies on page 236](#)
    - [RIP Packet Format on page 237](#)
- [RIP Configuration Process Overview on page 240](#)
- [Configuration Notes on page 241](#)

## RIP Overview

The Routing Information Protocol (RIP) is an interior gateway protocol (IGP) that uses a distance-vector algorithm to determine the best route to a destination, using hop count as the metric. In order for the protocol to provide complete information on routing, every router in the domain must participate in the protocol.

RIP is a routing protocol based on a distance vector (Bellman-Ford) algorithm, which advertises network reachability by advertising prefix/mask and the metric (also known as hop count or cost). RIP selects the route with the lowest metric as the best route. RIP differs from link-state database protocols, such as OSPF and IS-IS, in that RIP advertises reachability information directly and link-state-database-based protocols advertise topology information. Each node is responsible for calculating the reachability information from the topology.

7750 SR OS software supports RIPv1 and RIPv2. RIPv1, specified in RFC 1058, was written and implemented prior to the introduction of CIDR. It assumes the netmask information for non-local routes, based on the class the route belongs to:

- Class A – 8 bit mask
- Class B – 16 bit mask
- Class C – 24 bit mask

RIPv2 was written after CIDR was developed and transmits netmask information with every route. Because of the support for CIDR routes and other enhancements in RIPv2 such as triggered updates, multicast advertisements, and authentication, most production networks use RIPv2. However, there are some older systems (hosts and routers) that only support RIPv1, especially when RIP is used simply to advertise default routing information.

RIP is supported on all IP interfaces, including both network and access interfaces.

## RIP Features

RIP, a UDP-based protocol, updates its neighbors, and the neighbors update their neighbors, and so on. Each host that uses RIP has a routing process that sends and receives datagrams on UDP port number 520.

Each RIP router advertises all RIP routes periodically via RIP updates. Each update can contain a maximum of 25 route advertisements. This limit is imposed by RIP specifications. RIP can sometimes be configured to send as many as 255 routes per update. The formats of the RIPv1 and RIPv2 updates are slightly different and are shown below. Additionally, RIPv1 updates are sent to a broadcast address, RIPv2 updates can be either sent to a broadcast or multicast address (224.0.0.9). RIPv2 supports subnet masks, a feature that was not available in RIPv1.

A network address of 0.0.0.0 is considered a default route. A default route is used when it is not convenient to list every possible network in the RIP updates, and when one or more closely-connected gateways in the system are prepared to handle traffic to the networks that are not listed explicitly. These gateways create RIP entries for the address 0.0.0.0, as if it were a network to which they are connected.

---

## RIP Version Types

7750 SR OS allows you to specify the RIP version that will be sent to RIP neighbors and RIP updates that will be accepted and processed. 7750 SR OS allows the following combinations:

- Send *only* RIPv1 or send *only* RIPv2 to either the broadcast or multicast address or send no messages.

The default sends RIPv2 formatted messages to the broadcast address.

- Receive *only* RIPv1, receive *only* RIPv2, or receive *both* RIPv1 and RIPv2, or receive none.

The default receives both.

---

## RIPv2 Authentication

RIPv2 messages carry more information, which permit the use of a simple authentication mechanism to secure table updates. The 7750 SR OS implementation enables the use of a simple password (plain text) or message digest (MD5) authentication.

### Metrics

By default, RIP advertises all RIP routes to each peer every 30 seconds. RIP uses a hop count metric to determine the distance between the packet's source and destination. The metric/cost values for a valid route is 1 through 15. A metric value of 16 (infinity) indicates that the route is no longer valid and should be removed from the router's routing table.

Each router along the path increments the hop count value by 1. When a router receives a routing update with new or different destination information, the metric increments by 1.

The maximum number of hops in a path is 15. If a router receives a routing update with a metric of 15 and contains a new or modified entry, increasing the metric value by 1 will cause the metric increment to 16 (infinity). Then, the destination is considered unreachable.

The 7750 SR OS implementation of RIP uses *split horizon with poison reverse* to protect from such problems as "counting to infinity". Split horizon with poison reverse means that routes learned from a neighbor through a given interface are advertised in updates out of the same interface but with a metric of 16 (infinity).

---

### Timers

RIP uses numerous timers to determine how often RIP updates are sent and how long routes are maintained.

- Update — Times the interval between periodic routing updates.
  - Timeout — This timer is initialized when a route is established and any time an update message is received for the route. When this timer expires, the route is no longer valid. It is retained in the table for a short time, so that neighbors can be notified that the route has been dropped.
  - Flush — When the flush timer expires, the route is removed from the tables.
- 

### Import and Export Policies

Routing policies can control the content of the routing tables, the routes that are advertised and the best route to take to reach a destination. Import route policies determine which routes are accepted from RIP neighbors. Export route policies determine which routes are exported from the route table to RIP. By default, RIP does not export routes it has learned to its neighbors.

There are no default routing policies. A policy must be created explicitly and applied to a RIP import or export command.

## RIP Packet Format

The RIP packet format is displayed in [Figure 3](#):

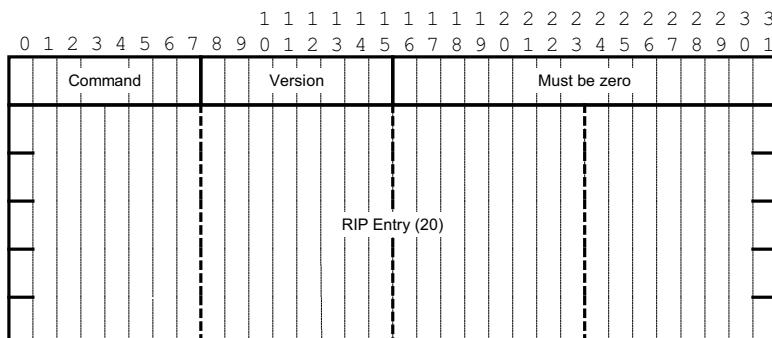

**Figure 3: RIP Packet Format**

A RIP packet consists of the following fields:

- **Command** — Indicates whether the packet is a request or a response message. The request asks the responding system to send all or part of its routing table. The response may be sent in response to a request, or it may be an unsolicited routing update generated by the sender.
- **Version** — The RIP version used. This field can signal different potentially incompatible versions.
- **Must be zero** — Not used in RIPv1. This field provides backward compatibility with pre-standard varieties of RIP. The default value is zero.
- **Address family identifier (AFI)** — The AFI is the type of address. RIP can carry routing information for several different protocols. Each entry in this field has an AFI to indicate the type of address being specified. The IP AFI is 2.
- **Address** — The IP address for the packet.
- **Metric** — Specifies the number of hops to the destination.
- **Mask** — Specifies the IP address mask.
- **Next hop** — Specifies the IP address of the next router along the path to the destination.

### RIPv1 Format

There can be between 1 and 25 (inclusive) RIP entries. [Figure 4](#) displays RIPv1 format:

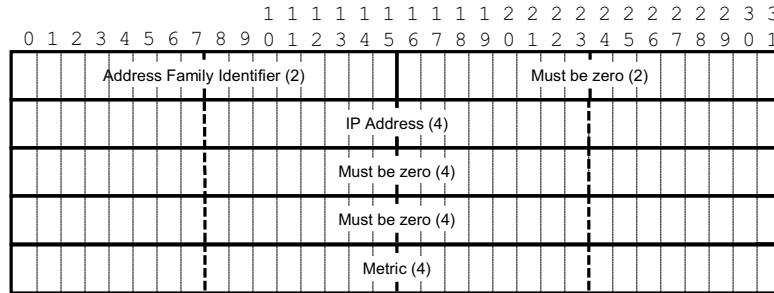

**Figure 4: RIPv1 Format**

### RIPv2 Format

The RIP packet format is displayed in [Figure 5](#):

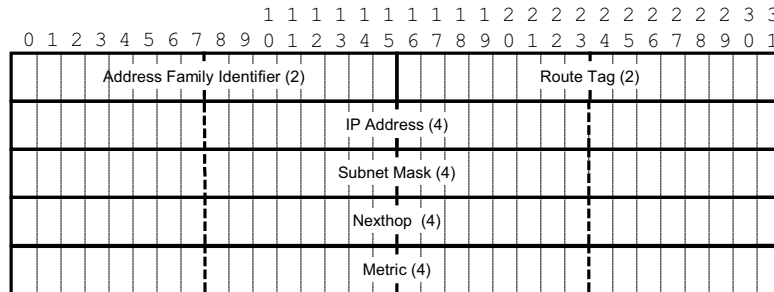

**Figure 5: RIPv2 Format**

The RIPv2 packets include the following fields:

- Subnet mask — The subnet mask for the entry. If this field is zero, no subnet mask has been specified for the entry.
- Next hop —The IP address of the next hop to forward packets.

## Hierarchical Levels

The minimum RIP configuration must define one group and one neighbor. The parameters configured on the global level are inherited by the group and neighbor levels. Parameters can be modified and overridden on a level-specific basis. RIP command hierarchy consists of three levels:

- Global
- Group
- Neighbor

Many of the hierarchical RIP commands can be modified on different levels. The most specific value is used. That is, a RIP group-specific command takes precedence over a global RIP command. A neighbor-specific statement takes precedence over a global RIP and group-specific command; for example, if you modify a RIP neighbor-level command default, the new value takes precedence over group- and global-level settings.

## RIP Configuration Process Overview

Figure 6 displays the process to configure RIP parameters.

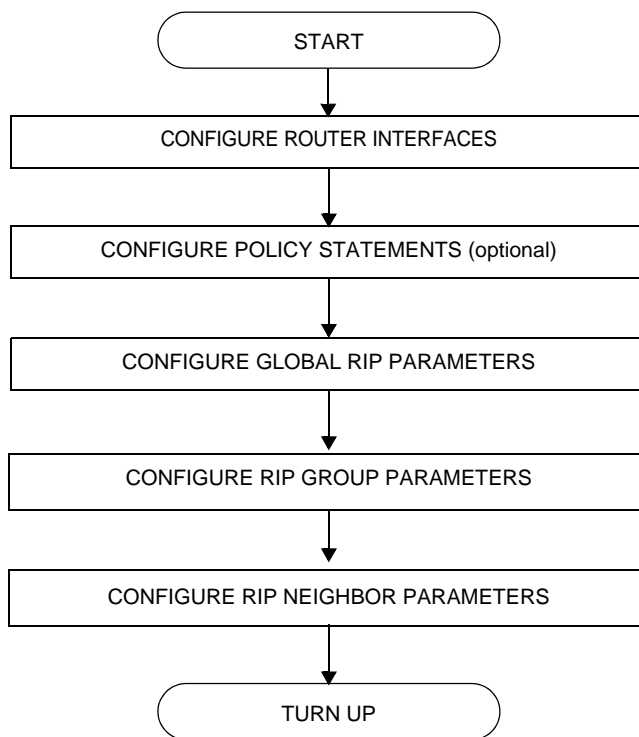

**Figure 6: RIP Configuration and Implementation Flow**



## Configuration Notes

This section describes RIP configuration caveats.

---

### General

- Before RIP neighbor parameters can be configured, router interfaces must be configured.
- RIP must be explicitly created for each router interface. There are no default RIP instances on a 7750 SR-Series router.



## Configuring RIP with CLI

This section provides information to configure Routing Information Protocol (RIP) using the command line interface.

Topics in this section include:

- [RIP Configuration Overview on page 244](#)
- [Basic RIP Configuration on page 245](#)
- [Common Configuration Tasks on page 246](#)
  - [Configuring Interfaces on page 247](#)
  - [Configuring a Route Policy on page 248](#)
  - [Configuring RIP Parameters on page 250](#)
  - [Configuring Global-Level Parameters on page 252](#)
  - [Configuring Group-Level Parameters on page 253](#)
  - [Configuring Neighbor-Level Parameters on page 254](#)
- [RIP Configuration Management Tasks on page 255](#)
  - [Modifying RIP Parameters on page 255](#)
  - [Deleting a Group on page 256](#)
  - [Deleting a Neighbor on page 256](#)

## RIP Configuration Overview

---

### Preconfiguration Requirements

Configure the following entities before beginning the RIP configuration:

- (Optional) Policy statements should be defined in the `config>router>policy-options` context.
- 

### RIP Hierarchy

RIP is configured in the `config>router>rip` context. RIP is not enabled by default. Three hierarchical levels are included in RIP configurations:

- Global
- Group
- Neighbor

Commands and parameters configured on the global level are inherited by the group and neighbor levels although parameters configured on the group and neighbor levels take precedence over global configurations.

## Basic RIP Configuration

This section provides information to configure RIP and examples of common configuration tasks. For a router to accept RIP updates, in the `config>router>rip` context, you must define at least one group and one neighbor. A 7750 SR-Series router will ignore updates received from routers on interfaces not configured for RIP. Configuring other RIP commands and parameters are optional.

By default, the local router imports all routes from this neighbor and does not advertise routes. The router receives both RIPv1 and RIPv2 update messages with 25 to 255 route entries per message.

The RIP configuration commands have three primary configuration levels: `rip` for global configurations, `group group-name` for RIP group configurations, and `neighbor ip-int-name` for RIP neighbor configurations. Within the different levels, the configuration commands are identical. For the repeated commands, the command that is most specific to the neighboring router is in effect; that is, neighbor settings have precedence over group settings which have precedence over RIP global settings.

The minimal RIP parameters that need to be configured in the `config>router>rip` context are:

- Group
- Neighbor

The following example displays a basic RIP configuration.

```
ALA-A>config>router>rip# info

 group "RIP-ALA-A"
 neighbor "to-ALA-4"
 exit
 exit

ALA-A>config>router>rip#
```

## Common Configuration Tasks

This section provides a brief overview of the tasks that must be performed to configure RIP and provides the CLI commands.

Configure RIP hierarchically using the global level (applies to all peers), the group level (applies to all peers in peer-group), or the neighbor level (only applies to the specified interface). By default, group members inherit the group's configuration parameters although a parameter can be modified on a per-member basis without affecting the group-level parameters.

Many of the hierarchical RIP commands can be used on different levels. The most specific value is used. That is, a RIP group-specific command takes precedence over a global RIP command. A neighbor-specific statement takes precedence over a global RIP or group-specific command.

All RIP instances must be explicitly created on each device. Once created, RIP is administratively enabled.

To configure RIP, perform the following tasks:

1. Configure interfaces
2. Configure policy statements (optional)
3. Enable RIP
4. Configure group parameters
5. Configure neighbor parameters

## Configuring Interfaces

The following command sequences create a logical IP interface. The logical interface can associate attributes like an IP address, port, Link Aggregation Group (LAG), or the system. For more information about configuring interfaces, refer to the *IP Router Configuration Overview* chapter.

To configure a network interface:

**CLI Syntax:**

```
config> router
 interface ip-int-name
 address ip-addr{/mask-length|mask} [broadcast {all-
 ones|host-ones}]
 port port-id
```

The following example displays router interface configuration command usage:

**Example:**

```
config>router> interface "to-ALA-4"
config>router>if$ address 10.10.12.1/24
config>router>if# port 1/1/1
config>router>if# exit
```

The following example displays the IP configuration output showing the interface information.

```
ALA-3>config>router# info
#-----
echo "IP Configuration "
#-----
 interface "system"
 address 10.10.10.103/32
 exit
 interface "to-ALA-4"
 address 10.10.12.1/24
 port 1/1/1
 exit
#-----
ALA-3>config>router#
```

## Configuring a Route Policy

The `import route policy` command allows you to filter routes being imported by the local router from its neighbors. If no match is found, the local router does not import any routes.

The `export route policy` command allows you to determine which routes are exported from the route table to RIP. By default, RIP does not export routes it has learned to its neighbors. If no export policy is specified, non-RIP routes will not be exported from the routing table manager to RIP.

If multiple policy names are specified, the policies are evaluated in the order they are specified. The first policy that matches is applied. If multiple export commands are issued, the last command entered will override the previous command. A maximum of five policy names can be specified.

This section only provides brief instructions to configure route policies. For more details, refer to the *Route Policy Overview* chapter.

To enter the mode to create or edit route policies, you must enter the `begin` keyword at the `config>router>policy-options` prompt. Other editing commands include:

- The `commit` command saves and enables changes made to route policies during a session.
- The `abort` command discards changes that have been made to route policies during a session.

Use the following CLI syntax to configure a policy to use for the RIP `global`, `group`, and `neighbor import` and `export` commands.

**CLI Syntax:**

```
config>router>policy-options
 begin
 commit
 abort
 policy-statement name
 description text
 default-action {accept|reject}
 entry entry-id
 description text
 action {accept|reject}
 from
 to
```



Use the following CLI syntax to enter the edit mode:

**CLI Syntax:** config>router> policy-options  
begin

The following example displays some commands to configure a policy statement. Policy option commands are configured in the config>router context. Use the commit command to save the changes.

**Example:** config>router>policy-options# begin  
policy-options# policy-statement "RIP-policy"  
policy-options>policy-statement\$ description "this is a  
test RIP policy"  
policy-options>policy-statement>default# entry 1  
policy-options>policy-statement>entry\$ action accept  
policy-options>policy-statement>entry# exit  
policy-options>policy-statement# default-action reject  
policy-options>policy-statement# exit  
policy-options# commit

ALA-A>config>router>policy-options# info

```

policy-statement "RIP-policy"
description "this is a test RIP policy"
entry 1
action accept
exit
exit
default-action reject
exit

```

ALA-A>config>router>policy-options>policy-statement#

## Configuring RIP Parameters

Use the CLI syntax displayed below for:

- [Configuring RIP Parameters on page 250](#)
- [Configuring Group-Level Parameters on page 253](#)
- [Configuring Neighbor-Level Parameters on page 254](#)

```
CLI Syntax: config>router
 rip
 authentication-key [authentication-key|hash-key
 [hash|hash2]
 authentication-type {none|password|message-digest|mes-
 sage-digest-20}
 check-zero {enable|disable}
 description string
 export policy-name [policy-name ...up to 5 max]
 import policy-name [policy-name ...up to 5 max]
 message-size number
 metric-in metric
 metric-out metric
 preference number
 receive {both|none|version-1|version-2}
 send {broadcast|multicast|none|version-1|both}
 no shutdown
 split-horizon {enable|disable}
 timers update timeout flush

 group group-name
 authentication-key [authentication-key|hash-key
 [hash|hash2]
 authentication-type {none|password|message-digest|
 message-digest-20}
 check-zero {enable|disable}
 description string
 export policy-name [policy-name ...up to 5 max]]
 import policy-name [policy-name ...up to 5 max]]
 message-size number
 metric-in metric
 metric-out metric
 preference number
 receive {both|none|version-1|version-2}
 send {broadcast|multicast|none|version-1}
 no shutdown
 split-horizon {enable|disable}
 timers update timeout flush
```

```
neighbor ip-int-name
 authentication-key [authentication-key|hash-key
 [hash|hash2]
 authentication-type {none|password|message-digest|
 message-digest-20}
 check-zero {enable|disable}
 description string
 export policy-name [policy-name ...up to 5 max]]
 import policy-name [policy-name ...up to 5 max]]
 message-size number
 metric-in metric
 metric-out metric
 preference number
 receive {both|none|version-1|version-2}
 send {broadcast|multicast|none|version-1}
 split-horizon {enable|disable}
 timers update timeout flush
 no shutdown
```

## Configuring Global-Level Parameters

Once the RIP protocol instance is created, the `no shutdown` command is not required since RIP is administratively enabled upon creation. Minimally, to enable RIP on a router, at least one group and one neighbor must be configured. There are no default groups or neighbors. Each group and neighbor must be explicitly configured.

NOTE: Careful planning is essential to implement commands that can affect the behavior of global, group, and neighbor-levels. Because the RIP commands are hierarchical, analyze the values that can disable features on a particular level. Use the following CLI syntax to configure global-level RIP parameters:

```
CLI Syntax: config>router
 rip
 authentication-key [authentication-key|hash-key
 [hash|hash2]
 authentication-type {password|message-digest}
 check-zero {enable|disable}
 export policy-name [policy-name ...up to 5 max]
 import policy-name [policy-name ...up to 5 max]
 message-size number
 metric-in metric
 metric-out metric
 preference number
 receive {both|none|version-1|version-2}
 send {broadcast|multicast|none|version-1|both}
 no shutdown
 split-horizon {enable|disable}
 timers update timeout flush
```

The following example displays global RIP configuration command usage:

```
Example: config>router# rip
config>router>rip# authentication-type password
config>router>rip# authentication-key test123
config>router>rip# receive both
config>router>rip# split-horizon enable
config>router>rip# timers 300 600 600
config>router>rip>group# exit
```

The following example displays the RIP group configuration:

```
ALA-A>config>router>rip# info

authentication-type simple
authentication-key "ac18651vz1d" hash
timers 300 600 600

ALA-A>config>router>rip#
```

## Configuring Group-Level Parameters

A group is a collection of related RIP peers. The group name should be a descriptive name for the group. Follow your group, name, and ID naming conventions for consistency and to help when troubleshooting faults.

All parameters configured for a group are applied to the group and are inherited by each peer (neighbor), but a group parameter can be overridden on a specific neighbor-level basis. Use the following CLI syntax to configure a group:

```
CLI Syntax: config>router# rip
 group group-name
 authentication-key [authentication-key|hash-key]
 [hash|hash2]
 authentication-type {password|message-digest}
 check-zero {enable|disable}
 description string
 export policy-name [policy-name ...]
 import policy-name [policy-name ...]
 message-size number
 metric-in metric
 metric-out metric
 preference number
 receive {both|none|version-1|version-2}
 send {broadcast|multicast|none|version-1|both}
 no shutdown
 split-horizon {enable|disable}
 timers update timeout flush
```

The following example displays group configuration command usage:

```
Example: config>router# rip
 config>router>rip# group headquarters
 config>router>rip>group$ description "Mt. View"
 config>router>rip>group# no shutdown
```

The following example displays the RIP group configuration:

```
ALA-A>config>router>rip# info

authentication-type simple
authentication-key "ac18651vzld" hash
timers 300 600 600
group "headquarters"
 description "Mt. View"
exit

ALA-A>config>router>rip#
```

## Configuring Neighbor-Level Parameters

After you create a group name and assign options, add neighbor interfaces within the same group. All parameters configured for the peer group level are applied to each neighbor, but a group parameter can be overridden on a specific neighbor basis.

Use the following CLI syntax to add a neighbor to a group and define options that override the same group-level command value:

```
CLI Syntax: config>router# rip
 group group-name
 neighbor ip-int-name
 authentication-key [authentication-key|hash-key]
 [hash|hash2]
 authentication-type {password|message-digest}
 check-zero {enable|disable}
 description string
 export policy-name [policy-name ...]
 import policy-name [policy-name ...]
 message-size number
 metric-in metric
 metric-out metric
 preference number
 receive {both|none|version-1|version-2}
 send {broadcast|multicast|none|version-1}
 split-horizon {enable|disable}
 timers update timeout flush
 no shutdown
```

The following example displays neighbor configuration command usage:

```
Example: config>router# rip
config>router>rip# group headquarters1
config>router>rip>group# neighbor ferguson-274
config>router>rip>group>neighbor$ preference 255
config>router>rip>group>neighbor# send both
config>router>rip>group>neighbor# split-horizon enable
config>router>rip>group>neighbor# message-size 255
```

The following example displays the neighbor configured in group “headquarters”.

```
ALA-A>config>router>rip>group>neighbor# info

 message-size 255
 preference 255
 split-horizon enable
 no timers

ALA-A>config>router>rip>group>neighbor#
```

## RIP Configuration Management Tasks

Examples are provided for the following RIP configuration management tasks:

- [Modifying RIP Parameters on page 255](#)
- [Deleting a Group on page 256](#)
- [Deleting a Neighbor on page 256](#)

### Modifying RIP Parameters

Modify, add or remove RIP parameters in the CLI. The changes are applied immediately. For the complete list of CLI commands, refer to [Configuring RIP Parameters on page 250](#).

**CLI Syntax:**

```
config>router# rip
 group group-name
 . . .
 neighbor ip-int-name
 . . .
```

**Example:**

```
config>router>rip# group "headquarters"
config>router>rip>group# neighbor "ferguson-274"
config>router>rip>group>neighbor# import RIPpolicy
config>router>rip>group>neighbor# message-size 150
```

The following example displays the updated parameters:

```
ALA-A>config>router>rip# info

authentication-type simple
authentication-key "ac1865lvzld" hash
timers 300 600 600
group "headquarters"
 description "Mt. View"
 neighbor "ferguson-274"
 import "RIPpolicy"
 message-size 150
 preference 255
 split-horizon enable
 no timers
 exit
exit

ALA-A>config>router>rip#
```

### Deleting a Group

A group must be shut down first in order to delete it.

Use the following CLI syntax to shut down and then delete a group:

**CLI Syntax:** config>router# rip  
                  [no] group *group-name*  
                  shutdown

**Example:** config>router# rip  
              config>router>rip# group "RIP-ALA-3"  
              config>router>rip>group# shutdown  
              config>router>rip>group# exit  
              config>router>rip# no group "RIP-ALA-33"

If you try to delete the group without shutting it down first, the following message appears:

```
INFO: RIP #1204 group should be administratively down - virtual router
index 1,group RIP-ALA-4
```

---

### Deleting a Neighbor

The neighbor must be shut down before it can be deleted.

Use the following CLI syntax to delete a neighbor:

**CLI Syntax:** config>router# rip  
                  [no] group *group-name*  
                  [no] neighbor *ip-int-name*  
                  shutdown

**Example:** config>router# rip  
              config>router>rip# group "RIP-ALA-4"  
              config>router>rip>group# neighbor "to-ALA-3"  
              config>router>rip>group>neighbor# shutdown  
              config>router>rip>group>neighbor# exit  
              config>router>rip>group# no neighbor "to-ALA-3"

If you try to delete the neighbor before it is shut down, the following message appears:

```
INFO: RIP #1101 neighbor should be administratively down - virtual router
index
```



---

## RIP Command Reference

---

### Command Hierarchies

- [Configuration Commands on page 257](#)
  - [Group Commands on page 258](#)
  - [Neighbor Commands on page 259](#)
- [Show RIP Commands on page 260](#)
- [Clear RIP Commands on page 260](#)
- [Debug RIP Commands on page 260](#)

### Configuration Commands

```

config
 — router router-name
 — [no] rip
 — authentication-key [authentication-key | hash-key] [hash | hash2]
 — no authentication-key
 — authentication-type {none | password | message-digest | message-digest-20}
 — no authentication-type
 — check-zero {enable | disable}
 — no check-zero
 — description string
 — no description
 — export policy-name [policy-name ... (up to 5 max)]
 — no export
 — export-limit number [log percentage]
 — no export-limit
 — import policy-name [policy-name ... (up to 5 max)]
 — no import
 — message-size max-num-of-routes
 — no message-size
 — metric-in metric
 — no metric-in
 — metric-out metric
 — no metric-out
 — preference preference
 — no preference
 — receive receive-type
 — no receive
 — send send-type
 — no send
 — [no] shutdown
 — split-horizon {enable | disable}
 — no split-horizon
 — timers update timeout flush
 — no timers

```

## Group Commands

- config**
- **router** *router-name*
- **[no] rip**
- **[no] group** *group-name*
  - **authentication-key** [*authentication-key* | *hash-key*] [**hash** | **hash2**]
  - **no authentication-key**
  - **authentication-type** {**none** | **password** | **message-digest** | **message-digest-20**}
  - **no authentication-type**
  - **check-zero** {**enable** | **disable**}
  - **no check-zero**
  - **description** *description-string*
  - **no description**
  - **export** *policy-name* [*policy-name* ... (up to 5 max)]
  - **no export**
  - **import** *policy-name* [*policy-name* ... (up to 5 max)]
  - **no import**
  - **message-size** *max-num-of-routes*
  - **no message-size**
  - **metric-in** *metric*
  - **no metric-in**
  - **metric-out** *metric*
  - **no metric-out**
  - **preference** *preference*
  - **no preference**
  - **receive** *receive-type*
  - **no receive**
  - **send** *send-type*
  - **no send**
  - **[no] shutdown**
  - **split-horizon** {**enable** | **disable**}
  - **no split-horizon**
  - **timers** *update timeout flush*
  - **no timers**

## Neighbor Commands

```

config
 — router router-name
 — [no] rip
 — [no] group group-name
 — [no] neighbor ip-int-name
 — authentication-key [authentication-key | hash-key] [hash | hash2]
 — no authentication-key
 — authentication-type {none | password | message-digest}
 — no authentication-type
 — check-zero {enable | disable}
 — no check-zero
 — description description-string
 — no description
 — export policy-name [policy-name ... (up to 5 max)]
 — no export
 — import policy-name [policy-name ... (up to 5 max)]
 — no import
 — message-size max-num-of-routes
 — no message-size
 — metric-in metric
 — no metric-in
 — metric-out metric
 — no metric-out
 — preference preference
 — no preference
 — receive receive-type
 — no receive
 — send send-type
 — no send
 — [no] shutdown
 — split-horizon {enable | disable}
 — no split-horizon
 — timers update timeout flush
 — no timers

```

## Show RIP Commands

```
show
 — router
 — rip
 — database [ip-prefix [/mask] [longer] [peer ip-address] [detail]]
 — group [name] [detail]
 — neighbors [ip-int-name | ip-addr] [detail] [advertised-routes]
 — peer [interface-name]
 — statistics [ip-int-name | ip-addr]
```

## Clear RIP Commands

```
clear
 — router
 — rip
 — database
 — statistics [neighbor ip-int-name | ip-addrres]
```

## Debug RIP Commands

```
debug
 — router
 — rip
 — [no] auth [neighbor ip-int-name | ip-addrres]
 — [no] error [neighbor ip-int-name | ip-addrres]
 — [no] events [neighbor ip-int-name | ip-addrres]
 — [no] holddown [neighbor ip-int-name | ip-addrres]
 — [no] packets [neighbor ip-int-name | ip-addrres]
 — [no] request [neighbor ip-int-name | ip-addrres]
 — [no] trigger [neighbor ip-int-name | ip-addrres]
 — [no] updates [neighbor ip-int-name | ip-addrres]
```

---

# RIP Configuration Commands

---

## Generic Commands

### description

**Syntax** **description** *string*  
**no description**

**Context** config>router>rip>group *group-name*  
config>router>rip>group *group-name*>neighbor *ip-int-name*

**Description** This command creates a text description stored in the configuration file for a configuration context. The **description** command associates a text string with a configuration context to help identify the context in the configuration file.

The **no** form of the command removes any description string from the context.

**Default** **no description** — no description associated with the configuration context.

**Parameters** *string* — The description character string. Allowed values are any string up to 80 characters long composed of printable, 7-bit ASCII characters. If the string contains special characters (#, \$, spaces, etc.), the entire string must be enclosed within double quotes.

### shutdown

**Syntax** [**no**] **shutdown**

**Context** config>router>rip  
config>router>rip>group *group-name*  
config>router>rip>group *group-name*>neighbor *ip-int-name*

**Description** This command administratively disables an entity. Downing an entity does not change, reset or remove any configuration settings or statistics. Many objects must be shutdown before they may be deleted.

The **shutdown** command administratively downs an entity. Administratively downing an entity changes the operational state of the entity to down and the operational state of any entities contained within the administratively down entity.

Unlike other commands and parameters where the default state will not be indicated in the configuration file, **shutdown** and **no shutdown** are always indicated in system generated configuration files.

The **no** form of the command puts an entity into the administratively enabled state.

**Special Cases** **RIP Global** — In the config>router>rip context, the **shutdown** command administratively enables/disables the RIP protocol instance. If RIP is globally shutdown, then all RIP group and neighbor interfaces transition to the operationally down state. Routes learned from a neighbor that is shutdown are immediately removed

## RIP Configuration Commands

from the RIP database and route table manager (RTM). A RIP protocol instance is administratively enabled by default.

**RIP Group** — In the `config>router>rip>group group-name` context, the **shutdown** command administratively enables/disables the RIP group. If a RIP group is shutdown, all member neighbor interfaces transition to the operationally down state. Routes learned from a neighbor that is shutdown are immediately removed from the RIP database and route table manager (RTM). A RIP group is administratively enabled by default.

**RIP Neighbor** — In the `config>router>rip>group group-name>neighbor ip-int-name` context, the **shutdown** command administratively enables/disables the RIP neighbor interface. If a RIP neighbor is shutdown, the neighbor interface transitions to the operationally down state. Routes learned from a neighbor that is shutdown are immediately removed from the RIP database and route table manager (RTM). A RIP neighbor interface is administratively enabled by default.

### rip

**Syntax** `[no] rip`

**Context** `config>router`

**Description** This command creates the context to configure the RIP protocol instance.

When a RIP instance is created, the protocol is enabled by default. To start or suspend execution of the RIP protocol without affecting the configuration, use the **[no] shutdown** command.

The **no** form of the command deletes the RIP protocol instance removing all associated configuration parameters.

**Default** `no rip` — No RIP protocol instance defined.

### authentication-key

**Syntax** `authentication-key [authentication-key | hash-key] [hash | hash2]  
no authentication-key`

**Context** `config>router>rip  
config>router>rip>group group-name  
config>router>rip>group group-name>neighbor ip-int-name`

**Description** This command sets the authentication password to be passed between RIP neighbors.

The authentication type and authentication key must match exactly for the RIP message to be considered authentic and processed.

The **no** form of the command removes the authentication password from the configuration and disables authentication.

**Default** `no authentication-key` — No authentication key configured.

- Parameters**
- authentication-key* — The authentication key. Allowed values are any string up to 16 characters long composed of printable, 7-bit ASCII characters. If the string contains special characters (#, \$, spaces, etc.), the entire string must be enclosed within double quotes.
  - hash-key* — The hash key. The key can be any combination of ASCII characters up to 33 characters in length (encrypted). If spaces are used in the string, enclose the entire string in quotation marks (“ ”).
- This is useful when a user must configure the parameter, but, for security purposes, the actual unencrypted key value is not provided.
- hash** — Specifies the key is entered in an encrypted form. If the **hash** parameter is not used, the key is assumed to be in a non-encrypted, clear text form. For security, all keys are stored in encrypted form in the configuration file with the **hash** parameter specified.
  - hash2** — Specifies the key is entered in a more complex encrypted form. If the **hash2** parameter is not used, the less encrypted **hash** form is assumed.

## authentication-type

- Syntax** **authentication-type {none|password|message-digest|message-digest-20}**  
**no authentication-type**
- Context** config>router>rip  
config>router>rip>group *group-name*  
config>router>rip>group *group-name*>neighbor *ip-int-name*
- Description** This command sets the type of authentication to be used between RIP neighbors.  
The type and password must match exactly for the RIP message to be considered authentic and processed.  
The **no** form of the command removes the authentication type from the configuration and effectively disables authentication.
- Default** **no authentication-type** — No authentication enabled.
- Parameters**
  - none** — The **none** parameter explicitly disables authentication at a given level (global, group, neighbor). If the command does not exist in the configuration, the parameter is inherited.
  - password** — Specify password to enable simple password (plain text) authentication. If authentication is enabled and no authentication type is specified in the command, simple **password** authentication is enabled.
  - message-digest** — Configures 16 byte message digest for MD5 authentication. If this option is configured, then at least one **message-digest-key must** be configured.
  - message-digest-20** — Configures 20 byte message digest for MD5 authentication in accordance with RFC 2082, *RIP-2 MD5 Authentication*. If this option is configured, then at least one **message-digest-key** must be configured.

## RIP Configuration Commands

### check-zero

|                      |                                                                                                                                                                                                                                                                                                                                                                                                                                                                                                                                                                                                                                                                                                                                                                                                                                                                                                                                                                                                           |
|----------------------|-----------------------------------------------------------------------------------------------------------------------------------------------------------------------------------------------------------------------------------------------------------------------------------------------------------------------------------------------------------------------------------------------------------------------------------------------------------------------------------------------------------------------------------------------------------------------------------------------------------------------------------------------------------------------------------------------------------------------------------------------------------------------------------------------------------------------------------------------------------------------------------------------------------------------------------------------------------------------------------------------------------|
| <b>Syntax</b>        | <b>check-zero</b> { <b>enable</b>   <b>disable</b> }<br><b>no check-zero</b>                                                                                                                                                                                                                                                                                                                                                                                                                                                                                                                                                                                                                                                                                                                                                                                                                                                                                                                              |
| <b>Context</b>       | config>router>rip<br>config>router>rip>group <i>group-name</i><br>config>router>rip>group <i>group-name</i> >neighbor <i>ip-int-name</i>                                                                                                                                                                                                                                                                                                                                                                                                                                                                                                                                                                                                                                                                                                                                                                                                                                                                  |
| <b>Description</b>   | <p>This command enables checking for zero values in fields specified to be zero by the RIPv1 and RIPv2 specifications.</p> <p>The <b>check-zero enable</b> command enables checking of the mandatory zero fields in the RIPv1 and RIPv2 specifications and rejecting non-compliant RIP messages.</p> <p>The <b>check-zero disable</b> command disables this check and allows the receipt of RIP messages even if the mandatory zero fields are non-zero.</p> <p>This configuration parameter can be set at three levels: global level (applies to all groups and neighbor interfaces), group level (applies to all neighbor interfaces in the group) or neighbor level (only applies to the specified neighbor interface). The most specific value is used. In particular if no value is set (<b>no check-zero</b>), the setting from the less specific level is inherited by the lower level.</p> <p>The <b>no</b> form of the command removes the <b>check-zero</b> command from the configuration.</p> |
| <b>Special Cases</b> | <b>RIP Global</b> — By default, check-zero is disabled at the global RIP instance level.                                                                                                                                                                                                                                                                                                                                                                                                                                                                                                                                                                                                                                                                                                                                                                                                                                                                                                                  |
| <b>Parameters</b>    | <b>enable</b> — Specifies reject RIP messages which do not have zero in the RIPv1 and RIPv2 mandatory fields.<br><b>disable</b> — Specifies allows receipt of RIP messages which do not have the mandatory zero fields reset.                                                                                                                                                                                                                                                                                                                                                                                                                                                                                                                                                                                                                                                                                                                                                                             |

### export

|                    |                                                                                                                                                                                                                                                                                                                                                                                                                                                                                                                                                                                                                                                                                        |
|--------------------|----------------------------------------------------------------------------------------------------------------------------------------------------------------------------------------------------------------------------------------------------------------------------------------------------------------------------------------------------------------------------------------------------------------------------------------------------------------------------------------------------------------------------------------------------------------------------------------------------------------------------------------------------------------------------------------|
| <b>Syntax</b>      | <b>export</b> <i>policy-name</i> [ <i>policy-name</i> ...up to 5 max]<br><b>no export</b>                                                                                                                                                                                                                                                                                                                                                                                                                                                                                                                                                                                              |
| <b>Context</b>     | config>router>rip<br>config>router>rip>group <i>group-name</i><br>config>router>rip>group <i>group-name</i> >neighbor <i>ip-int-name</i>                                                                                                                                                                                                                                                                                                                                                                                                                                                                                                                                               |
| <b>Description</b> | <p>This command specifies the export route policies used to determine which routes are exported to RIP.</p> <p>If no export policy is specified, non-RIP routes will not be exported from the routing table manager to RIP. RIP-learned routes will be exported to RIP neighbors.</p> <p>If multiple policy names are specified, the policies are evaluated in the order they are specified. The first policy that matches is applied. If multiple export commands are issued, the last command entered will override the previous command. A maximum of five policy names can be specified.</p> <p>The <b>no</b> form of the command removes all policies from the configuration.</p> |
| <b>Default</b>     | <b>no export</b> — No export route policies specified.                                                                                                                                                                                                                                                                                                                                                                                                                                                                                                                                                                                                                                 |



**Parameters** *policy-name* — The export route policy name. Allowed values are any string up to 32 characters long composed of printable, 7-bit ASCII characters. If the string contains special characters (#, \$, spaces, etc.), the entire string must be enclosed within double quotes.

The specified name(s) must already be defined.

## export-limit

**Syntax** **export-limit** *number* [**log** *percentage*]  
**no export-limit**

**Context** config>router>rip

**Description** This command configures the maximum number of routes (prefixes) that can be exported into RIP from the route table.

The **no** form of the command removes the parameters from the configuration.

**Default** no export-limit, the export limit for routes or prefixes is disabled..

**Parameters** *number* — Specifies the maximum number of routes (prefixes) that can be exported into RIP from the route table.

**Values** 1 — 4294967295

**log percentage** — Specifies the percentage of the export-limit, at which a warning log message and SNMP notification would be sent.

**Values** 1 — 100

## group

**Syntax** [**no**] **group** *group-name*

**Context** config>router>rip

**Description** This command creates a context for configuring a RIP group of neighbor interfaces.

RIP groups are a way of logically associating RIP neighbor interfaces to facilitate a common configuration for RIP interfaces.

The **no** form of the command deletes the RIP neighbor interface group. Deleting the group will also remove the RIP configuration of all the neighbor interfaces currently assigned to this group.

**Default** **no group** — No group of RIP neighbor interfaces defined.

**Parameters** *group-name* — The RIP group name. Allowed values are any string up to 32 characters long composed of printable, 7-bit ASCII characters. If the string contains special characters (#, \$, spaces, etc.), the entire string must be enclosed within double quotes.

## RIP Configuration Commands

### import

|                    |                                                                                                                                                                                                                                                                                                                                                                                                                                                                                                                                                                                                                                                                                                                             |
|--------------------|-----------------------------------------------------------------------------------------------------------------------------------------------------------------------------------------------------------------------------------------------------------------------------------------------------------------------------------------------------------------------------------------------------------------------------------------------------------------------------------------------------------------------------------------------------------------------------------------------------------------------------------------------------------------------------------------------------------------------------|
| <b>Syntax</b>      | <b>import</b> <i>policy-name</i> [ <i>policy-name</i> ...up to 5 max]<br><b>no import</b>                                                                                                                                                                                                                                                                                                                                                                                                                                                                                                                                                                                                                                   |
| <b>Context</b>     | config>router>rip<br>config>router>rip>group <i>group-name</i><br>config>router>rip>group <i>group-name</i> >neighbor <i>ip-int-name</i>                                                                                                                                                                                                                                                                                                                                                                                                                                                                                                                                                                                    |
| <b>Description</b> | <p>This command configures import route policies to determine which routes are accepted from RIP neighbors. If no import policy is specified, RIP accepts all routes from configured RIP neighbors. Import policies can be used to limit or modify the routes accepted and their corresponding parameters and metrics.</p> <p>If multiple policy names are specified, the policies are evaluated in the order they are specified. The first policy that matches is applied. If multiple import commands are issued, the last command entered will override the previous command. A maximum of five policy names can be specified.</p> <p>The <b>no</b> form of the command removes all policies from the configuration.</p> |
| <b>Default</b>     | <b>no import</b> — No import route policies specified.                                                                                                                                                                                                                                                                                                                                                                                                                                                                                                                                                                                                                                                                      |
| <b>Parameters</b>  | <p><i>policy-name</i> — The import route policy name. Allowed values are any string up to 32 characters long composed of printable, 7-bit ASCII characters. If the string contains special characters (#, \$, spaces, etc.), the entire string must be enclosed within double quotes.</p> <p>The specified name(s) must already be defined.</p>                                                                                                                                                                                                                                                                                                                                                                             |

### message-size

|                    |                                                                                                                                                             |
|--------------------|-------------------------------------------------------------------------------------------------------------------------------------------------------------|
| <b>Syntax</b>      | <b>message-size</b> <i>max-num-of-routes</i><br><b>no message-size</b>                                                                                      |
| <b>Context</b>     | config>router>rip<br>config>router>rip>group <i>group-name</i><br>config>router>rip>group <i>group-name</i> >neighbor <i>ip-int-name</i>                    |
| <b>Description</b> | <p>This command configures the maximum number of routes per RIP update message.</p> <p>The <b>no</b> form of the command reverts to the default value.</p>  |
| <b>Default</b>     | <b>message-size 25</b> — A maximum of 25 routes per RIP update message.                                                                                     |
| <b>Parameters</b>  | <p><i>max-num-of-routes</i> — The maximum number of RIP routes per RIP update message expressed as a decimal integer.</p> <p><b>Values</b>     25 — 255</p> |

## metric-in

**Syntax** **metric-in** *metric*  
**no metric-in**

**Context** config>router>rip  
 config>router>rip>group *group-name*  
 config>router>rip>group *group-name*>neighbor *ip-int-name*

**Description** This command configures the metric added to routes received from a RIP neighbor.  
 When applying an export policy to a RIP configuration, the policy overrides the metric values determined through calculations involving the **metric-in** and **metric-out** values.  
 The **no** form of the command reverts to the default value.

**Default** **metric-in 1** — Add 1 to the metric of routes received from a RIP neighbor.

**Parameters** *metric* — The value added to the metric of routes received from a RIP neighbor expressed as a decimal integer.

**Values** 1 — 16

## metric-out

**Syntax** **metric-out** *metric*  
**no metric-out**

**Context** config>router>rip  
 config>router>rip>group *group-name*  
 config>router>rip>group *group-name*>neighbor *ip-int-name*

**Description** This command configures the metric assigned to routes exported into RIP and advertised to RIP neighbors.  
 When applying an export policy to a RIP configuration, the policy overrides the metric values determined through calculations involving the **metric-in** and **metric-out** values.  
 The **no** form of the command reverts to the default value.

**Default** **metric-out 1** — Routes exported from non-RIP sources are given a metric of 1.

**Parameters** *metric* — The value added to the metric for routes exported into RIP and advertised to RIP neighbors expressed as a decimal integer.

**Values** 1 — 16

## RIP Configuration Commands

### neighbor

**Syntax** `[no] neighbor ip-int-name`

**Context** `config>router>rip>group group-name`

**Description** This command creates a context for configuring a RIP neighbor interface.

By default, interfaces are not activated in any interior gateway protocol, such as RIP, unless explicitly configured.

The **no** form of the command deletes the RIP interface configuration for this interface. The **shutdown** command in the `config>router>rip>group group-name>neighbor ip-int-name` context can be used to disable an interface without removing the configuration for the interface.

**Default** **no neighbor** — No RIP interfaces defined.

**Parameters** *ip-int-name* — The IP interface name. Interface names must be unique within the group of defined IP interfaces for **config router interface** and **config service ies interface** commands. An interface name cannot be in the form of an IP address. Interface names can be any string up to 32 characters long composed of printable, 7-bit ASCII characters. If the string contains special characters (#, \$, spaces, etc.), the entire string must be enclosed within double quotes.

If the IP interface name does not exist or does not have an IP address configured, an error message will be returned.

### preference

**Syntax** `preference preference`  
**no preference**

**Context** `config>router>rip`  
`config>router>rip>group group-name`  
`config>router>rip>group group-name>neighbor ip-int-name`

**Description** This command configures the preference for RIP routes.

A route can be learned by the router from different protocols in which case the costs are not comparable. When this occurs the preference is used to decide which route will be used.

Different protocols should not be configured with the same preference, if this occurs the tiebreaker is per the default preference table as defined in [Table 7](#). If multiple routes are learned with an identical preference using the same protocol, the lowest cost route is used.

If multiple routes are learned with an identical preference using the same protocol and the costs (metrics) are equal, then the decision of what route to use is determined by the configuration of the **ecmp** in the `config>router` context.

The **no** form of the command reverts to the default value.

**Default** **preference 100** — Preference of 100 for RIP routes.

**Parameters** *preference* — The preference for RIP routes expressed as a decimal integer. Defaults for different route types are listed in [Table 7](#).

**Table 7: Route Preference Defaults by Route Type**

| Route Type             | Preference | Configurable |
|------------------------|------------|--------------|
| Direct attached        | 0          | No           |
| Static routes          | 5          | Yes          |
| OSPF internal          | 10         | Yes          |
| IS-IS level 1 internal | 15         | Yes          |
| IS-IS level 2 internal | 18         | Yes          |
| RIP                    | 100        | Yes          |
| OSPF external          | 150        | Yes          |
| IS-IS level 1 external | 160        | Yes          |
| IS-IS level 2 external | 165        | Yes          |
| BGP                    | 170        | Yes          |
| <b>Values</b>          | 0 — 255    |              |

## receive

**Syntax** `receive {both | none | version-1 | version-2}`  
`no receive`

**Context** `config>router>rip`  
`config>router>rip>group group-name`  
`config>router>rip>group group-name>neighbor ip-int-name`

**Description** This command configures the type(s) of RIP updates that will be accepted and processed. If **both** or **version-2** is specified, the RIP instance listens for and accepts packets sent to the broadcast and multicast (224.0.0.9) addresses.

If **version-1** is specified, the router only listens for and accept packets sent to the broadcast address.

This control can be issued at the global, group or interface level. The default behavior is to accept and process both RIPv1 and RIPv2 messages.

The **no** form of the command reverts to the default value.

**Default** `receive both`

**Parameters** **both** — Specifies that RIP updates in either version 1 or version 2 format will be accepted.  
**none** — Specifies that RIP updates will not be accepted.

## RIP Configuration Commands

**version-1** — Specifies that RIP updates in version 1 format only will be accepted.

**version-2** — Specifies that RIP updates in version 2 format only will be accepted.

### send

**Syntax** **send** {**broadcast** | **multicast** | **none** | **version-1**}  
**no send**

**Context** config>router>rip  
config>router>rip>group *group-name*  
config>router>rip>group *group-name*>neighbor *ip-int-name*

**Description** This command specifies the type of RIP messages sent to RIP neighbors.  
If **version-1** is specified, the router need only listen for and accept packets sent to the broadcast address.  
This control can be issued at the global, group or interface level.  
The **no** form of the command reverts to the default value.

**Default** **send broadcast** — RIPv2 formatted messages will be sent to the broadcast address.

**Parameters** **broadcast** — Specifies send RIPv2 formatted messages to the broadcast address.  
**multicast** — Specifies send RIPv2 formatted messages to the multicast address.  
**none** — Specifies not to send any RIP messages (i.e. silent listener).  
**version-1** — Specifies send RIPv1 formatted messages to the broadcast address.

### split-horizon

**Syntax** **split-horizon** {**enable** | **disable**}  
**no split-horizon**

**Context** config>router>rip  
config>router>rip>group *group-name*  
config>router>rip>group *group-name*>neighbor *ip-int-name*

**Description** This command enables the use of split-horizon.  
RIP uses split-horizon with poison-reverse to protect from such problems as “counting to infinity”. Split-horizon with poison reverse means that routes learned from a neighbor through a given interface are advertised in updates out of the same interface but with a metric of 16 (infinity).  
The **split-horizon disable** command enables split horizon without poison reverse. This allows the routes to be re-advertised on interfaces other than the interface that learned the route, with the advertised metric equaling an increment of the metric-in value.  
This configuration parameter can be set at three levels: global level (applies to all groups and neighbor interfaces), group level (applies to all neighbor interfaces in the group) or neighbor level (only applies to the

specified neighbor interface). The most specific value is used. In particular if no value is set (**no split-horizon**), the setting from the less specific level is inherited by the lower level.

The **no** form of the command disables split horizon command which allows the lower level to inherit the setting from an upper level.

**Default** **enabled**

**Parameters** **enable** — Specifies enable split horizon and poison reverse.

**disable** — Specifies disable split horizon allowing routes to be re-advertised on the same interface on which they were learned with the advertised metric incremented by the **metric-in** value.

## timers

**Syntax** **timers** *update timeout flush*  
**no timers**

**Context** config>router>rip  
config>router>rip>group *group-name*  
config>router>rip>group *group-name*>neighbor *ip-int-name*

**Description** This command configures values for the update, timeout and flush RIP timers.

The RIP update timer determines how often RIP updates are sent.

If the route is not updated by the time the RIP timeout timer expires, the route is declared invalid but is maintained in the RIP database.

The RIP flush timer determines how long a route is maintained in the RIP database after it has been declared invalid. Once the flush timer expires, the route is removed from the RIP database.

The **no** form of the command reverts to the default values.

**Default** **timers 30 180 120** — RIP update timer set to 30 seconds, timeout timer to 180 seconds and flush timer to 120 seconds.

**Parameters** *update* — The RIP update timer value in seconds expressed as a decimal integer.

**Values** 1 — 600

*timeout* — The RIP timeout timer value in seconds expressed as a decimal integer.

**Values** 1 — 1200

*flush* — The RIP flush timer value in seconds expressed as a decimal integer.

**Values** 1 — 1200





## Show Commands

### database

**Syntax** `database [ip-prefix [/mask] [longer] [peer ip-address]`

**Context** `show>router>rip`

**Description** This command displays the routes in the RIP database.

**Output** **RIP Database Output** — The following table describes the RIP route database output fields.

| Label       | Description                                                                                                                                   |
|-------------|-----------------------------------------------------------------------------------------------------------------------------------------------|
| Destination | The RIP destination for the route.                                                                                                            |
| Peer        | The router ID of the peer router.                                                                                                             |
| NextHop     | The IP address of the next hop.                                                                                                               |
| Metric      | The hop count to rate the value of different hops.                                                                                            |
| Tag         | The value to distinguish between internal routes (learned by RIP) and external routes (learned from other protocols).                         |
| TTL         | Displays how many seconds the specific route will remain in the routing table. When an entry reaches 0, it is removed from the routing table. |
| Valid       | No — The route is not valid.<br>Yes — The route is valid.                                                                                     |

### Sample Output

```
A:ALA-A# show rip database
=====
RIP Route Database
=====
Destination Peer NextHop Metric Tag TTL Valid

180.0.0.10/32 180.1.7.15 0.0.0.0 2 0x0000 163 No
180.0.0.10/32 180.1.8.14 0.0.0.0 2 0x0000 179 No
180.0.0.14/32 180.1.8.14 0.0.0.0 1 0x0000 179 Yes
180.0.6.0/24 180.1.7.15 0.0.0.0 11 0x2002 163 No
180.0.6.0/24 180.1.8.14 0.0.0.0 11 0x2002 179 No
180.0.7.0/24 180.1.7.15 0.0.0.0 11 0x2002 163 No
180.1.5.0/24 180.1.7.15 0.0.0.0 2 0x0000 151 Yes
180.1.5.0/24 180.1.8.14 0.0.0.0 1 0x0000 167 No
180.100.17.16/30 180.1.7.15 0.0.0.0 2 0x0000 151 No
180.100.17.16/30 180.1.8.14 0.0.0.0 2 0x0000 167 No
=====
```

## Show Commands

```
No. of Routes: 10
=====
A:ALA-A#
```

### group

**Syntax** `group [group-name] [detail]`

**Context** `show>router>rip`

**Description** Display RIP group information.

**Parameters** *group-name* — Displays RIP group information for the specified group.  
**detail** — Displays detailed RIP group information.

**Output** **Standard RIP Group Output** — The following table describes the standard command output fields for a RIP group.

| Label     | Description                                                                                                                                                                                                                                                                                                                              |
|-----------|------------------------------------------------------------------------------------------------------------------------------------------------------------------------------------------------------------------------------------------------------------------------------------------------------------------------------------------|
| Group     | The RIP group name.                                                                                                                                                                                                                                                                                                                      |
| Adm       | Down — The RIP group is administratively down.<br>Up — The RIP group is administratively up.                                                                                                                                                                                                                                             |
| Opr       | Down — The RIP group is operationally down.<br>Up — The RIP group is operationally up.                                                                                                                                                                                                                                                   |
| Send Mode | Bcast — Specifies that RIPv2 formatted messages are sent to the broadcast address.<br>Mcast — Specifies that RIPv2 formatted messages are sent to the multicast address.<br>None — Specifies that no RIP messages are sent (i.e., silent listener)<br>RIPv1 — Specifies that RIPv1 formatted messages are sent to the broadcast address. |
| Recv Mode | Both — Specifies that RIP updates in either version 1 or version 2 format will be accepted.<br>None — Specifies that RIP updates will not be accepted.<br>RIPv1 — Specifies that RIP updates in version 1 format only will be accepted.<br>RIPv2 — Specifies that RIP updates in version 2 format only will be accepted.                 |
| Metric In | The metric value added to routes received from a RIP neighbor.                                                                                                                                                                                                                                                                           |

**Sample Standard RIP Group Output**

```
A:ALA-A# show router rip group
=====
RIP Groups
=====
Group Adm Opr Send Recv Metric
 Mode Mode Mode Mode In

rip-group Up Down BCast Both 1
=====
A:ALA-A#
```

**Sample Detailed Output**

```
A:ALA-A# show router rip group detail
=====
RIP groups (Detail)
=====

Group "rip-group"

Description : No Description Available
Admin State : Up
Send Mode : Broadcast
Metric In : 1
Split Horizon : Enabled
Message Size : 25
Auth. Type : None
Timeout Timer : 180
Export Policies:
 None
Import Policies:
 None
Oper State : Down
Receive Mode : Both
Metric Out : 1
Check Zero : Disabled
Preference : 100
Update Timer : 30
Flush Timer : 120
=====
A:ALA-A#
```

**neighbors**

**Syntax** **neighbors** [*ip-addr* | *ip-int-name*] [**advertised-routes** | **detail**]

**Context** show>router>rip

**Description** Displays RIP neighbor interface information.

**Parameters** *ip-addr* | *ip-int-name* — Displays information for the specified IP interface.

**Default** **all neighbor interfaces**

**advertised-routes** — Displays the routes advertised to RIP neighbors. If no neighbors are specified, then all routes advertised to all neighbors are displayed. If a specific neighbor is given then only routes advertised to the given neighbor/interface are displayed.

**Default** **display RIP information**

## Show Commands

**Output** **Standard RIP Neighbor Output** — The following table describes the standard command output fields for a RIP group.

**Table 8: RIP Neighbor Standard Output Fields**

| Label      | Description                                                                                                                                                                                                                                                                                                                               |
|------------|-------------------------------------------------------------------------------------------------------------------------------------------------------------------------------------------------------------------------------------------------------------------------------------------------------------------------------------------|
| Neighbor   | The RIP neighbor interface name.                                                                                                                                                                                                                                                                                                          |
| Adm        | Down — The RIP neighbor interface is administratively down.<br>Up — The RIP neighbor interface is administratively up.                                                                                                                                                                                                                    |
| Opr        | Down — The RIP neighbor interface is operationally down.<br>Up — The RIP neighbor interface is operationally up.                                                                                                                                                                                                                          |
| Primary IP | The Primary IP address of the RIP neighbor interface.                                                                                                                                                                                                                                                                                     |
| Send Mode  | Bcast — Specifies that RIPv2 formatted messages are sent to the broadcast address.<br>Mcast — Specifies that RIPv2 formatted messages are sent to the multicast address.<br>None — Specifies that no RIP messages are sent (i.e., silent listener).<br>RIPv1 — Specifies that RIPv1 formatted messages are sent to the broadcast address. |
| Recv Mode  | Both — Specifies that RIP updates in either version 1 or version 2 format will be accepted.<br>None — Specifies that RIP updates will not be accepted.<br>RIPv1 — Specifies that RIP updates in version 1 format only are accepted.<br>RIPv2 — Specifies that RIP updates in version 2 format only are accepted.                          |
| Metric In  | The metric added to routes received from a RIP neighbor.                                                                                                                                                                                                                                                                                  |

### Sample Output

```
A:ALA-A# show router rip neighbor
=====
RIP Neighbors
=====
Interface Adm Opr Primary IP Send Recv Metric
 Mode Mode Mode Mode In

router-2/1 Up Up 10.0.3.12 None Both 1
router-2/2 Up Up 10.0.5.12 BCast Both 1
router-2/3 Up Up 10.0.6.12 BCast Both 1
router-2/5 Up Up 10.0.9.12 BCast Both 1
router-2/6 Up Up 10.0.17.12 None Both 1
router-2/7 Up Up 10.0.16.12 None Both 1
```

```
=====
A:ALA-A#
```

**Output** **Detailed RIP Neighbor Output** — The following table describes the standard command output fields for a RIP group.

| Label         | Description                                                                                                                                                                                                                                                                                                                                                                                   |
|---------------|-----------------------------------------------------------------------------------------------------------------------------------------------------------------------------------------------------------------------------------------------------------------------------------------------------------------------------------------------------------------------------------------------|
| Neighbor      | The RIP neighbor name.                                                                                                                                                                                                                                                                                                                                                                        |
| Description   | The RIP neighbor description. <code>No Description Available</code> indicates no description is configured.                                                                                                                                                                                                                                                                                   |
| Primary IP    | The RIP neighbor interface primary IP address.                                                                                                                                                                                                                                                                                                                                                |
| Group         | The RIP group name of the neighbor interface.                                                                                                                                                                                                                                                                                                                                                 |
| Admin State   | <code>Down</code> — The RIP neighbor interface is administratively down.<br><code>Up</code> — The RIP neighbor interface is administratively up.                                                                                                                                                                                                                                              |
| Oper State    | <code>Down</code> — The RIP neighbor interface is operationally down.<br><code>Up</code> — The RIP neighbor interface is operationally up.                                                                                                                                                                                                                                                    |
| Send Mode     | <code>Bcast</code> — Specifies that RIPv2 formatted messages are sent to the broadcast address.<br><code>Mcast</code> — Specifies that RIPv2 formatted messages are sent to the multicast address.<br><code>None</code> — Specifies that no RIP messages are sent (i.e., silent listener).<br><code>RIPv1</code> — Specifies that RIPv1 formatted messages are sent to the broadcast address. |
| Recv Mode     | <code>Both</code> — Specifies that RIP updates in either version 1 or version 2 format will be accepted.<br><code>None</code> — Specifies that RIP updates will not be accepted.<br><code>RIPv1</code> — Specifies that RIP updates in version 1 format only will be accepted.<br><code>RIPv2</code> — Specifies that RIP updates in version 2 format only will be accepted.                  |
| Metric In     | The metric value added to routes received from a RIP neighbor.                                                                                                                                                                                                                                                                                                                                |
| Metric Out    | The value added to routes exported into RIP and advertised to RIP neighbors.                                                                                                                                                                                                                                                                                                                  |
| Split Horizon | <code>Disabled</code> — Split horizon disabled for the neighbor.<br><code>Enabled</code> — Split horizon and poison reverse enabled for the neighbor.                                                                                                                                                                                                                                         |

## Show Commands

| Label           | Description (Continued)                                                                                                                                                                                                                                                                                                                                                 |
|-----------------|-------------------------------------------------------------------------------------------------------------------------------------------------------------------------------------------------------------------------------------------------------------------------------------------------------------------------------------------------------------------------|
| Check Zero      | Disabled – Checking of the mandatory zero fields in the RIPv1 and RIPv2 specifications are not checked allowing receipt of RIP messages even if mandatory zero fields are non-zero for the neighbor.<br><br>Enabled – checking of the mandatory zero fields in the RIPv1 and RIPv2 specifications and rejecting non-compliant RIP messages is enabled for the neighbor. |
| Message Size    | The maximum number of routes per RIP update message.                                                                                                                                                                                                                                                                                                                    |
| Preference      | The preference of RIP routes from the neighbor.                                                                                                                                                                                                                                                                                                                         |
| Auth. Type      | Specifies the authentication type.                                                                                                                                                                                                                                                                                                                                      |
| Update Timer    | The current setting of the RIP update timer value expressed in seconds.                                                                                                                                                                                                                                                                                                 |
| Timeout Timer   | The current RIP timeout timer value expressed in seconds.                                                                                                                                                                                                                                                                                                               |
| Export Policies | The export route policy that is used to determine routes advertised to all peers.                                                                                                                                                                                                                                                                                       |
| Import Policies | The import route policy that is used to determine which routes are accepted from RIP neighbors.                                                                                                                                                                                                                                                                         |

### Sample Detailed Output

```
A:ALA-A# show router rip neighbor detail
=====
RIP Neighbors (Detail)
=====
Neighbor "router-2/7"

Description : No Description Available
Primary IP : 10.0.16.12 Group : seven
Admin State : Up Oper State : Up
Send Mode : None Receive Mode : Both
Metric In : 1 Metric Out : 1
Split Horizon : Enabled Check Zero : Disabled
Message Size : 25 Preference : 100
Auth. Type : None Update Timer : 3
Timeout Timer : 6 Flush Timer : 6
Export Policies:
 Rip2Rip
 direct2Rip
 bgp2Rip
Import Policies:
 None
=====
A:ALA-A#
```

**Sample Output**

```
A:ALA-A# show router rip neighbors interface advertised-routes
=====
RIP Advertised Routes
=====
Destination Interface NextHop Metric Tag TTL

180.0.0.2/32 180.1.8.12 0.0.0.0 10 0x2002 n/a
180.0.0.5/32 180.1.8.12 0.0.0.0 10 0x2002 n/a
180.0.0.8/32 180.1.8.12 0.0.0.0 10 0x2002 n/a
180.0.0.9/32 180.1.8.12 0.0.0.0 10 0x2002 n/a
180.0.0.10/32 180.1.8.12 0.0.0.0 10 0x2002 n/a
180.0.0.11/32 180.1.8.12 0.0.0.0 10 0x2002 n/a
180.0.0.12/32 180.1.8.12 0.0.0.0 1 0x0000 n/a
180.0.0.13/32 180.1.8.12 0.0.0.0 10 0x2002 n/a
180.0.0.14/32 180.1.8.12 0.0.0.0 16 0x0000 n/a
180.0.0.15/32 180.1.8.12 0.0.0.0 2 0x0000 n/a
180.0.0.16/32 180.1.8.12 0.0.0.0 3 0x0000 n/a

No. of Advertised Routes: 11
=====
A:ALA-A#
```

**peer****Syntax** `peer [ip-int-name]`**Context** `show>router>rip`**Description** Displays RIP peer information.**Parameters** *ip-int-name* — Displays peer information for peers on the specified IP interface.**Default** `display peers for all interfaces`**Output** **RIP Peer Output** — The following table describes the command output fields for a RIP peer.

| Label          | Description                               |
|----------------|-------------------------------------------|
| Peer IP Addr   | The IP address of the peer router.        |
| Interface Name | The peer interface name.                  |
| Version        | The version of RIP running on the peer.   |
| Last Update    | The number of days since the last update. |
| No. of Peers   | The number of RIP peers.                  |

**Sample Output**

```
A:ALA-A# show router rip peers
=====
```

## Show Commands

```

RIP Peers
=====
Peer IP Addr Interface Name Version Last Update

10.0.5.13 router-2/2 RIPv2 0
10.0.6.16 router-2/3 RIPv2 2
10.0.9.14 router-2/5 RIPv2 8
10.0.10.15 router-2/4 RIPv2 0

No. of Peers: 4
=====
A:ALA-A#

```

## statistics

**Syntax** `statistics [ip-addr | ip-int-name]`

**Context** `show>router>rip`

**Description** Display interface level statistics for the RIP protocol

If no IP address or interface name is specified, then all configured RIP interfaces are displayed.

If an IP address or interface name is specified, then only data regarding the specified RIP interface is displayed.

**Parameters** `ip-addr | ip-int-name` — Displays statistics for the specified IP interface.

**Output** **RIP Statistics Output** — The following table describes the output fields for RIP statistics.

| Label            | Description                                                                                                                                               |
|------------------|-----------------------------------------------------------------------------------------------------------------------------------------------------------|
| Learned Routes   | The number of RIP-learned routes were exported to RIP neighbors.                                                                                          |
| Timed Out Routes | The number of routes that have been timed out.                                                                                                            |
| Current Memory   | The amount of memory used by this RIP router instance.                                                                                                    |
| Maximum Memory   | The amount of memory allocated for this RIP router instance.                                                                                              |
| Interface        | Displays the name of each interface configured in RIP and associated RIP statistics.                                                                      |
| Primary IP       | The interface IP address.                                                                                                                                 |
| Update Timer     | The current setting of the RIP update timer value expressed in seconds.                                                                                   |
| Timeout Timer    | The current RIP timeout timer value expressed in seconds.                                                                                                 |
| Flush Timer      | The number of seconds after a route has been declared invalid that it is flushed from the route database.                                                 |
| Updates Sent     | <b>Total</b> — The total number of RIP updates that were sent.<br><br><b>Last 5 Min</b> — The number of RIP updates that were sent in the last 5 minutes. |



| Label                   | Description (Continued)                                                                                                 |
|-------------------------|-------------------------------------------------------------------------------------------------------------------------|
|                         | Last 1 Min – The number of RIP updates that were sent in the last 1 minute.                                             |
| Triggered Updates       | Total – The total number of triggered updates sent. These updates are sent before the entire RIP routing table is sent. |
|                         | Last 5 Min – The number of triggered updates that were sent in the last 5 minutes.                                      |
|                         | Last 1 Min – The number of triggered updates that were sent in the last 1 minute.                                       |
| Bad Packets Received    | Total – The total number of RIP updates received on this interface that were discarded as invalid.                      |
|                         | Last 5 Min – The number of RIP updates received on this interface that were discarded as invalid in the last 5 minutes. |
|                         | Last 1 Min – The number of RIP updates received on this interface that were discarded as invalid in the last 1 minute.  |
| RIPv1 Updates Received  | Total – The total number of RIPv1 updates received.                                                                     |
|                         | Last 5 Min – The number of RIPv1 updates received in the last 5 minutes.                                                |
|                         | Last 1 Min – The number of RIPv1 updates received in the last 1 minute.                                                 |
| RIPv1 Updates Ignored   | Total – The total number of RIPv1 updates ignored.                                                                      |
|                         | Last 5 Min – The number of RIPv1 updates ignored in the last 5 minutes.                                                 |
|                         | Last 1 Min – The number of RIPv1 updates ignored in the last 1 minute.                                                  |
| RIPv1 Bad Routes        | Total – The total number of bad routes received from the peer.                                                          |
|                         | Last 5 Min – The number of bad routes received from the peer in the last 5 minutes.                                     |
|                         | Last 1 Min – The number of bad routes received from the peer in the last minute.                                        |
| RIPv1 Requests Received | Total – The total number of times the router received RIPv1 route requests from other routers.                          |
|                         | Last 5 Min – The number of times the router received RIPv1 route requests from other routers in the last 5 minutes.     |

## Show Commands

| Label                   | Description (Continued)                                                                                             |
|-------------------------|---------------------------------------------------------------------------------------------------------------------|
|                         | Last 1 Min – The number of times the router received RIPv1 route requests from other routers in the last 1 minute.  |
| RIPv1 Requests Ignored  | Total – The total number of times the router ignored RIPv1 route requests from other routers.                       |
|                         | Last 5 Min – The number of times the router ignored RIPv1 route requests from other routers in the last 5 minutes.  |
|                         | Last 1 Min – The number of times the router ignored RIPv1 route requests from other routers in the last 1 minute.   |
| RIPv2 Updates Received  | Total – The total number of RIPv2 updates received.                                                                 |
|                         | Last 5 Min – The number of RIPv2 updates received in the last 5 minutes.                                            |
|                         | Last 1 Min – The number of RIPv2 updates received in the last minute.                                               |
| RIPv2 Updates Ignored   | Total – The total number of RIPv2 updates ignored.                                                                  |
|                         | Last 5 Min – The number of RIPv2 updates ignored in the last 5 minutes.                                             |
|                         | Last 1 Min – The number of RIPv2 updates ignored in the last minute.                                                |
| RIPv2 Bad Routes        | Total – The total number of RIPv2 bad routes received from the peer.                                                |
|                         | Last 5 Min – The number of RIPv2 bad routes received from the peer in the last 5 minutes.                           |
|                         | Last 1 Min – The number of RIPv2 bad routes received from the peer in the last minute.                              |
| RIPv2 Requests Received | Total – The total number of times the router received RIPv2 route requests from other routers.                      |
|                         | Last 5 Min – The number of times the router received RIPv2 route requests from other routers in the last 5 minutes. |
|                         | Last 1 Min – The number of times the router received RIPv2 route requests from other routers in the last minute.    |
| RIPv2 Requests Ignored  | Total – The total number of times the router ignored RIPv2 route requests from other routers.                       |
|                         | Last 5 Min – The number of times the router ignored RIPv2 route requests from other routers in the last 5 minutes.  |

| Label                 | Description (Continued)                                                                                         |
|-----------------------|-----------------------------------------------------------------------------------------------------------------|
|                       | Last 1 Min – The number of times the router ignored RIPv2 route requests from other routers in the last minute. |
| Authentication Errors | Total – The total number of authentication errors to secure table updates.                                      |
|                       | Last 5 Min – The number of authentication errors to secure table updates in the last 5 minutes.                 |
|                       | Last 1 Min – The number of authentication errors to secure table updates in the last minute.                    |

### Sample Output

```
A:ALA-A# show router rip statistics
=====
RIP Statistics
=====
Learned Routes : 0 Timed Out Routes : 0
Current Memory : 120624 Maximum Memory : 262144

Interface "to-web"

Primary IP : 10.1.1.3 Update Timer : 30
Timeout Timer : 180 Flush Timer : 120

Counter Total Last 5 Min Last 1 Min

Updates Sent 0 0 0
Triggered Updates 0 0 0
Bad Packets Received 0 0 0
RIPv1 Updates Received 0 0 0
RIPv1 Updates Ignored 0 0 0
RIPv1 Bad Routes 0 0 0
RIPv1 Requests Received 0 0 0
RIPv1 Requests Ignored 0 0 0
RIPv2 Updates Received 0 0 0
RIPv2 Updates Ignored 0 0 0
RIPv2 Bad Routes 0 0 0
RIPv2 Requests Received 0 0 0
RIPv2 Requests Ignored 0 0 0
Authentication Errors 0 0 0
=====
A:ALA-A#
```

## Clear Commands

### database

**Syntax**     **database**

**Context**     clear>router>rip

**Description**     Flush all routes in the RIP database.

### statistics

**Syntax**     **statistics** [**neighbor** *ip-int-name* | *ip-address*]

**Context**     clear>router>rip

**Description**     Clears statistics for RIP neighbors.

**Parameters**     **neighbor** *ip-int-name* | *ip-address* — Clears the statistics for the specified RIP interface.

**Default**     **clears statistics for all RIP interfaces**

---

## Debug RIP Commands

### auth

**Syntax** [no] auth [neighbor *ip-int-name* | *ip-addr*]

**Context** debug>router>rip

**Description** This command enables debugging for RIP authentication.

**Parameters** **neighbor** *ip-addr* | *ip-int-name* — Debugs the RIP authentication for the neighbor IP address or interface.

### error

**Syntax** [no] error [neighbor *ip-int-name* | *ip-addr*]

**Context** debug>router>rip

**Description** This command enables debugging for RIP errors.

**Parameters** **neighbor** *ip-addr* | *ip-int-name* — Debugs the RIP errors sent on the neighbor IP address or interface.

### events

**Syntax** [no] events [neighbor *ip-int-name* | *ip-addr*]

**Context** debug>router>rip

**Description** This command enables debugging for RIP events.

**Parameters** **neighbor** *ip-addr* | *ip-int-name* — Debugs the RIP events sent on the neighbor IP address or interface.

### holddown

**Syntax** [no] holddown [neighbor *ip-int-name* | *ip-addr*]

**Context** debug>router>rip

**Description** This command enables debugging for RIP holddowns.

**Parameters** **neighbor** *ip-addr* | *ip-int-name* — Debugs the RIP holddowns sent on the neighbor IP address or interface.

## Debug RIP Commands

### packets

**Syntax** [no] packets [neighbor *ip-int-name* | *ip-addr*]

**Context** debug>router>rip

**Description** This command enables debugging for RIP packets.

**Parameters** **neighbor** *ip-addr* | *ip-int-name* — Debugs the RIP packets sent on the neighbor IP address or interface.

### request

**Syntax** [no] request [neighbor *ip-int-name* | *ip-addr*]

**Context** debug>router>rip

**Description** This command enables debugging for RIP requests.

**Parameters** **neighbor** *ip-addr* | *ip-int-name* — Debugs the RIP requests sent on the neighbor IP address or interface.

### trigger

**Syntax** [no] trigger [neighbor *ip-int-name* | *ip-addr*]

**Context** debug>router>rip

**Description** This command enables debugging for RIP trigger updates.

**Parameters** **neighbor** *ip-addr* | *ip-int-name* — Debugs the RIP updates sent on the neighbor IP address or interface.

### updates

**Syntax** [no] updates [neighbor *ip-int-name* | *ip-addr*]

**Context** debug>router>rip

**Description** This command enables debugging for RIP updates.

**Parameters** **neighbor** *ip-addr* | *ip-int-name* — Debugs the RIP updates sent on the neighbor IP address or interface.

---

## In This Chapter

This chapter provides information about configuring the Open Shortest Path First (OSPF) protocol.

Topics in this chapter include:

- [Configuring OSPF on page 288](#)
  - [OSPF Areas on page 289](#)
    - [Backbone Area on page 289](#)
    - [Stub Area on page 290](#)
    - [Not-So-Stubby Area on page 291](#)
  - [OSPF Super Backbone on page 292](#)
  - [Authentication on page 303](#)
    - [OSPFv3 Graceful Restart Helper on page 298](#)
  - [Virtual Links on page 300](#)
  - [Neighbors and Adjacencies on page 301](#)
  - [Link-State Advertisements on page 302](#)
  - [Metrics on page 302](#)
  - [Authentication on page 303](#)
  - [IP Subnets on page 304](#)
  - [Preconfiguration Recommendations on page 304](#)
- [OSPF Configuration Process Overview on page 313](#)
- [Configuration Notes on page 314](#)

# Configuring OSPF

OSPF (Open Shortest Path First) is a hierarchical link state protocol. OSPF is an interior gateway protocol (IGP) used within large autonomous systems (ASs). OSPF routers exchange state, cost, and other relevant interface information with neighbors. The information exchange enables all participating routers to establish a network topology map. Each router applies the Dijkstra algorithm to calculate the shortest path to each destination in the network. The resulting OSPF forwarding table is submitted to the routing table manager to calculate the routing table.

When a router is started with OSPF configured, OSPF, along with the routing-protocol data structures, is initialized and waits for indications from lower-layer protocols that its interfaces are functional. Alcatel-Lucent's implementation of OSPF conforms to OSPF Version 2 specifications presented in RFC 2328, *OSPF Version 2* and OSPF Version 3 specifications presented in RFC 2740, *OSPF for IPv6*. Routers running OSPF can be enabled with minimal configuration. All default and command parameters can be modified.

Changes between OSPF for IPv4 and OSPF3 for IPv6 include the following:

- Addressing semantics have been removed from OSPF packets and the basic link-state advertisements (LSAs). New LSAs have been created to carry IPv6 addresses and prefixes.
- OSPF3 runs on a per-link basis, instead of on a per-IP-subnet basis.
- Flooding scope for LSAs has been generalized.
- Unlike OSPFv2, OSPFv3 authentication relies on IPV6's authentication header and encapsulating security payload.
- Most packets in OSPF for IPv6 are almost as compact as those in OSPF for IPv4, even with the larger IPv6 addresses.
- Most field and packet-size limitations present in OSPF for IPv4 have been relaxed.
- Option handling has been made more flexible.

Key OSPF features are:

- Backbone areas
- Stub areas
- Not-So-Stubby areas (NSSAs)
- Virtual links
- Authentication
- Route redistribution
- Routing interface parameters
- OSPF-TE extensions (Alcatel-Lucent's implementation allows MPLS fast reroute)



## OSPF Areas

The hierarchical design of OSPF allows a collection of networks to be grouped into a logical area. An area's topology is concealed from the rest of the AS which significantly reduces OSPF protocol traffic. With the proper network design and area route aggregation, the size of the route-table can be drastically reduced which results in decreased OSPF route calculation time and topological database size.

Routing in the AS takes place on two levels, depending on whether the source and destination of a packet reside in the same area (intra-area routing) or different areas (inter-area routing). In intra-area routing, the packet is routed solely on information obtained within the area; no routing information obtained from outside the area is used.

Routers that belong to more than one area are called area border routers (ABRs). An ABR maintains a separate topological database for each area it is connected to. Every router that belongs to the same area has an identical topological database for that area.

---

## Backbone Area

The OSPF backbone area, area 0.0.0.0, must be contiguous and all other areas must be connected to the backbone area. The backbone distributes routing information between areas. If it is not practical to connect an area to the backbone (see area 0.0.0.5 in [Figure 7](#)) then the ABRs (such as routers Y and Z) must be connected via a virtual link. The two ABRs form a point-to-point-like adjacency across the transit area (see area 0.0.0.4).

## Configuring OSPF

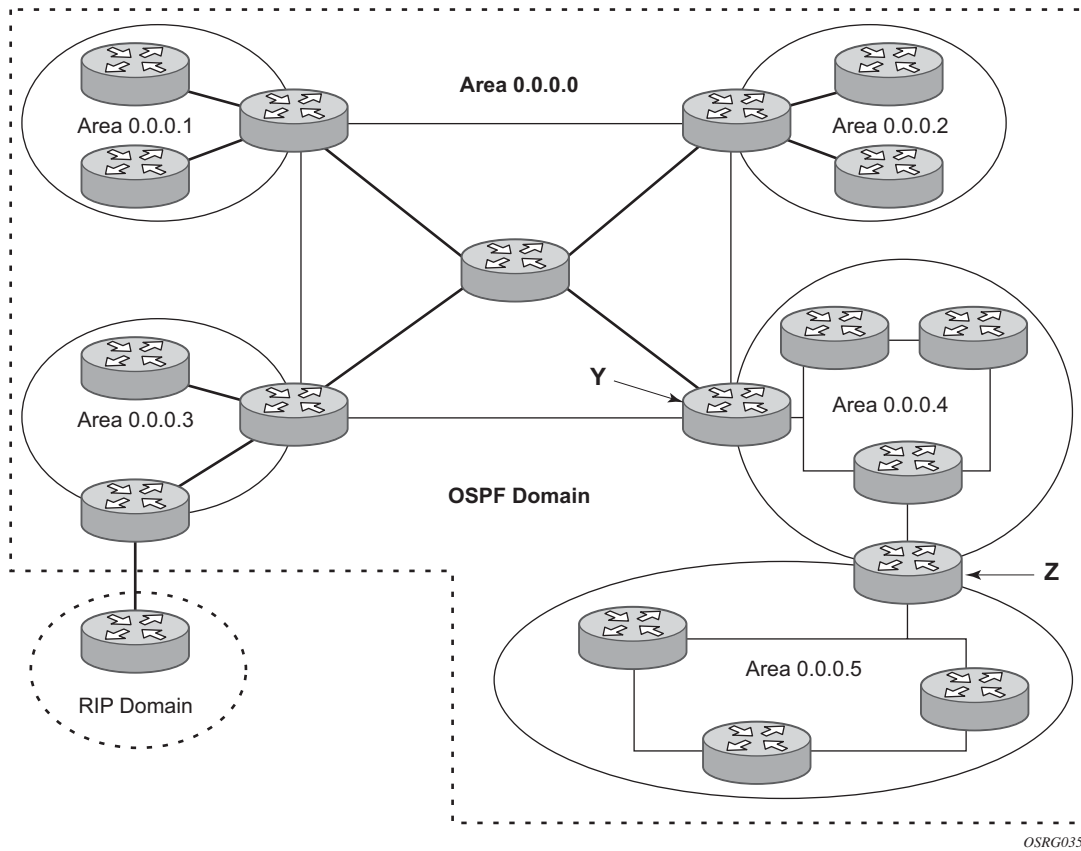

Figure 7: Backbone Area

## Stub Area

A stub area is a designated area that does not allow external route advertisements. Routers in a stub area do not maintain external routes. A single default route to an ABR replaces all external routes. This OSPF implementation supports the optional summary route (type-3) advertisement suppression from other areas into a stub area. This feature further reduces topological database sizes and OSPF protocol traffic, memory usage, and CPU route calculation time.

In Figure 7, areas 0.0.0.1, 0.0.0.2 and 0.0.0.5 could be configured as stub areas. A stub area cannot be designated as the transit area of a virtual link and a stub area cannot contain an AS boundary router. An AS boundary router exchanges routing information with routers in other ASs.

## Not-So-Stubby Area

Another OSPF area type is called a Not-So-Stubby area (NSSA). NSSAs are similar to stub areas in that no external routes are imported into the area from other OSPF areas. External routes learned by OSPF routers in the NSSA area are advertised as type-7 LSAs within the NSSA area and are translated by ABRs into type-5 external route advertisements for distribution into other areas of the OSPF domain. An NSSA area cannot be designated as the transit area of a virtual link.

In [Figure 7](#), area 0.0.0.3 could be configured as a NSSA area.

### OSPF Super Backbone

The 77x0 PE routers have implemented a version of the BGP/OSPF interaction procedures as defined in RFC 4577, *OSPF as the Provider/Customer Edge Protocol for BGP/MPLS IP Virtual Private Networks (VPNs)*. Features included in this RFC includes:

- Loop prevention
- Handling LSAs received from the CE
- Sham links
- Managing VPN-IPv4 routes received by BGP

VPRN routes can be distributed among the PE routers by BGP. If the PE uses OSPF to distribute routes to the CE router, the standard procedures governing BGP/OSPF interactions causes routes from one site to be delivered to another in type 5 LSAs, as AS-external routes.

The MPLS VPN super backbone behaves like an additional layer of hierarchy in OSPF. The PE-routers that connect the respective OSPF areas to the super backbone function as OSPF Area Border Routers (ABR) in the OSPF areas to which they are attached. In order to achieve full compatibility, they can also behave as AS Boundary Routers (ASBR) in non-stub areas.

The PE-routers insert inter-area routes from other areas into the area in which the CE-router is present. The CE-routers are not involved at any level nor are they aware of the super backbone or of other OSPF areas present beyond the MPLS VPN super backbone.

The CE always assumes the PE is an ABR:

- If the CE is in the backbone then the CE router assumes that the PE is an ABR linking one or more areas to the backbone.
- If the CE is not in the backbone then the CE believes that the backbone is on the other side of the PE.
- As such the super backbone looks like another area to the CE.

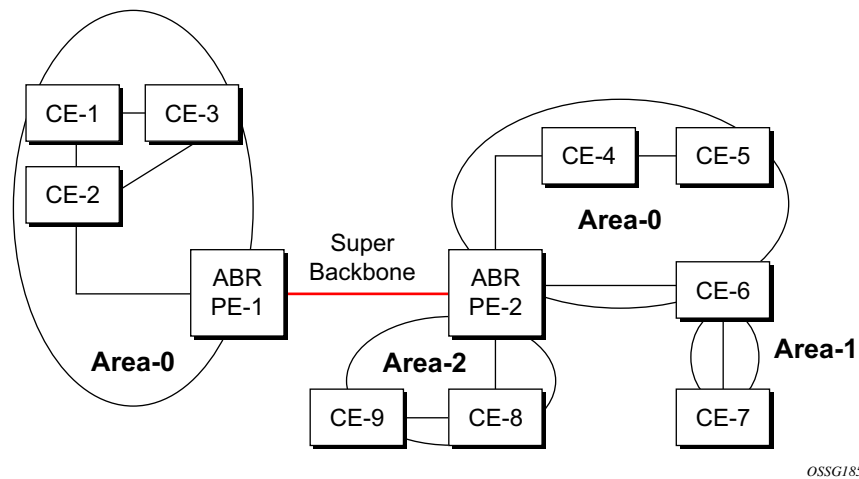

**Figure 8: PEs Connected to an MPLS-VPN Super Backbone**

In [Figure 8](#), the PEs are connected to the MPLS-VPN super backbone. In order to be able to distinguish if two OSPF instances are in fact the same and require Type 3 LSAs to be generated or are two separate routing instances where type 5 external LSAs need to be generated the concept of a domain-id is introduced.

The domain ID is carried with the MP-BGP update and indicates the source OSPF Domain. When the routes are being redistributed into the same OSPF Domain, the concepts of super backbone described above apply and Type 3 LSAs should be generated. If the OSPF domain does not match, then the route type will be external.

Configuring the super backbone (not the sham links) makes all destinations learned by PEs with matching domain IDs inter-area routes.

When configuring sham links, these links become intra-area routes if they are present in the same area.

## Sham Links

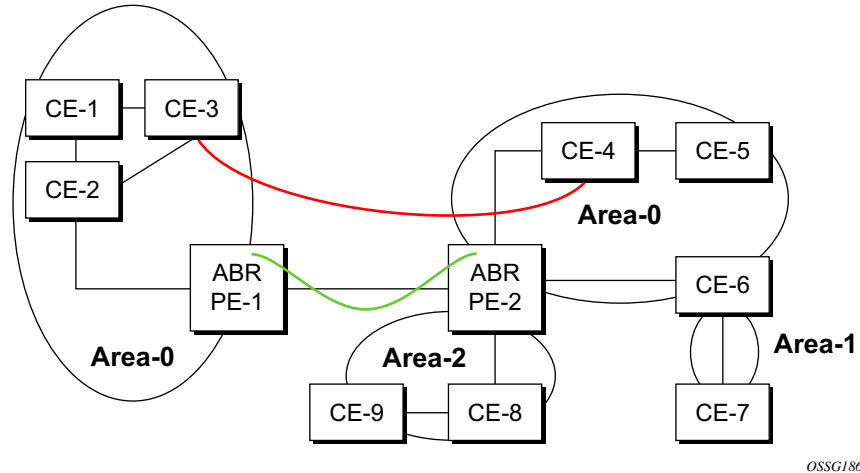

**Figure 9: Sham Links**

Figure 9 displays the red link between CE-3 and CE-4 could be a low speed OC-3/STM-1 link but because it establishes an intra-area route connection between the CE-3 and CE-4 the potentially high-speed PE-1 to PE-2 connection will not be utilized. Even with a super backbone configuration it is regarded as an inter-area connection.

The establishment of the (green) sham-link is also constructed as an intra-area link between PE routers, a normal OSPF adjacency is formed and the link-state database is exchanged across the MPLS-VPRN. As a result, the desired intra-area connectivity is created, at this time the cost of the green and red links can be managed such that the red link becomes a standby link only in case the VPN fails.

As the shamlink forms an adjacency over the MPLS-VPRN backbone network, be aware that when protocol-protection is enabled in the `config>sys>security>cpu-protection>protocol-protection` context, the operator must explicitly allow the OSPF packets to be received over the backbone network. This is performed using the `allow-sham-links` parameter of the `protocol-protection` command.

## Implementing the OSPF Super Backbone

With the OSPF super backbone architecture, the continuity of OSPF routing is preserved:

- The OSPF intra-area LSAs (type-1 and type-2) advertised by the CE are inserted into the MPLS-VPRN super backbone by redistributing the OSPF route into MP-BGP by the PE adjacent to the CE.
- The MP-BGP route is propagated to other PE-routers and inserted as an OSPF route into other OSPF areas. Considering the PEs across the super backbone always act as ABRs they will generate inter area route OSPF summary LSAs, Type 3.
- The inter-area route can now be propagated into other OSPF areas by other customer owned ABRs within the customer site.
- Customer Area 0 (backbone) routes when carried across the MPLS-VPRN using MPBGP will appear as Type 3 LSAs even if the customer area remains area 0 (backbone).

A BGP extended community (OSPF domain ID) provides the source domain of the route. This domain ID is not carried by OSPF but carried by MP-BGP as an extended community attribute.

If the configured extended community value matches the receiving OSPF domain, then the OSPF super backbone is implemented.

From a BGP perspective, the cost is copied into the MED attribute.

---

## Loop Avoidance

If a route sent from a PE router to a CE router could then be received by another PE router from one of its own CE routers then it is possible for routing loops to occur. RFC 4577 specifies several methods of loop avoidance.

---

## DN-BIT

When a Type 3 LSA is sent from a PE router to a CE router, the DN bit in the LSA options field is set. This is used to ensure that if any CE router sends this Type 3 LSA to a PE router, the PE router will not redistribute it further.

When a PE router needs to distribute to a CE router a route that comes from a site outside the latter's OSPF domain, the PE router presents itself as an ASBR (Autonomous System Border Router), and distributes the route in a type 5 LSA. The DN bit MUST be set in these LSAs to ensure that they will be ignored by any other PE routers that receive them.

DN-BIT loop avoidance is also supported.

## Configuring OSPF

### Route Tag

If a particular VRF in a PE is associated with an instance of OSPF, then by default it is configured with a special OSPF route tag value called the VPN route tag. This route tag is included in the Type 5 LSAs that the PE originates and sends to any of the attached CEs. The configuration and inclusion of the VPN Route Tag is required for backward compatibility with deployed implementations that do not set the DN bit in Type 5 LSAs.

---

### Sham Links

A sham link is only required if a backdoor link (shown as the red link in [Figure 9](#)) is present, otherwise configuring an OSPF super backbone will probably suffice.



## OSPFv3 Authentication

OSPFv3 authentication requires IPv6 IPsec and supports the following:

- IPsec transport mode
- AH and ESP
- Manual keyed IPsec Security Association (SA)
- Authentication Algorithms MD5 and SHA1

To pass OSPFv3 authentication, OSPFv3 peers must have matching inbound and outbound SAs configured using the same SA parameters (SPI, keys, etc.). The implementation must allow the use of one SA for both inbound and outbound directions.

This feature is supported on IES and VPRN interfaces as well as on virtual links.

The re-keying procedure defined in RFC 4552, *Authentication/Confidentiality for OSPFv3*, supports the following:

- For every router on the link, create an additional inbound SA for the interface being re-keyed using a new SPI and the new key.
- For every router on the link, replace the original outbound SA with one using the new SPI and key values. The SA replacement operation should be atomic with respect to sending OSPFv3 packet on the link so that no OSPFv3 packets are sent without authentication or encryption.
- For every router on the link, remove the original inbound SA.

The key rollover procedure automatically starts when the operator changes the configuration of the inbound static-sa or bi-directional static-sa under an interface or virtual link. Within the KeyRolloverInterval time period, OSPF3 accepts packets with both the previous inbound static-sa and the new inbound static-sa, and the previous outbound static-sa should continue to be used. When the timer expires, OSPF3 will only accept packets with the new inbound static-sa and for outgoing OSPF3 packets, the new outbound static-sa will be used instead.

## OSPFv3 Graceful Restart Helper

This feature extends the Graceful Restart helper function supported under other protocols to OSPFv3.

The primary difference between graceful restart helper for OSPFv2 and OSPFv3 is in OSPFv3 a different grace-LSA format is used.

As the 7750 SR, 7450 ESS or 7710 (7x50) platforms can support a fully non-stop routing model for control plane high availability the 7x50 has no need for graceful restart as defined by the IETF in various RFCs for each routing protocol. However, since the 7x50 does need to co-exist in multi-vendor networks and other routers do not always support a true non-stop routing model with stateful failover between routing control planes, there is a need to support a Graceful Restart Helper function.

Graceful restart helper mode allows the SROS based system to provide other routers which have requested it, a grace period, during which the 7750 SR, 7450 ESS or 7710 systems will continue to use routes authored by or transiting the router requesting the grace period. This is typically used when another router is rebooting the control plane but the forwarding plane is expected to continue to forward traffic based on the previously available FIB.

Figure 10 displays the Graceful OSPF restart (GRACE) LSA format. See section 2.2 of RFC 5187, *OSPFv3 Graceful Restart*.

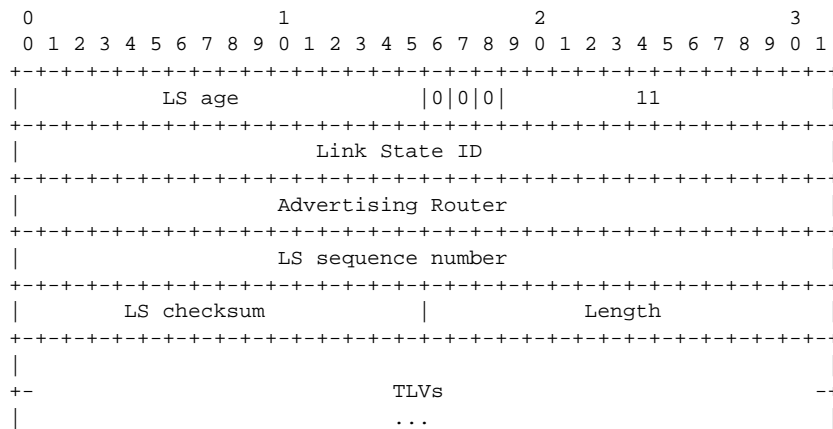
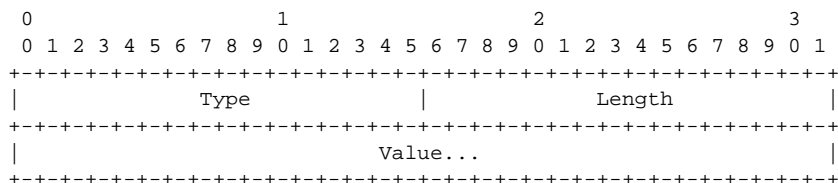

Figure 10: GRACE LSA Format

The Link State ID of a grace-LSA in OSPFv3 is the Interface ID of the interface originating the LSA.

The format of each TLV is:



TLV Format

Grace-LSA TLVs are formatted according to section 2.3.2 of RFC 3630, *Traffic Engineering (TE) Extensions to OSPF Version 2*. The Grace-LSA TLVs are used to carry the Grace period (type 1) and the reason the router initiated the graceful restart process (type 2).

Other information in RFC 5187 is directed to routers that require the full graceful restart mechanism as they do not support a stateful transition from primary or backup control plane module (CPM).

### Virtual Links

The backbone area in an OSPF AS must be contiguous and all other areas must be connected to the backbone area. Sometimes, this is not possible. You can use virtual links to connect to the backbone through a non-backbone area.

[Figure 7](#) depicts routers Y and Z as the start and end points of the virtual link while area 0.0.0.4 is the transit area. In order to configure virtual links, the router must be an ABR. Virtual links are identified by the router ID of the other endpoint, another ABR. These two endpoint routers must be attached to a common area, called the transit area. The area through which you configure the virtual link must have full routing information.

Transit areas pass traffic from an area adjacent to the backbone or to another area. The traffic does not originate in, nor is it destined for, the transit area. The transit area cannot be a stub area or a NSSA area.

Virtual links are part of the backbone, and behave as if they were unnumbered point-to-point networks between the two routers. A virtual link uses the intra-area routing of its transit area to forward packets. Virtual links are brought up and down through the building of the shortest-path trees for the transit area.

## Neighbors and Adjacencies

A router uses the OSPF Hello protocol to discover neighbors. A neighbor is a router configured with an interface to a common network. The router sends hello packets to a multicast address and receives hello packets in return.

In broadcast networks, a designated router and a backup designated router are elected. The designated router is responsible for sending link-state advertisements (LSAs) describing the network, which reduces the amount of network traffic.

The routers attempt to form adjacencies. An adjacency is a relationship formed between a router and the designated or backup designated router. For point-to-point networks, no designated or backup designated router is elected. An adjacency must be formed with the neighbor.

To significantly improve adjacency forming and network convergence, a network should be configured as point-to-point if only two routers are connected, even if the network is a broadcast media such as Ethernet.

When the link-state databases of two neighbors are synchronized, the routers are considered to be fully adjacent. When adjacencies are established, pairs of adjacent routers synchronize their topological databases. Not every neighboring router forms an adjacency. Routing protocol updates are only sent to and received from adjacencies. Routers that do not become fully adjacent remain in the two-way neighbor state.

### Link-State Advertisements

Link-state advertisements (LSAs) describe the state of a router or network, including router interfaces and adjacency states. Each LSA is flooded throughout an area. The collection of LSAs from all routers and networks form the protocol's topological database.

The distribution of topology database updates take place along adjacencies. A router sends LSAs to advertise its state according to the configured interval and when the router's state changes. These packets include information about the router's adjacencies, which allows detection of non-operational routers.

When a router discovers a routing table change or detects a change in the network, link state information is advertised to other routers to maintain identical routing tables. Router adjacencies are reflected in the contents of its link state advertisements. The relationship between adjacencies and the link states allow the protocol to detect non-operating routers. Link state advertisements flood the area. The flooding mechanism ensures that all routers in an area have the same topological database. The database consists of the collection of LSAs received from each router belonging to the area.

OSPF sends only the part that has changed and only when a change has taken place. From the topological database, each router constructs a tree of shortest paths with itself as root. OSPF distributes routing information between routers belonging to a single AS.

---

### Metrics

In OSPF, all interfaces have a cost value or routing metric used in the OSPF link-state calculation. A metric value is configured based on hop count, bandwidth, or other parameters, to compare different paths through an AS. OSPF uses cost values to determine the best path to a particular destination: the lower the cost value, the more likely the interface will be used to forward data traffic.

Costs are also associated with externally derived routing data, such as those routes learned from the Exterior Gateway Protocol (EGP), like BGP, and is passed transparently throughout the AS. This data is kept separate from the OSPF protocol's link state data. Each external route can be tagged by the advertising router, enabling the passing of additional information between routers on the boundaries of the AS.

## Authentication

All OSPF protocol exchanges can be authenticated. This means that only trusted routers can participate in autonomous system routing. Alcatel-Lucent's implementation of OSPF supports plain text and Message Digest 5 (MD5) authentication (also called simple password).

MD5 allows an authentication key to be configured per network. Routers in the same routing domain must be configured with the same key. When the MD5 hashing algorithm is used for authentication, MD5 is used to verify data integrity by creating a 128-bit message digest from the data input. It is unique to that data. Alcatel-Lucent's implementation of MD5 allows the migration of an MD5 key by using a key ID for each unique key.

By default, authentication is not enabled on an interface.

### IP Subnets

OSPF enables the flexible configuration of IP subnets. Each distributed OSPF route has a destination and mask. A network mask is a 32-bit number that indicates the range of IP addresses residing on a single IP network/subnet. This specification displays network masks as hexadecimal numbers; for example, the network mask for a class C IP network is displayed as 0xfffff00. Such a mask is often displayed as 255.255.255.0.

Two different subnets with same IP network number have different masks, called variable length subnets. A packet is routed to the longest or most specific match. Host routes are considered to be subnets whose masks are all ones (0xffffffff).

---

### Preconfiguration Recommendations

Prior to configuring OSPF, the router ID must be available. The router ID is a 32-bit number assigned to each router running OSPF. This number uniquely identifies the router within an AS. OSPF routers use the router IDs of the neighbor routers to establish adjacencies. Neighbor IDs are learned when Hello packets are received from the neighbor.

Before configuring OSPF parameters, ensure that the router ID is derived by one of the following methods:

- Define the value in the **config>router** *router-id* context.
- Define the system interface in the **config>router>interface** *ip-int-name* context (used if the router ID is not specified in the **config>router** *router-id* context).  
A system interface must have an IP address with a 32-bit subnet mask. The system interface is used as the router identifier by higher-level protocols such as OSPF and IS-IS. The system interface is assigned during the primary router configuration process when the interface is created in the logical IP interface context.
- If you do not specify a router ID, then the last four bytes of the MAC address are used.

NOTE: On the BGP protocol level, a BGP router ID can be defined in the **config>router>bgp** *router-id* context and is only used within BGP.



## Multiple OSPF Instances

The main route table manager (RTM) can create multiple instances of OSPF by extending the current creation of an instance. A given interface can only be a member of a single OSPF instance. When an interface is configured in a given domain and needs to be moved to another domain the interface must first be removed from the old instance and re-created in the new instance.

---

## Route Export Policies for OSPF

Route policies allow specification of the source OSPF process ID in the **from** and **to** parameters in the **config>router>policy-options>policy-statement>entry>from** context, for example **from protocol ospf instance-id**.

If an *instance-id* is specified, only routes installed by that instance are picked up for announcement. If no *instance-id* is specified, then only routes installed by the base instance will be announced. The **all** keyword announces routes installed by all instances of OSPF.

When announcing internal (intra/inter-area) OSPF routes from another process, the default type should be type-1, and metric set to the route metric in RTM. For AS-external routes, by default the route type (type-1/2) should be preserved in the originated LSA, and metric set to the route metric in RTM. By default, the tag value should be preserved when an external OSPF route is announced by another process. All these can be changed with explicit action statements.

Export policy should allow a match criteria based on the OSPF route hierarchy, e.g. only intra-area, only inter-area, only external, only internal (intra/inter-area). There must also be a possibility to filter based on existing tag values.

### Preventing Route Redistribution Loops

The legacy method for this was to assign a tag value to each OSPF process and mark each external route originated within that domain with that value. However, since the tag value must be preserved throughout different OSPF domains, this only catches loops that go back to the originating domain and not where looping occurs in a remote set of domains. To prevent this type of loop, the route propagation information in the LSA must be accumulative. The following method has been implemented:

- The OSPF tag field in the AS-external LSAs is treated as a bit mask, rather than a scalar value. In other words, each bit in the tag value can be independently checked, set or reset as part of the routing policy.
- When a set of OSPF domains are provisioned in a network, each domain is assigned a specific bit value in the 32-bit tag mask. When an external route is originated by an ASBR using an internal OSPF route in a given domain, a corresponding bit is set in the AS-external LSA. As the route gets redistributed from one domain to another, more bits are set in the tag mask, each corresponding to the OSPF domain the route visited. Route redistribution looping is prevented by checking the corresponding bit as part of the export policy--if the bit corresponding to the announcing OSPF process is already set, the route is not exported there.

From the CLI perspective, this involves adding a set of **from tag** and **action tag** commands that allow for bit operations.

## IP Fast-reroute (IP FRR) For OSPF and IS-IS Prefixes

This feature provides for the use of the Loop-Free Alternate (LFA) backup next-hop for forwarding in-transit and CPM generated IP packets when the primary next-hop is not available. This means that a node resumes forwarding IP packets to a destination prefix without waiting for the routing convergence.

When any of the following events occurs, IGP instructs in the fast path the IOMs to enable the LFA backup next-hop:

- OSPF/IS-IS interface goes operationally down: physical or local admin shutdown.
- Timeout of a BFD session to a next-hop when BFD is enabled on the OSPF/IS-IS interface

IP FRR is supported on IPv4 OSPF/IS-IS prefixes forwarded in the base router instance to a network IP interface or to an IES SAP interface or spoke interface. It is also supported for VPRN VPN-IPv4 OSPF prefixes forwarded to a VPRN SAP interface or spoke interface. IP FRR also provides a LFA backup next-hop for the destination prefix of a GRE tunnel used in an SDP or in VPRN auto-bind.

The LFA next-hop pre-computation by IGP is described in RFC 5286 – “Basic Specification for IP Fast Reroute: Loop-Free Alternates”.

Refer to [IP Fast-reroute \(IP FRR\) For IS-IS Prefixes on page 453](#) for IP FRR for OSPF prefixes.

---

## IP FRR Configuration

The user first enables Loop-Free Alternate (LFA) computation by SPF under the IS-IS routing protocol level or under the OSPF routing protocol instance level:

```
config>router>isis>loopfree-alternate
config>router>ospf>loopfree-alternate
config>service>vprn>ospf>loopfree-alternate
```

The above commands instruct the IGP SPF to attempt to pre-compute both a primary next-hop and an LFA next-hop for every learned prefix. When found, the LFA next-hop is populated into the RTM along with the primary next-hop for the prefix.

Next the user enables IP FRR to cause RTM to download to IOM a LFA next-hop, when found by SPF, in addition to the primary next-hop for each prefix in the FIB.

```
config>router>ip-fast-reroute
```

### Reducing the Scope of the LFA Calculation by SPF

The user can instruct IGP to not include all interfaces participating in a specific IS-IS level or OSPF area in the SPF LFA computation. This provides a way of reducing the LFA SPF calculation where it is not needed.

```
config>router>isis>level>loopfree-alternate-exclude
```

```
config>router>ospf>area>loopfree-alternate-exclude
```

The user can also exclude a specific IP interface from being included in the LFA SPF computation by IS-IS or OSPF:

```
config>router>isis>interface> loopfree-alternate-exclude
```

```
config>router>ospf>area>interface> loopfree-alternate-exclude
```

Note that when an interface is excluded from the LFA SPF in IS-IS, it is excluded in both level 1 and level 2. When the user excludes an interface from the LFA SPF in OSPF, it is excluded in all areas. However, the above OSPF command can only be executed under the area in which the specified interface is primary and once enabled, the interface is excluded in that area and in all other areas where the interface is secondary. If the user attempts to apply it to an area where the interface is secondary, the command will fail.

Finally, the user can apply the same above commands for an OSPF instance within a VPRN service:

```
config>service>vprn>ospf>area>loopfree-alternate-exclude
```

```
config>service>vprn>ospf>area>interface>loopfree-alternate-exclude
```

---

### ECMP Considerations

Whenever the SPF computation determined there is more than one primary next-hop for a prefix, it will not program any LFA next-hop in RTM. Thus, IP prefixes will resolve to the multiple primary next-hops in this case which provides the required protection.

---

### IP FRR and RSVP Shortcut (IGP Shortcut)

IGP shortcuts are not supported in the LFA next-hop calculation.

## OSPF and IS-IS Support for Loop-Free Alternate Calculation

SPF computation in IS-IS and OSPF is enhanced to compute LFA alternate routes for each learned prefix and populate it in RTM.

Figure 11 illustrates a simple network topology with point-to-point (P2P) interfaces and highlights three routes to reach router R5 from router R1.

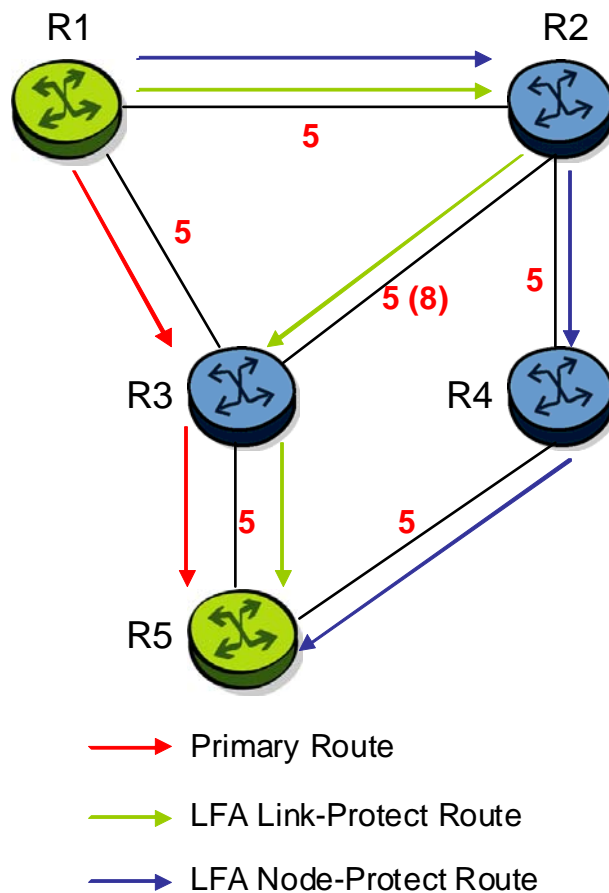

**Figure 11: Example Topology with Primary and LFA Routes**

The primary route is via R3. The LFA route via R2 has two equal cost paths to reach R5. The path via R3 protects against failure of link R1-R3. This route is computed by R1 by checking that the cost for R2 to reach R5 via R3 is lower than the cost via routes R1 and R3. This condition is referred to as the “loop-free criterion”.

The path via R2 and R4 can be used to protect against the failure of router R3. However, with the link R2-R3 metric set to 5, R2 sees the same cost to forward a packet to R5 via R3 and R4. Thus R1 cannot guarantee that enabling the LFA next-hop R2 will protect against R3 node failure. This

## Configuring OSPF

means that the LFA next-hop R2 provides link-protection only for prefix R5. If the metric of link R2-R3 is changed to 8, then the LFA next-hop R2 provides node protection since a packet to R5 will always go over R4.

Consider now the case where the primary next-hop uses a broadcast interface as illustrated in [Figure 12](#).

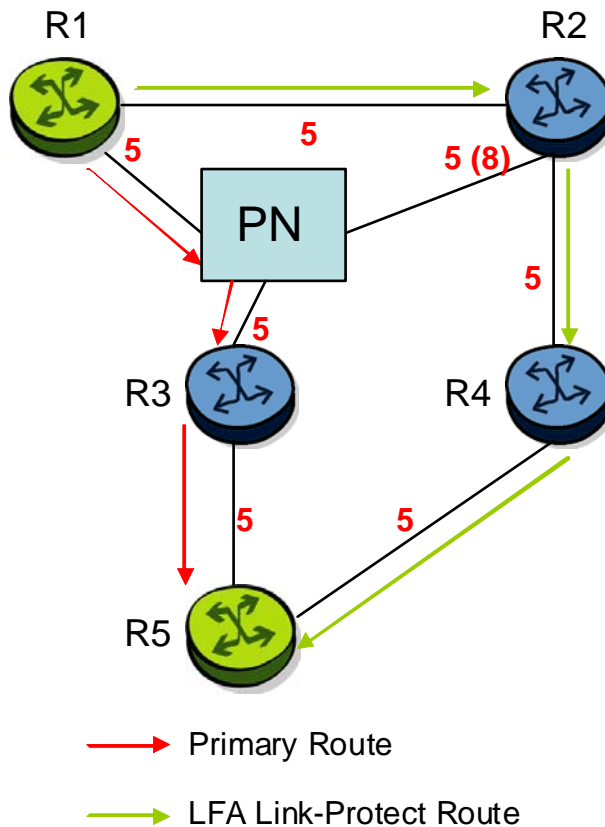

**Figure 12: Example Topology with Broadcast Interfaces**

In order for next-hop R2 to be a link-protect LFA for route R5 from R1, it must be loop-free with respect to the R1-R3 link's Pseudo-Node (PN). However, since R2 has also a link to that PN, its cost to reach R5 via the PN or router R4 are the same. Thus R1 cannot guarantee that enabling the LFA next-hop R2 will protect against a failure impacting link R1-PN since this may cause the entire subnet represented by the PN to go down. If the metric of link R2-PN is changed to 8, then R2 next-hop will be an LFA providing link protection.

The following are the detailed equations for this criterion as provided in RFC 5286, *Basic Specification for IP Fast Reroute: Loop-Free Alternates*:

- Link-protect backup next-hop (primary next-hop R1-R3 is a P2P interface):  

$$\text{Distance\_opt}(R2, R5) < \text{Distance\_opt}(R2, R1) + \text{Distance\_opt}(R1, R5)$$
- Node-protect backup next-hop (primary next-hop R1-R3 is a P2P interface):  

$$\text{Distance\_opt}(R2, R5) < \text{Distance\_opt}(R2, R3) + \text{Distance\_opt}(R3, R5)$$
- Link-protect backup next-hop (primary next-hop R1-R3 is a broadcast interface):  

$$\text{Distance\_opt}(R2, R5) < \text{Distance\_opt}(R2, \text{PN}) + \text{Distance\_opt}(\text{PN}, R5)$$

Where PN stands for the R1-R3 link's Pseudo-Node.

For the case of P2P interface, if SPF finds multiple LFA next-hops for a given primary next-hop, it follows the following selection algorithm:

- A) It will pick the node-protect type in favor of the link-protect type.
- B) If there is more than one LFA next-hop within the selected type, then it will pick one based on the least cost.
- C) If more than one LFA next-hop with the same cost results from step (b), then SPF will select the first one. This is not a deterministic selection and will vary following each SPF calculation.

For the case of a broadcast interface, a node-protect LFA is not necessarily a link protect LFA if the path to the LFA next-hop goes over the same PN as the primary next-hop. Similarly, a link protect LFA may not guarantee link protection if it goes over the same PN as the primary next-hop. The selection algorithm when SPF finds multiple LFA next-hops for a given primary next-hop is modified as follows:

- A) The algorithm splits the LFA next-hops into two sets:
  - The first set consists of LFA next-hops which do not go over the PN used by primary next-hop,
  - The second set consists of LFA next-hops which go over the PN used by the primary next-hop.
- B) If there is more than one LFA next-hop in the first set, it will pick the node-protect type in favor of the link-protect type.
- C) If there is more than one LFA next-hop within the selected type, then it will pick one based on the least cost.
- D) If more than one LFA next-hop with equal cost results from step (c), SPF will select the first one from the remaining set. This is not a deterministic selection and will vary following each SPF calculation.

## Configuring OSPF

E) If no LFA next-hop results from step (d), SPF will rerun steps (b-d) using the second set.

Note this algorithm is more flexible than strictly applying the link protect rule in the presence of a PN and specified in 5286. A node-protect LFA which does not avoid the PN, i.e., does not guarantee link protection, can still be selected as a last resort. The same thing, a link-protect LFA which does not avoid the PN may still be selected as a last resort.

---

### **Loop-Free Alternate Calculation for Inter-Area/inter-Level Prefixes**

When SPF resolves OSPF inter-area prefixes or IS-IS inter-level prefixes, it will compute an LFA backup next-hop to the same exit area/border router as used by the primary next-hop.



## OSPF Configuration Process Overview

Figure 13 displays the process to provision basic OSPF parameters.

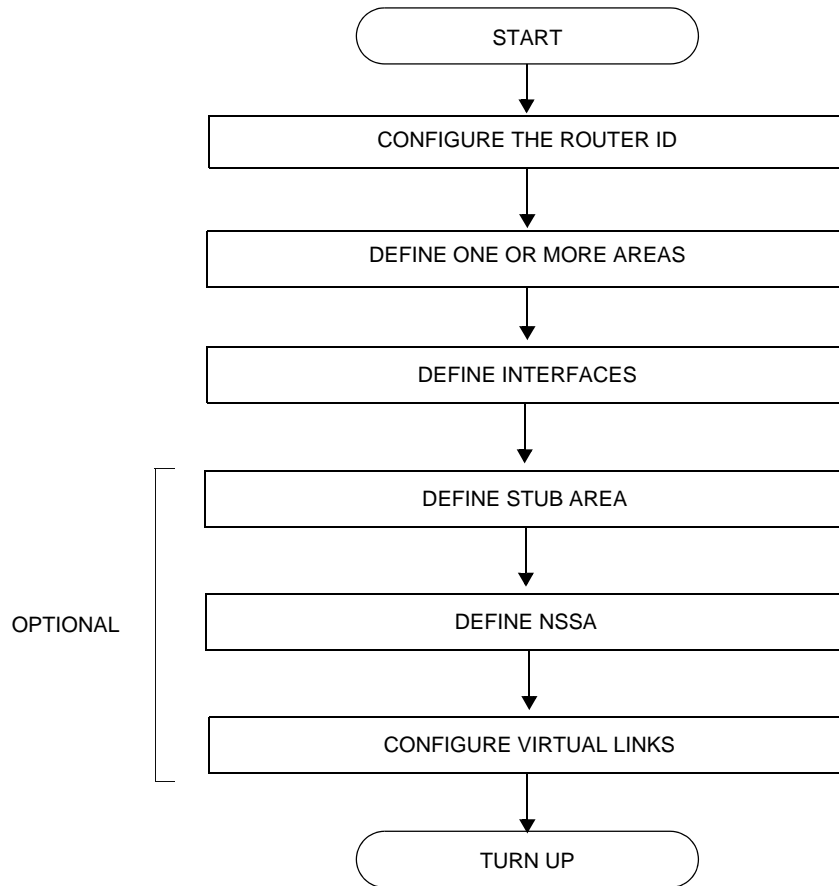

Figure 13: OSPF Configuration and Implementation Flow

## Configuration Notes

This section describes OSPF configuration caveats.

---

### General

- Before OSPF can be configured, the router ID must be configured.
  - The basic OSPF configuration includes at least one area and an associated interface.
  - All default and command parameters can be modified.
- 

### OSPF Defaults

The following list summarizes the OSPF configuration defaults:

- By default, a router has no configured areas.
- An OSPF instance is created in the administratively enabled state.

## Configuring OSPF with CLI

This section provides information to configure Open Shortest Path First (OSPF) using the command line interface.

Topics in this section include:

- [OSPF Configuration Guidelines on page 316](#)
- [Basic OSPF Configuration on page 317](#)
- [Configuring the Router ID on page 318](#)
- [Configuring OSPF Components on page 319](#)
  - [Configuring the Router ID on page 318](#)
  - [Configuring an OSPF or OSPF3 Area on page 321](#)
  - [Configuring a Stub Area on page 322](#)
  - [Configuring a Not-So-Stubby Area on page 324](#)
  - [Configuring a Virtual Link on page 326](#)
  - [Configuring an Interface on page 328](#)
  - [Configuring Authentication on page 331](#)
  - [Assigning a Designated Router on page 334](#)
  - [Configuring Route Summaries on page 336](#)
  - [Configuring Route Preferences on page 338](#)
- [OSPF Configuration Management Tasks on page 341](#)
  - [Modifying a Router ID on page 341](#)
  - [Deleting a Router ID on page 343](#)
  - [Modifying OSPF Parameters on page 344](#)

## OSPF Configuration Guidelines

Configuration planning is essential to organize routers, backbone, non-backbone, stub, NSSA areas, and transit links. OSPF provides essential defaults for basic protocol operability. You can configure or modify commands and parameters. OSPF is not enabled by default.

The minimal OSPF parameters which should be configured to deploy OSPF are:

- Router ID

Each router running OSPF must be configured with a unique router ID. The router ID is used by both OSPF and BGP routing protocols in the routing table manager.

When configuring a new router ID, protocols will not automatically be restarted with the new router ID. Shut down and restart the protocol to initialize the new router ID.

- OSPF Instance

OSPF instances must be defined when configuring multiple instances and/or the instance being configured is not the base instance.

- An area

At least one OSPF area must be created. An interface must be assigned to each OSPF area.

- Interfaces

An interface is the connection between a router and one of its attached networks. An interface has state information associated with it, which is obtained from the underlying lower level protocols and the routing protocol itself. An interface to a network has associated with it a single IP address and mask (unless the network is an unnumbered point-to-point network). An interface is sometimes also referred to as a link.

## Basic OSPF Configuration

This section provides information to configure OSPF and OSPF3 as well as configuration examples of common configuration tasks.

The minimal OSPF parameters that need to be configured are:

- A router ID - If a *router-id* is not configured in the `config>router` context, the router's system interface IP address is used.
- One or more areas.
- Interfaces (`interface "system"`).

Following is an example of a basic OSPF configuration:

```
ALA-A>config>router>ospf# info

 area 0.0.0.0
 interface "system"
 exit
 exit
 area 0.0.0.20
 nssa
 exit
 interface "to-104"
 priority 10
 exit
 exit
 area 0.0.1.1
 exit

ALA-A>config>router>ospf#
A:ALA-48>config>router>ospf3# info

 asbr
 overload
 timers
 lsa-arrival 50000
 exit
 export "OSPF-Export"
 area 0.0.0.0
 interface "system"
 exit
 exit
 area 0.0.0.20
 nssa
 exit
 interface "SR1-2"
 exit
 exit
 area 0.0.0.25
 stub
 default-metric 5000
 exit
 exit
```

## Configuring the Router ID

The router ID uniquely identifies the router within an AS. In OSPF, routing information is exchanged between autonomous systems, groups of networks that share routing information. It can be set to be the same as the loopback (system interface) address. Subscriber services also use this address as far-end router identifiers when service distribution paths (SDPs) are created. The router ID is used by both OSPF and BGP routing protocols. A router ID can be derived by:

- Defining the value in the `config>router router-id` context.
- Defining the system interface in the `config>router>interface ip-int-name` context (used if the router ID is not specified in the `config>router router-id` context).
- Inheriting the last four bytes of the MAC address.
- On the BGP protocol level. A BGP router ID can be defined in the `config>router>bgp router-id` context and is only used within BGP.

When configuring a new router ID, protocols are not automatically restarted with the new router ID. The next time a protocol is (re) initialized the new router ID is used. An interim period of time can occur when different protocols use different router IDs. To force the new router ID, issue the `shutdown` and `no shutdown` commands for each protocol that uses the router ID or restart the entire router.

The following displays a router ID configuration example:

```
A:ALA-B>config>router# info
#-----
IP Configuration
#-----
 interface "system"
 address 10.10.10.104/32
 exit
 interface "to-103"
 address 10.0.0.104/24
 port 1/1/1
 exit
 autonomous-system 100
 router-id 10.10.10.104
...
#-----
A:ALA-B>config>router#
```

## Configuring OSPF Components

Use the CLI syntax displayed below for:

- [Configuring OSPF Parameters on page 319](#)
  - [Configuring OSPF3 Parameters on page 320](#)
  - [Configuring a Stub Area on page 322](#)
  - [Configuring a Not-So-Stubby Area on page 324](#)
  - [Configuring a Virtual Link on page 326](#)
  - [Configuring an Interface on page 328](#)
  - [Configuring Authentication on page 331](#)
  - [Assigning a Designated Router on page 334](#)
  - [Configuring Route Summaries on page 336](#)
- 

## Configuring OSPF Parameters

The following displays a basic OSPF configuration example:

```
A:ALA-49>config>router>ospf# info

 asbr
 overload
 overload-on-boot timeout 60
 traffic-engineering
 export "OSPF-Export"
 graceful-restart
 helper-disable
 exit

A:ALA-49>config>router>ospf# ex
```

## Configuring OSPF3 Parameters

Use the following CLI syntax to configure OSPF3 parameters:

```
CLI Syntax: config>router# ospf3
 asbr
 export policy-name [policy-name...(upto 5 max)]
 external-db-overflow limit seconds
 external-preference preference
 overload [timeout seconds]
 overload-include-stub
 overload-on-boot [timeout seconds]
 preference preference
 reference-bandwidth bandwidth-in-kbps
 router-id ip-address
 no shutdown
 timers
 lsa-arrival lsa-arrival-time
 lsa-generate max-lsa-wait
 spf-wait max-spf-wait [spf-initial-wait [spf-second-wait]]
```

The following displays an OSPF3 configuration example :

```
A:ALA-48>config>router>ospf3# info

 asbr
 overload
 timers
 lsa-arrival 50000
 exit
 export "OSPF-Export"

A:ALA-48>config>router>ospf3#
```



## Configuring an OSPF or OSPF3 Area

An OSPF area consists of routers configured with the same area ID. To include a router in a specific area, the common area ID must be assigned and an interface identified.

If your network consists of multiple areas you must also configure a backbone area (0.0.0.0) on at least one router. The backbone is comprised of the area border routers and other routers not included in other areas. The backbone distributes routing information between areas. The backbone is considered to be a participating area within the autonomous system. To maintain backbone connectivity, there must be at least one interface in the backbone area or have a virtual link configured to another router in the backbone area.

The minimal configuration must include an area ID and an interface. Modifying other command parameters are optional.

Use the following CLI syntax to configure an OSPF or OSPF3 area:

```
CLI Syntax: ospf ospf-instance
 ospf3
 area area-id
 area-range ip-prefix/mask [advertise|not-advertise]
 blackhole-aggregate
```

The following displays an OSPF area configuration example:

```
A:ALA-A>config>router>ospf# info

 area 0.0.0.0
 exit
 area 0.0.0.20
 exit

ALA-A>config>router>ospf#A:
```

## Configuring a Stub Area

Configure stub areas to control external advertisements flooding and to minimize the size of the topological databases on an area's routers. A stub area cannot also be configured as an NSSA.

By default, summary route advertisements are sent into stub areas. The **no** form of the summary command disables sending summary route advertisements and only the default route is advertised by the ABR. This example retains the default so the command is not entered.

If this area is configured as a transit area for a virtual link, then existing virtual links of a non-stub or NSSA area are removed when its designation is changed to NSSA or stub.

Stub areas for OSPF3 are configured the same as OSPF stub areas.

Use the following CLI syntax to configure virtual links:

**CLI Syntax:**

```
ospf
ospf3
area area-id
stub
default-metric metric
summaries
```

The following displays a stub configuration example:

```
ALA-A>config>router>ospf>area># info

...
area 0.0.0.0
exit
area 0.0.0.20
 stub
 exit
exit
...

ALA-A>config>router>ospf#
```

The following displays a stub configuration example:

```
ALA-A>config>router>ospf>area># info

...
area 0.0.0.0
exit
area 0.0.0.20
 stub
 exit
exit
...

```

```
ALA-A>config>router>ospf#
```

```
A:ALA-48>config>router>ospf3>area# info
```

```

 stub
 default-metric 5000
 exit

```

```
A:ALA-48>config>router>ospf3>area#
```

## Configuring a Not-So-Stubby Area

You must explicitly configure an area to be a Not-So-Stubby Area (NSSA) area. NSSAs are similar to stub areas in that no external routes are imported into the area from other OSPF areas. The major difference between a stub area and an NSSA is an NSSA has the capability to flood external routes it learns throughout its area and by an area border router to the entire OSPF domain. An area cannot be both a stub area and an NSSA.

If this area is configured as a transit area for a virtual link, then existing virtual links of a non-stub or NSSA area are removed when its designation is changed to NSSA or stub.

Use the following CLI syntax to configure stub areas:

```
CLI Syntax: ospf ospf-instance
 ospf3
 area area-id
 nssa
 area-range ip-prefix/mask [advertise|not-advertise]
 originate-default-route [type-7]
 redistribute-external
 summaries
```

The following displays an NSSA configuration example:

```
A:ALA-49>config>router>ospf# info

asbr
overload
overload-on-boot timeout 60
traffic-engineering
export "OSPF-Export"
graceful-restart
 helper-disable
exit
area 0.0.0.0
exit
area 0.0.0.20
 stub
 exit
exit
area 0.0.0.25
 nssa
 exit
exit

A:ALA-49>config>router>ospf#
```

The following displays a OSPF3 NSSA configuration example:

```
A:ALA-48>config>router>ospf3# info
```

```

asbr
overload
timers
 lsa-arrival 50000
exit
export "OSPF-Export"
area 0.0.0.0
exit
area 0.0.0.20
 stub
 exit
exit
area 0.0.0.25
 nssa
 exit
exit
area 4.3.2.1
exit

```

```
A:ALA-48>config>router>ospf3#
```

## Configuring a Virtual Link

The backbone area (area 0.0.0.0) must be contiguous and all other areas must be connected to the backbone area. If it is not practical to connect an area to the backbone then the area border routers must be connected via a virtual link. The two area border routers will form a point-to-point-like adjacency across the transit area. A virtual link can only be configured while in the area 0.0.0.0 context.

The `router-id` parameter specified in the `virtual-link` command must be associated with the virtual neighbor, that is, enter the virtual neighbor's router ID, not the local router ID. The transit area cannot be a stub area or an NSSA.

Use the following CLI syntax to configure stub areas:

```
CLI Syntax: ospf ospf-instance
 area area-id
 virtual-link router-id transit-area area-id
 authentication-key [authentication-key|hash-key]
 [hash]
 authentication-type [password|message-digest]

 dead-interval seconds
 hello-interval seconds
 message-digest-key key-id md5 [key|hash-key]
 [hash|hash2]
 retransmit-interval seconds
 transit-delay
 no shutdown
```

The following displays a virtual link configuration example:

```
A:ALA-49>config>router>ospf# info

asbr
overload
overload-on-boot timeout 60
traffic-engineering
export "OSPF-Export"
graceful-restart
 helper-disable
exit
area 0.0.0.0
 virtual-link 1.2.3.4 transit-area 1.2.3.4
 hello-interval 9
 dead-interval 40
 exit
exit
area 0.0.0.20
 stub
 exit
exit
area 0.0.0.25
```

```
 nssa
 exit
 exit
 area 1.2.3.4
 exit
```

```

A:ALA-49>config>router>ospf#
```

The following displays an OSPF3 virtual link configuration example:

```
A:ALA-48>config>router>ospf3# info
```

```

 asbr
 overload
 timers
 lsa-arrival 50000
 exit
 export "OSPF-Export"
 area 0.0.0.0
 virtual-link 4.3.2.1 transit-area 4.3.2.1
 exit
 exit
 area 0.0.0.20
 stub
 exit
 exit
 area 0.0.0.25
 nssa
 exit
 exit
 area 4.3.2.1
 exit
```

```

A:ALA-48>config>router>ospf3#
```

## Configuring an Interface

In OSPF, an interface can be configured to act as a connection between a router and one of its attached networks. An interface includes state information that was obtained from underlying lower level protocols and from the routing protocol itself. An interface to a network is associated with a single IP address and mask (unless the network is an unnumbered point-to-point network). If the address is merely changed, then the OSPF configuration is preserved.

The `passive` command enables the passive property to and from the OSPF interface where passive interfaces are advertised as OSPF interfaces but do not run the OSPF protocol. By default, only interface addresses that are configured for OSPF are advertised as OSPF interfaces. The `passive` parameter allows an interface to be advertised as an OSPF interface without running the OSPF protocol. When enabled, the interface will ignore ingress OSPF protocol packets and not transmit any OSPF protocol packets.

An interface can be part of more than one area, as specified in RFC5185. To do this, add the keyword **secondary** when creating the interface.

Use the following CLI syntax to configure an OSPF interface:

```
CLI Syntax: ospf ospf-instance
 area area-id
 interface ip-int-name
 advertise-subnet
 authentication-key [authentication-key|hash-key]
 [hash|hash2]
 authentication-type [password|message-digest]
 bfd-enable
 dead-interval seconds
 hello-interval seconds
 interface-type {broadcast|point-to-point}
 message-digest-key key-id md5 [key|hash-
 key] [hash|hash2]
 metric metric
 mtu bytes
 passive
 priority number
 retransmit-interval seconds
 no shutdown
 transit-delay seconds
```

The following displays an interface configuration example:

```
A:ALA-49>config>router>ospf# info

asbr
overload
overload-on-boot timeout 60
```



```

traffic-engineering
export "OSPF-Export"
graceful-restart
 helper-disable
exit
area 0.0.0.0
 virtual-link 1.2.3.4 transit-area 1.2.3.4
 hello-interval 9
 dead-interval 40
 exit
 interface "system"
 exit
exit
area 0.0.0.20
 stub
 exit
 interface "to-103"
 exit
exit
area 0.0.0.25
 nssa
 exit
exit
area 1.2.3.4
exit
area 4.3.2.1
 interface "SR1-3"
 exit
exit
area 4.3.2.1
 interface "SR1-3" secondary
 exit
exit

```

```

A:ALA-49>config>router>ospf# area 0.0.0.20

```

The following displays an interface configuration:

```

A:ALA-48>config>router>ospf3# info

```

```

asbr
overload
timers
 lsa-arrival 50000
exit
export "OSPF-Export"
area 0.0.0.0
 virtual-link 4.3.2.1 transit-area 4.3.2.1
 exit
 interface "system"
 exit
exit
area 0.0.0.20
 stub
 exit
 interface "SR1-2"
 exit
exit

```

## Configuring OSPF Components

```
area 0.0.0.25
 nssa
 exit
exit
area 4.3.2.1
exit
```

```

A:ALA-48>config>router>ospf3#
```

## Configuring Authentication

Authentication must be explicitly configured. This feature is not available in the OSPF3 context. The following authentication commands can be configured on the interface level or the virtual link level:

- `authentication-key` — Configures the password used by the OSPF interface or virtual-link to send and receive OSPF protocol packets on the interface when simple password authentication is configured.
- `authentication-type` — Enables authentication and specifies the type of authentication to be used on the OSPF interface, either password or message digest.
- `message-digest-key` — Use this command when `message-digest` keyword is selected in the `authentication-type` command. The Message Digest 5 (MD5) hashing algorithm is used for authentication. MD5 is used to verify data integrity by creating a 128-bit message digest from the data input. It is unique to that specific data.

An special checksum is included in transmitted packets and are used by the far-end router to verify the packet by using an authentication key (a password). Routers on both ends must use the same MD5 key.

MD5 can be configured on each interface and each virtual link. If MD5 is enabled on an interface, then that interface accepts routing updates only if the MD5 authentication is accepted. Updates that are not authenticated are rejected. A router accepts only OSPF packets sent with the same `key-id` value defined for the interface.

When the `hash` parameter is not used, non-encrypted characters can be entered. Once configured using the `message-digest-key` command, then all keys specified in the command are stored in encrypted format in the configuration file using the `hash` keyword. When using the `hash` keyword the password must be entered in encrypted form. Hashing cannot be reversed. Issue the `no message-digest-key key-id` command and then re-enter the command *without* the `hash` parameter to configure an unhashed key.

The following CLI commands are displayed to illustrate the key authentication features. These command parameters can be defined at the same time interfaces and virtual-links are being configured. See [Configuring an Interface on page 328](#) and [Configuring a Virtual Link on page 326](#).

Use the following CLI syntax to configure authentication:

```
CLI Syntax: ospf ospf-instance
 area area-id
 interface ip-int-name
 authentication-key [authentication-key|hash-key]
 [hash]
 authentication-type [password|message-digest]
 message-digest-key key-id md5 key [hash]
```

## Configuring OSPF Components

```
virtual-link router-id transit-area area-id
 authentication-key [authentication-key|hash-key]
 [hash]
 authentication-type [password|message-digest]
 message-digest-key key-id md5 key [hash]
```

The following displays authentication configuration examples:

```
A:ALA-49>config>router>ospf# info

asbr
overload
overload-on-boot timeout 60
traffic-engineering
export "OSPF-Export"
graceful-restart
 helper-disable
exit
area 0.0.0.0
 virtual-link 1.2.3.4 transit-area 1.2.3.4
 hello-interval 9
 dead-interval 40
 exit
 interface "system"
 exit
exit
area 0.0.0.20
 stub
 exit
 interface "to-103"
 exit
exit
area 0.0.0.25
 nssa
 exit
exit
area 0.0.0.40
 interface "test1"
 authentication-type password
 authentication-key "3WErEDozxyQ" hash
 exit
exit
area 1.2.3.4
exit

A:ALA-49>config>router>ospf#
```

```
A:ALA-49>config>router>ospf# info

asbr
overload
overload-on-boot timeout 60
traffic-engineering
export "OSPF-Export"
```

```
graceful-restart
 helper-disable
exit
area 0.0.0.0
 virtual-link 10.0.0.1 transit-area 0.0.0.1
 authentication-type message-digest
 message-digest-key 2 md5 "Mi6BQAFi3MI" hash
 exit
 virtual-link 1.2.3.4 transit-area 1.2.3.4
 hello-interval 9
 dead-interval 40
 exit
 interface "system"
 exit
exit
area 0.0.0.1
exit
area 0.0.0.20
 stub
 exit
 interface "to-103"
 exit
exit
area 0.0.0.25
 nssa
 exit
exit
area 0.0.0.40
 interface "test1"
 authentication-type password
 authentication-key "3WErEDozxyQ" hash
 exit
exit
area 1.2.3.4
exit
```

```

A:ALA-49>config>router>ospf#
```

## Assigning a Designated Router

A designated router is elected according to the priority number advertised by the routers. When a router starts up, it checks for a current designated router. If a designated router is present, then the router accepts that designated router, regardless of its own priority designation. When a router fails, then new designated and backup routers are elected according to their priority numbers.

The **priority** command is only used if the interface is a broadcast type. The designated router is responsible for flooding network link advertisements on a broadcast network to describe the routers attached to the network. A router uses hello packets to advertise its priority. The router with the highest priority interface becomes the designated router. A router with priority 0 is not eligible to be a designated router or a backup designated router. At least one router on each logical IP network or subnet must be eligible to be the designated router. By default, routers have a priority value of 1.

Use the following CLI syntax to configure the designated router:

```
CLI Syntax: ospf ospf-instance
 area area-id
 interface ip-int-name
 priority number
```

The following displays a priority designation example:

```
A:ALA-49>config>router>ospf# info

asbr
overload
overload-on-boot timeout 60
traffic-engineering
export "OSPF-Export"
graceful-restart
 helper-disable
exit
area 0.0.0.0
 virtual-link 10.0.0.1 transit-area 0.0.0.1
 authentication-type message-digest
 message-digest-key 2 md5 "Mi6BQAFi3MI" hash
 exit
 virtual-link 1.2.3.4 transit-area 1.2.3.4
 hello-interval 9
 dead-interval 40
 exit
 interface "system"
 exit
exit
area 0.0.0.1
exit
area 0.0.0.20
 stub
 exit
 interface "to-103"
```

```
 exit
 exit
 area 0.0.0.25
 nssa
 exit
 interface "if2"
 priority 100
 exit
 exit
 area 0.0.0.40
 interface "test1"
 authentication-type password
 authentication-key "3WErEDozxyQ" hash
 exit
 exit
 area 1.2.3.4
 exit
```

```

A:ALA-49>config>router>ospf#
```

## Configuring Route Summaries

Area border routers send summary (type 3) advertisements into a stub area or NSSA to describe the routes to other areas. This command is particularly useful to reduce the size of the routing and Link State Database (LSDB) tables within the stub or NSSA.

By default, summary route advertisements are sent into the stub area or NSSA. The `no` form of the `summaries` command disables sending summary route advertisements and, in stub areas, the default route is advertised by the area border router.

The following CLI commands are displayed to illustrate route summary features. These command parameters can be defined at the same time stub areas and NSSAs are being configured. See [Configuring a Stub Area on page 322](#) and [Configuring a Not-So-Stubby Area on page 324](#).

Use the following CLI syntax to configure a route summary:

```
CLI Syntax: ospf ospf-instance
 area area-id
 stub
 summaries
 nssa
 summaries
```

The following displays a stub route summary configuration example:

```
A:ALA-49>config>router>ospf# info

asbr
overload
overload-on-boot timeout 60
traffic-engineering
export "OSPF-Export"
graceful-restart
 helper-disable
exit
area 0.0.0.0
 virtual-link 10.0.0.1 transit-area 0.0.0.1
 authentication-type message-digest
 message-digest-key 2 md5 "Mi6BQAFi3MI" hash
 exit
 virtual-link 1.2.3.4 transit-area 1.2.3.4
 hello-interval 9
 dead-interval 40
 exit
 interface "system"
 exit
exit
area 0.0.0.1
exit
area 0.0.0.20
 stub
```



```
 exit
 interface "to-103"
 exit
 exit
 area 0.0.0.25
 nssa
 exit
 interface "if2"
 priority 100
 exit
 exit
 area 0.0.0.40
 interface "test1"
 authentication-type password
 authentication-key "3WErEDoZxyQ" hash
 exit
 exit
 area 1.2.3.4
 exit
```

```

A:ALA-49>config>router>ospf#
```

```
A:ALA-48>config>router>ospf3# info
```

```

asbr
overload
timers
 lsa-arrival 50000
exit
export "OSPF-Export"
area 0.0.0.0
 virtual-link 4.3.2.1 transit-area 4.3.2.1
 exit
 interface "system"
 exit
exit
area 0.0.0.20
 stub
 exit
 interface "SR1-2"
 exit
exit
area 0.0.0.25
 nssa
 exit
exit
area 4.3.2.1
exit
```

```

A:ALA-48>config>router>ospf3#
```

## Configuring Route Preferences

A route can be learned by the router from different protocols, in which case, the costs are not comparable. When this occurs the preference value is used to decide which route is installed in the forwarding table if several protocols calculate routes to the same destination. The route with the lowest preference value is selected.

Different protocols should not be configured with the same preference, if this occurs the tiebreaker is per the default preference table as defined in [Table 9](#). If multiple routes are learned with an identical preference using the same protocol, the lowest cost route is used.

**Table 9: Route Preference Defaults by Route Type**

| Route Type             | Preference | Configurable     |
|------------------------|------------|------------------|
| Direct attached        | 0          | No               |
| Static routes          | 5          | Yes              |
| OSPF internal          | 10         | Yes <sup>a</sup> |
| IS-IS level 1 internal | 15         | Yes              |
| IS-IS level 2 internal | 18         | Yes              |
| OSPF external          | 150        | Yes              |
| IS-IS level 1 external | 160        | Yes              |
| IS-IS level 2 external | 165        | Yes              |
| BGP                    | 170        | Yes              |

a. Preference for OSPF internal routes is configured with the **preference** command.

If multiple routes are learned with an identical preference using the same protocol and the costs (metrics) are equal, then the decision of what route to use is determined by the configuration of the **ecmp** in the **config>router** context.

The following CLI commands are displayed to illustrate route preference features. The command parameters can be defined at the same time you are configuring OSPF. See [Configuring OSPF Components on page 319](#).

Use the following CLI syntax to configure a route preference:

**CLI Syntax:** `ospf ospf-instance`  
`ospf3`  
`preference preference`  
`external-preference preference`

The following displays a route preference configuration example:

```
A:ALA-49>config>router>ospf# info

asbr
overload
overload-on-boot timeout 60
traffic-engineering
preference 9
external-preference 140
export "OSPF-Export"
graceful-restart
 helper-disable
exit
area 0.0.0.0
 virtual-link 10.0.0.1 transit-area 0.0.0.1
 authentication-type message-digest
 message-digest-key 2 md5 "Mi6BQAFi3MI" hash
 exit
 virtual-link 1.2.3.4 transit-area 1.2.3.4
 hello-interval 9
 dead-interval 40
 exit
 interface "system"
 exit
exit
area 0.0.0.1
exit
area 0.0.0.20
 stub
 exit
 interface "to-103"
 exit
exit
area 0.0.0.25
 nssa
 exit
 interface "if2"
 priority 100
 exit
exit
area 0.0.0.40
 interface "test1"
 authentication-type password
 authentication-key "3WErEDozxyQ" hash
 exit
exit
area 1.2.3.4
exit
```

## Configuring OSPF Components

-----  
The following displays a route preference configuration example:

```
A:ALA-48>config>router>ospf3# info
```

```

asbr
overload
timers
 lsa-arrival 50000
exit
preference 9
external-preference 140
export "OSPF-Export"
area 0.0.0.0
 virtual-link 4.3.2.1 transit-area 4.3.2.1
 exit
 interface "system"
 exit
exit
area 0.0.0.20
 stub
 exit
 interface "SR1-2"
 exit
exit
area 0.0.0.25
 nssa
 exit
exit
area 4.3.2.1
exit
```

```

A:ALA-48>config>router>ospf3#
```

## OSPF Configuration Management Tasks

This section discusses the following OSPF configuration management tasks:

- [Modifying a Router ID on page 341](#)
- [Deleting a Router ID on page 343](#)
- [Modifying OSPF Parameters on page 344](#)

### Modifying a Router ID

Since the router ID is defined in the `config>router` context, not in the OSPF configuration context, the protocol instance is not aware of the change. Re-examine the plan detailing the router ID. Changing the router ID on a device could cause configuration inconsistencies if associated values are not also modified.

After you have changed a router ID, manually shut down and restart the protocol using the `shutdown` and `no shutdown` commands in order for the changes to be incorporated.

Use the following CLI syntax to change a router ID number:

**CLI Syntax:** `config>router# router-id router-id`

The following displays a NSSA router ID modification example:

```
A:ALA-49>config>router# info

IP Configuration

 interface "system"
 address 10.10.10.104/32
 exit
 interface "to-103"
 address 10.0.0.103/24
 port 1/1/1
 exit
 autonomous-system 100
 router-id 10.10.10.104

A:ALA-49>config>router#

ALA-48>config>router# info

IP Configuration

 interface "system"
 address 10.10.10.103/32
```

## OSPF Configuration Management Tasks

```
exit
interface "to-104"
 address 10.0.0.104/24
 port 1/1/1
exit
autonomous-system 100
router-id 10.10.10.103

ALA-48>config>router#
```

## Deleting a Router ID

You can modify a router ID, but you cannot delete the parameter. When the `no router router-id` command is issued, the router ID reverts to the default value, the system interface address (which is also the loopback address). If a system interface address is not configured, then the last 32 bits of the chassis MAC address is used as the router ID.

### Modifying OSPF Parameters

You can change or remove existing OSPF parameters in the CLI or NMS. The changes are applied immediately.

The following example displays an OSPF modification in which an interface is removed and another interface added.

**Example:**

```
config>router# ospf 1
config>router>ospf# area 0.0.0.20
config>router>ospf>area# no interface "to-103"
config>router>ospf>area# interface "to-HQ"
config>router>ospf>area>if$ priority 50
config>router>ospf>area>if# exit
config>router>ospf>area# exit
```

The following example displays the OSPF configuration with the modifications entered in the previous example:

```
A:ALA-49>config>router>ospf# info

asbr
overload
overload-on-boot timeout 60
traffic-engineering
preference 9
external-preference 140
export "OSPF-Export"
graceful-restart
 helper-disable
exit
area 0.0.0.0
 virtual-link 10.0.0.1 transit-area 0.0.0.1
 authentication-type message-digest
 message-digest-key 2 md5 "Mi6BQAFi3MI" hash
 exit
 virtual-link 1.2.3.4 transit-area 1.2.3.4
 hello-interval 9
 dead-interval 40
 exit
 interface "system"
 exit
exit
area 0.0.0.1
exit
area 0.0.0.20
 stub
 exit
 interface "to-HQ"
 priority 50
 exit
exit
area 0.0.0.25
```



```
nssa
exit
interface "if2"
 priority 100
exit
exit
area 0.0.0.40
 interface "test1"
 authentication-type password
 authentication-key "3WErEDozxyQ" hash
 exit
exit
area 1.2.3.4
exit
```

```

A:ALA-49>config>router>ospf#
```



---

# OSPF Command Reference

---

## Command Hierarchies

- [Configuration Commands on page 347](#)
- [Show Commands on page 350](#)
- [Clear Commands on page 350](#)
- [Debug Commands on page 350](#)

## Configuration Commands

```

config
 — router
 — [no] ospf [ospf-instance]
 — [no] ospf3
 — [no] advertise-tunnel-links
 — [no] area area-id
 — area-range ip-prefix/mask [advertise | not-advertise]
 — no area-range ip-prefix/mask
 — [no] blackhole-aggregate
 — [no] interface ip-int-name [secondary]
 — [no] advertise-subnet
 — authentication-key [authentication-key | hash-key] [hash | hash2]
 — no authentication-key
 — authentication-type {password | message-digest}
 — no authentication-type
 — bfd-enable [remain-down-on-failure]
 — no bfd-enable
 — dead-interval seconds
 — no dead-interval
 — export policy-name [.. policy-name]
 — no export
 — export-limit number [log percentage]
 — no export-limit
 — hello-interval seconds
 — no hello-interval
 — interface-type {broadcast | point-to-point}
 — no interface-type
 — [no] loopfree-alternate-exclude
 — message-digest-key key-id md5 [key | hash-key] [hash | hash2]
 — no message-digest-key key-id
 — metric metric
 — no metric
 — mtu bytes
 — no mtu

```

- [no] **passive**
- **priority** *number*
- **no priority**
- **retransmit-interval** *seconds*
- **no retransmit-interval**
- [no] **shutdown**
- **transit-delay** *seconds*
- **no transit-delay**
- [no] **loopfree-alternate-exclude**
- [no] **nssa**
  - **area-range** *ip-prefix/mask* [**advertise** | **not-advertise**]
  - **no area-range** *ip-prefix/mask*
  - **area-range** *ip-prefix/prefix-length* [**advertise** | **not-advertise**]
  - **no area-range** *ip-prefix/prefix-length*
  - **originate-default-route** [**type-7**]
  - **no originate-default-route**
  - [no] **redistribute-external**
  - [no] **summaries**
- [no] **stub**
  - **default-metric** *metric*
  - **no default-metric**
  - [no] **summaries**
- [no] **virtual-link** *router-id* **transit-area** *area-id*
  - **authentication-key** [*authentication-key* | *hash-key*] [**hash** | **hash2**]
  - **no authentication-key**
  - **authentication-type** {**password** | **message-digest**}
  - **no authentication-type**
  - **dead-interval** *seconds*
  - **no dead-interval**
  - **hello-interval** *seconds*
  - **no hello-interval**
  - **message-digest-key** *key-id* **md5** [*key* | *hash-key*] [**hash** | **hash2**]
  - **no message-digest-key** *key-id*
  - **retransmit-interval** *seconds*
  - **no retransmit-interval**
  - [no] **shutdown**
  - **transit-delay** *seconds*
  - **no transit-delay**
- [no] **asbr** [**trace-path** *domain-id*]
- [no] **compatible-rfc1583**
- [no] **disable-ldp-sync**
- **export** *policy-name* [*policy-name...*(up to 5 max)]
- **no export**
- **export-limit** *number* [**log** *percentage*]
- **no export-limit**
- **external-db-overflow** *limit seconds*
- **no external-db-overflow**
- **external-preference** *preference*
- **no external-preference**
- [no] **graceful-restart**
  - [no] **helper-disable**
- **import** *policy-name* [*policy-name...*(upto 5 max)]
- **no import**
- [no] **ldp-over-rsvp**

- [no] **loopfree-alternate**
- [no] **mcast-import-ipv6**
- [no] **multicast-import**
- **overload** [timeout *seconds*]
- **no overload**
- [no] **overload-include-stub**
- **overload-on-boot** [timeout *seconds*]
- **no overload-on-boot**
- **preference** *preference*
- **no preference**
- **reference-bandwidth** *bandwidth-in-kbps*
- **no reference-bandwidth**
- **router-id** *ip-address*
- **no router-id**
- [no] **rsvp-shortcut**
- [no] **shutdown**
- **timers**
  - [no] **lsa-arrival** *lsa-arrival-time*
  - [no] **lsa-generate** *max-lsa-wait* [*lsa-initial-wait* [*lsa-second-wait*]]
  - [no] **spf-wait** *max-spf-wait* [*spf-initial-wait* [*spf-second-wait*]]
- [no] **traffic-engineering**
- [no] **unicast-import-disable**

## Show Commands

## Show Commands

```
show
 — router
 — ospf [ospf-instance]
 — ospf3
 — area [area-id] [detail][lfa]
 — database [type {router | network | summary | asbr-summary | external | nssa | all}
 [area area-id] [adv-router router-id] [link-state-id] [detail]
 — interface [area area-id] [detail]
 — interface [ip-int-name | ip-address] [detail]
 — lfa-coverage
 — neighbor [remote ip-address] [detail]
 — neighbor [ip-int-name] [router-id] [detail]
 — opaque-database [link link-id | area area-id | as] [adv-router router-id][ls-id] [detail]
 — range [area-id]
 — routes [ip-prefix[/prefix-length]] [type] [detail] [alternative] [summary]
 — spf [lfa]
 — statistics
 — status
 — virtual-link [detail]
 — virtual-neighbor [remote ip-address] [detail]
```

## Clear Commands

```
clear
 — router
 — ospf [ospf-instance]
 — database [purge]
 — export
 — neighbor [ip-int-name | ip-address]
 — statistics
```

## Debug Commands

```
debug
 — router
 — ospf [ospf-instance]
 — ospf3
 — area [area-id]
 — no area
 — area-range [ip-address]
 — no area-range
 — cspf [ip-addr]
 — no cspf
 — [no] graceful-restart
 — interface [ip-int-name | ip-address]
 — no interface
 — leak [ip-address]
 — no leak
```

- **lsdb** [type] [ls-id] [adv-rtr-id] [area area-id]
- **no lsdb**
- [no] **misc**
- **neighbor** [ip-int-name | router-id]
- **no neighbor**
- **nssa-range** [ip-address]
- **no nssa-range**
- **packet** [packet-type] [ip-address]
- **no packet**
- **rtm** [ip-addr]
- **no rtm**
- **spf** [type] [dest-addr]
- **no spf**
- **virtual-neighbor** [ip-address]
- **no virtual-neighbor**





---

## Configuration Commands

---

### Generic Commands

#### shutdown

**Syntax** [no] shutdown

**Context** config>router>ospf  
config>router>ospf3  
config>router>ospf>area>interface  
config>router>ospf3>area>interface  
config>router>ospf>area>virtual-link  
config>router>ospf3>area>virtual-link

**Description** The **shutdown** command administratively disables the entity. When disabled, an entity does not change, reset, or remove any configuration settings or statistics. Many entities must be explicitly enabled using the **no shutdown** command.

The **shutdown** command administratively disables an entity. The operational state of the entity is disabled as well as the operational state of any entities contained within. Many objects must be shut down before they may be deleted.

Unlike other commands and parameters where the default state is not indicated in the configuration file, **shutdown** and **no shutdown** are always indicated in system generated configuration files.

The **no** form of the command puts an entity into the administratively enabled state.

**Default** **OSPF Protocol** — The Open Shortest Path First (OSPF) protocol is created in the **no shutdown** state.  
**OSPF Interface** — When an IP interface is configured as an OSPF interface, OSPF on the interface is in the **no shutdown** state by default.

---

## OSPF Global Commands

### ospf

**Syntax** [no] **ospf** *ospf-instance*

**Context** config>router

**Description** This command configures the router ID for the OSPF instance OSPF. The router ID configured in the base instance of OSPF overrides the router ID configured in the **config>router** context. The default value for the base instance is inherited from the configuration in the config>router context. When that is not configured the following applies:

1. The system uses the system interface address (which is also the loopback address).
2. If a system interface address is not configured, use the last 32 bits of the chassis MAC address.

This is a required command when configuring multiple instances and the instance being configured is not the base instance. When configuring multiple instances of OSPF there is a risk of loops because networks are advertised by multiple domains configured with multiple interconnections to one another. To avoid this from happening all routers in a domain should be configured with the same domain-id. Each domain (OSPF-instance) should be assigned a specific bit value in the 32-bit tag mask.

The default value for non-base instances is 0.0.0.0 and is invalid, in this case the instance of OSPF will not start. When configuring a new router ID, the instance is not automatically restarted with the new router ID. The next time the instance is initialized, the new router ID is used.

Issue the shutdown and no shutdown commands for the instance for the new router ID to be used, or reboot the entire router.

The **no** form of the command to reverts to the default value.

**Default** no ospf

**Parameters** *ospf-instance* — Specifies a unique integer that identifies a specific instance of a version of the OSPF protocol running in the router instance specified by the router ID.

**Values** 1 — 31

### ospf3

**Syntax** [no] **ospf3**

**Context** config>router

**Description** This command enables the context to configure OSPF to support version 6 of the Internet Protocol (IPv6). When an OSPF instance is created, the protocol is enabled. To start or suspend execution of the OSPF protocol without affecting the configuration, use the **no shutdown** command.

The **no** form of the command deletes the OSPF protocol instance removing all associated configuration parameters.

**Default** **no ospf** — The OSPF protocol is not enabled.

## asbr

**Syntax** **[no] asbr [trace-path domain-id]**

**Context** config>router>ospf  
config>router>ospf3

**Description** This command configures the router as a Autonomous System Boundary Router (ASBR) if the router is to be used to export routes from the Routing Table Manager (RTM) into this instance of OSPF. Once a router is configured as an ASBR, the export policies into this OSPF domain take effect. If no policies are configured no external routes are redistributed into the OSPF domain.

The **no** form of the command removes the ASBR status and withdraws the routes redistributed from the Routing Table Manager into this instance of OSPF from the link state database.

When configuring multiple instances of OSPF there is a risk of loops because networks are advertised by multiple domains configured with multiple interconnections to one another. To avoid this from happening all routers in a domain should be configured with the same domain-id. Each domain (OSPF-instance) should be assigned a specific bit value in the 32-bit tag mask.

When an external route is originated by an ASBR using an internal OSPF route in a given domain, the corresponding bit is set in the AS-external LSA. As the route gets redistributed from one domain to another, more bits are set in the tag mask, each corresponding to the OSPF domain the route visited. Route redistribution looping is prevented by checking the corresponding bit as part of the export policy; if the bit corresponding to the announcing OSPF process is already set, the route is not exported there

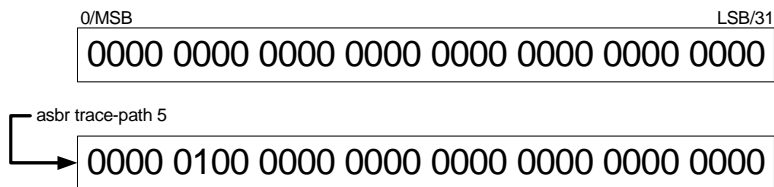

Domain-IDs are incompatible with any other use of normal tags. The domain ID should be configured with a value between 1 and 31 by each router in a given OSPF domain (OSPF Instance).

When an external route is originated by an ASBR using an internal OSPF route in a given domain, the corresponding (1-31) bit is set in the AS-external LSA.

As the route gets redistributed from one domain to another, more bits are set in the tag mask, each corresponding to the OSPF domain the route visited. Route redistribution looping is prevented by checking the corresponding bit as part of the export policy; if the bit corresponding to the announcing OSPF process is already set, the route is not exported there.

**Default** **no asbr** — The router is not an ASBR.

## OSPF Global Commands

**Parameters** *domain-id* — Specifies the domain ID.

**Values** 1 — 31

**Default** 0

### compatible-rfc1583

**Syntax** **[no] compatible-rfc1583**

**Context** config>router>ospf

**Description** This command enables OSPF summary and external route calculations in compliance with RFC1583 and earlier RFCs.

RFC1583 and earlier RFCs use a different method to calculate summary and external route costs. To avoid routing loops, all routers in an OSPF domain should perform the same calculation method.

Although it would be favorable to require all routers to run a more current compliancy level, this command allows the router to use obsolete methods of calculation.

The **no** form of the command enables the post-RFC1583 method of summary and external route calculation.

**Default** **compatible-rfc1583** — RFC1583 compliance is enabled.

### disable-ldp-sync

**Syntax** **[no] disable-ldp-sync**

**Context** config>router>ospf

**Description** This command disables the IGP-LDP synchronization feature on all interfaces participating in the OSPF routing protocol. When this command is executed, IGP immediately advertises the actual value of the link cost for all interfaces which have the IGP-LDP synchronization enabled if the currently advertized cost is different. It will then disable IGP-LDP synchronizaton for all interfaces. This command does not delete the interface configuration. The **no** form of this command has to be entered to re-enable IGP-LDP synchronization for this routing protocol.

The **no** form of this command restores the default settings and re-enables IGP-LDP synchronization on all interfaces participating in the OSPF or IS-IS routing protocol and for which the ldp-sync-timer is configured.

**Default** **no disable-ldp-sync**

## export

- Syntax** **export** *policy-name* [*policy-name...*]  
**no export**
- Context** config>router>ospf  
config>router>ospf3
- Description** This command associates export route policies to determine which routes are exported from the route table to OSPF. Export polices are only in effect if OSPF is configured as an ASBR.
- If no export policy is specified, non-OSPF routes are not exported from the routing table manager to OSPF.
- If multiple policy names are specified, the policies are evaluated in the order they are specified. The first policy that matches is applied. If multiple export commands are issued, the last command entered will override the previous command. A maximum of five policy names can be specified.
- The **no** form of the command removes all policies from the configuration.
- Default** **no export** — No export route policies specified.
- Parameters** *policy-name* — The export route policy name. Allowed values are any string up to 32 characters long composed of printable, 7-bit ASCII characters. If the string contains special characters (#, \$, spaces, etc.), the entire string must be enclosed within double quotes.
- The specified name(s) must already be defined.

## export-limit

- Syntax** **export-limit** *number* [**log** *percentage*]  
**no export-limit**
- Context** config>router>ospf  
config>router>ospf3
- Description** This command configures the maximum number of routes (prefixes) that can be exported into OSPF from the route table.
- The **no** form of the command removes the parameters from the configuration.
- Default** no export-limit, the export limit for routes or prefixes is disabled..
- Parameters** *number* — Specifies the maximum number of routes (prefixes) that can be exported into OSPF from the route table.
- Values** 1 — 4294967295
- log percentage** — Specifies the percentage of the export-limit, at which a warning log message and SNMP notification would be sent.
- Values** 1 — 100

### external-db-overflow

|                    |                                                                                                                                                                                                                                                                                                                                                                                                                                                                                                                                                                                                                                                                                                                                                                                                                                                                                                                                                                                                                                                                                                                                                                                                                                                                                                                                                                                                                                                                                |
|--------------------|--------------------------------------------------------------------------------------------------------------------------------------------------------------------------------------------------------------------------------------------------------------------------------------------------------------------------------------------------------------------------------------------------------------------------------------------------------------------------------------------------------------------------------------------------------------------------------------------------------------------------------------------------------------------------------------------------------------------------------------------------------------------------------------------------------------------------------------------------------------------------------------------------------------------------------------------------------------------------------------------------------------------------------------------------------------------------------------------------------------------------------------------------------------------------------------------------------------------------------------------------------------------------------------------------------------------------------------------------------------------------------------------------------------------------------------------------------------------------------|
| <b>Syntax</b>      | <b>external-db-overflow</b> <i>limit interval</i><br><b>no external-db-overflow</b>                                                                                                                                                                                                                                                                                                                                                                                                                                                                                                                                                                                                                                                                                                                                                                                                                                                                                                                                                                                                                                                                                                                                                                                                                                                                                                                                                                                            |
| <b>Context</b>     | config>router>ospf<br>config>router>ospf3                                                                                                                                                                                                                                                                                                                                                                                                                                                                                                                                                                                                                                                                                                                                                                                                                                                                                                                                                                                                                                                                                                                                                                                                                                                                                                                                                                                                                                      |
| <b>Description</b> | <p>This command enables limits on the number of non-default AS-external-LSA entries that can be stored in the LSDB and specifies a wait timer before processing these after the limit is exceeded.</p> <p>The <i>limit</i> value specifies the maximum number of non-default AS-external-LSA entries that can be stored in the link-state database (LSDB). Placing a limit on the non-default AS-external-LSAs in the LSDB protects the router from receiving an excessive number of external routes that consume excessive memory or CPU resources. If the number of routes reach or exceed the <i>limit</i>, the table is in an overflow state. When in an overflow state, the router will not originate any new AS-external-LSAs. In fact, it withdraws all the self-originated non-default external LSAs.</p> <p>The <i>interval</i> specifies the amount of time to wait after an overflow state before regenerating and processing non-default AS-external-LSAs. The waiting period acts like a dampening period preventing the router from continuously running Shortest Path First (SPF) calculations caused by the excessive number of non-default AS-external LSAs.</p> <p>The <b>external-db-overflow</b> must be set identically on all routers attached to any regular OSPF area. OSPF stub areas and not-so-stubby areas (NSSAs) are excluded.</p> <p>The <b>no</b> form of the command disables limiting the number of non-default AS-external-LSA entries.</p> |
| <b>Default</b>     | <b>no external-db-overflow</b> — No limit on non-default AS-external-LSA entries.                                                                                                                                                                                                                                                                                                                                                                                                                                                                                                                                                                                                                                                                                                                                                                                                                                                                                                                                                                                                                                                                                                                                                                                                                                                                                                                                                                                              |
| <b>Parameters</b>  | <p><i>limit</i> — The maximum number of non-default AS-external-LSA entries that can be stored in the LSDB before going into an overflow state expressed as a decimal integer.</p> <p><b>Values</b> 0 — 2147483674</p> <p><i>interval</i> — The number of seconds after entering an overflow state before attempting to process non-default AS-external-LSAs expressed as a decimal integer.</p> <p><b>Values</b> 0 — 2147483674</p>                                                                                                                                                                                                                                                                                                                                                                                                                                                                                                                                                                                                                                                                                                                                                                                                                                                                                                                                                                                                                                           |

### external-preference

|                    |                                                                                                                                                                                                                                                                        |
|--------------------|------------------------------------------------------------------------------------------------------------------------------------------------------------------------------------------------------------------------------------------------------------------------|
| <b>Syntax</b>      | <b>external-preference</b> <i>preference</i><br><b>no external-preference</b>                                                                                                                                                                                          |
| <b>Context</b>     | config>router>ospf<br>config>router>ospf3                                                                                                                                                                                                                              |
| <b>Description</b> | <p>This command configures the preference for OSPF external routes.</p> <p>A route can be learned by the router from different protocols, in which case, the costs are not comparable. When this occurs the preference is used to decide which route will be used.</p> |

Different protocols should not be configured with the same preference, if this occurs the tiebreaker is per the default preference table as defined in the Table 10, “Route Preference Defaults by Route Type,” on page 359. If multiple routes are learned with an identical preference using the same protocol, the lowest cost route is used.

If multiple routes are learned with an identical preference using the same protocol and the costs (metrics) are equal, then the decision of what route to use is determined by the configuration of the **ecmp** in the `config>router` context.

The **no** form of the command reverts to the default value.

**Default** **external-preference 150** — OSPF external routes have a default preference of 150.

**Parameters** *preference* — The preference for external routes expressed as a decimal integer. Defaults for different route types are listed in Table 10.

**Table 10: Route Preference Defaults by Route Type**

| Route Type             | Preference | Configurable |
|------------------------|------------|--------------|
| Direct attached        | 0          | No           |
| Static routes          | 5          | Yes          |
| OSPF internal          | 10         | Yes*         |
| IS-IS level 1 internal | 15         | Yes          |
| IS-IS level 2 internal | 18         | Yes          |
| RIP                    | 100        | Yes          |
| OSPF external          | 150        | Yes          |
| IS-IS level 1 external | 160        | Yes          |
| IS-IS level 2 external | 165        | Yes          |
| BGP                    | 170        | Yes          |

\*. Preference for OSPF internal routes is configured with the **preference** command.

**Values** 1 — 255

## graceful-restart

**Syntax** **[no] graceful-restart**

**Context** `config>router>ospf`  
`config>router>ospf3`

**Description** This command enables graceful-restart for OSPF. When the control plane of a GR-capable router fails, the neighboring routers (GR helpers) temporarily preserve adjacency information, so packets continue to be forwarded through the failed GR router using the last known routes. If the control plane of the GR router

## OSPF Global Commands

comes back up within the GR timer, then the routing protocols would re-converge to minimize service interruption.

The **no** form of the command disables graceful restart and removes all graceful restart configurations in the OSPF instance.

**Default** **no graceful-restart**

## helper-disable

**Syntax** **[no] helper-disable**

**Context** config>router>ospf>graceful-restart  
config>router>ospf3>graceful-restart

**Description** This command disables the helper support for graceful restart.

When **graceful-restart** is enabled, the router can be a helper (meaning that the router is helping a neighbor to restart) or be a restarting router or both. The 7750 SR OS supports only helper mode. This facilitates the graceful restart of neighbors but will not act as a restarting router (meaning that the 7750 SR OS will not help the neighbors to restart).

The **no helper-disable** command enables helper support and is the default when graceful-restart is enabled.

**Default** **disabled**

## import

**Syntax** **import** *policy-name* [*policy-name...*(upto 5 max)]  
**no import**

**Context** config>router>ospf  
config>router>ospf3

**Description** This command applies one or more (up to 5) route policies as OSPF import policies. When a prefix received in an OSPF LSA is accepted by an entry in an OSPF import policy it is installed in the routing table if it is the most preferred route to the destination. When a prefix received in an OSPF LSA is rejected by an entry in an OSPF import policy it is not installed in the routing table, even if it has the lowest preference value among all the routes to that destination. The flooding of LSAs is unaffected by OSPF import policy actions.

**Default** If an OSPF route has the lowest preference value among all routes to a destination it is installed in the routing table.



## ldp-over-rsvp

**Syntax** [no] ldp-over-rsvp

**Context** config>router>ospf

**Description** This command allows LDP-over-RSVP processing in this OSPF instance.

## loopfree-alternate

**Syntax** [no] loopfree-alternate

**Context** config>router>ospf  
config>router>ospf3

**Description** This command enables Loop-Free Alternate (LFA) computation by SPF under the IS-IS routing protocol level or under the OSPF routing protocol instance level.

When this command is enabled, it instructs the IGP SPF to attempt to pre-compute both a primary next-hop and an LFA next-hop for every learned prefix. When found, the LFA next-hop is populated into the routing table along with the primary next-hop for the prefix.

The **no** form of this command disables the LFA computation by IGP SPF.

**Default** no loopfree-alternate

## mcast-import-ipv6

**Syntax** [no] mcast-import-ipv6

**Context** configure>router>ospf3

**Description** This command administratively enables the submission of routes into the IPv6 multicast RTM by OSPF3. The no form of the command disables the submission of the routes.

## multicast-import

**Syntax** [no] multicast-import

**Context** config>router>ospf

**Description** This command enables the submission of routes into the multicast Route Table Manager (RTM) by OSPF. The **no** form of the command disables the submission of routes into the multicast RTM.

**Default** no multicast-import

## OSPF Global Commands

### overload

**Syntax** **overload** [timeout *seconds*]  
**no overload**

**Context** config>router>ospf  
config>router>ospf3

**Description** This command changes the overload state of the local router so that it appears to be overloaded. When overload is enabled, the router can participate in OSPF routing, but is not used for transit traffic. Traffic destined to directly attached interfaces continues to reach the router.

To put the IGP in an overload state enter a timeout value. The IGP will enter the overload state until the timeout timer expires or a **no overload** command is executed.

If the **overload** command is encountered during the execution of an **overload-on-boot** command then this command takes precedence. This could occur as a result of a saved configuration file where both parameters are saved. When the file is saved by the system the **overload-on-boot** command is saved after the **overload** command. **However**, when **overload-on-boot** is configured under OSPF with no timeout value configured, the router will remain in overload state indefinitely after a reboot.

Use the **no** form of this command to return to the default. When the **no overload** command is executed, the overload state is terminated regardless of the reason the protocol entered overload state.

**Default** **no overload**

**Parameters** **timeout** *seconds* — Specifies the number of seconds to reset overloading.

**Values** 1 — 1800

**Default** 60

### overload-include-stub

**Syntax** [**no**] **overload-include-stub**

**Context** config>router>ospf  
config>router>ospf3

**Description** This command is used to determine if the OSPF stub networks should be advertised with a maximum metric value when the system goes into overload state for any reason. When enabled, the system uses the maximum metric value. When this command is enabled and the router is in overload, all stub interfaces, including loopback and system interfaces, will be advertised at the maximum metric.

**Default** **no overload-include-stub**

## overload-on-boot

|                    |                                                                                                                                                                                                                                                                                                                                                                                                                                                                                                                                                                                                                                                                                                                                                                                                                                                                                                                                                       |
|--------------------|-------------------------------------------------------------------------------------------------------------------------------------------------------------------------------------------------------------------------------------------------------------------------------------------------------------------------------------------------------------------------------------------------------------------------------------------------------------------------------------------------------------------------------------------------------------------------------------------------------------------------------------------------------------------------------------------------------------------------------------------------------------------------------------------------------------------------------------------------------------------------------------------------------------------------------------------------------|
| <b>Syntax</b>      | <b>overload-on-boot</b> [ <i>timeout seconds</i> ]<br><b>no overload</b>                                                                                                                                                                                                                                                                                                                                                                                                                                                                                                                                                                                                                                                                                                                                                                                                                                                                              |
| <b>Context</b>     | config>router>ospf<br>config>router>ospf3                                                                                                                                                                                                                                                                                                                                                                                                                                                                                                                                                                                                                                                                                                                                                                                                                                                                                                             |
| <b>Description</b> | <p>When the router is in an overload state, the router is used only if there is no other router to reach the destination. This command configures the IGP upon bootup in the overload state until one of the following events occur:</p> <ul style="list-style-type: none"> <li>• The timeout timer expires.</li> <li>• A manual override of the current overload state is entered with the <b>no overload</b> command.</li> </ul> <p>The <b>no overload</b> command does not affect the <b>overload-on-boot</b> function.</p> <p>The <b>no</b> form of the command removes the overload-on-boot functionality from the configuration.</p> <p>The default timeout value is 60 seconds, which means after 60 seconds overload status the SR will recover (change back to non-overload status). However, when overload-on-boot is configured under OSPF with no timeout value the router will remain in overload state indefinitely after a reboot.</p> |
| <b>Parameters</b>  | <p><b>timeout</b> <i>seconds</i> — Specifies the number of seconds to reset overloading.</p> <p><b>Values</b>      1 — 1800</p> <p><b>Default</b>      indefinitely in overload.</p>                                                                                                                                                                                                                                                                                                                                                                                                                                                                                                                                                                                                                                                                                                                                                                  |

## preference

|                |                                                                                                                                                                                                                                                                                                                                                                                                                                                                                                                                                                                                                                                                                                                                                                                                                                                                                                                       |
|----------------|-----------------------------------------------------------------------------------------------------------------------------------------------------------------------------------------------------------------------------------------------------------------------------------------------------------------------------------------------------------------------------------------------------------------------------------------------------------------------------------------------------------------------------------------------------------------------------------------------------------------------------------------------------------------------------------------------------------------------------------------------------------------------------------------------------------------------------------------------------------------------------------------------------------------------|
| <b>Syntax</b>  | <b>preference</b> <i>preference</i><br><b>no preference</b>                                                                                                                                                                                                                                                                                                                                                                                                                                                                                                                                                                                                                                                                                                                                                                                                                                                           |
| <b>Context</b> | config>router>ospf<br>config>router>ospf3                                                                                                                                                                                                                                                                                                                                                                                                                                                                                                                                                                                                                                                                                                                                                                                                                                                                             |
|                | <p>This command configures the preference for OSPF internal routes.</p> <p>A route can be learned by the router from different protocols, in which case, the costs are not comparable. When this occurs the preference is used to decide which route will be used.</p> <p>Different protocols should not be configured with the same preference, if this occurs the tiebreaker is per the default preference table as defined in <a href="#">Table 11</a>. If multiple routes are learned with an identical preference using the same protocol, the lowest cost route is used.</p> <p>If multiple routes are learned with an identical preference using the same protocol and the costs (metrics) are equal, then the decision of what route to use is determined by the configuration of the <b>ecmp</b> in the config&gt;router context.</p> <p>The <b>no</b> form of the command reverts to the default value.</p> |
| <b>Default</b> | <b>preference 10</b> — OSPF internal routes have a preference of 10.                                                                                                                                                                                                                                                                                                                                                                                                                                                                                                                                                                                                                                                                                                                                                                                                                                                  |

## OSPF Global Commands

**Parameters** *preference* — The preference for internal routes expressed as a decimal integer. Defaults for different route types are listed in Table 11.

**Table 11: Route Preference Defaults by Route Type**

| Route Type             | Preference | Configurable |
|------------------------|------------|--------------|
| Direct attached        | 0          | No           |
| Static routes          | 5          | Yes          |
| OSPF internal          | 10         | Yes*         |
| IS-IS level 1 internal | 15         | Yes          |
| IS-IS level 2 internal | 18         | Yes          |
| RIP                    | 100        | Yes          |
| OSPF external          | 150        | Yes          |
| IS-IS level 1 external | 160        | Yes          |
| IS-IS level 2 external | 165        | Yes          |
| BGP                    | 170        | Yes          |

\*. Preference for OSPF internal routes is configured with the **preference** command.

**Values** 1 — 255

## reference-bandwidth

**Syntax** **reference-bandwidth** *bandwidth-in-kbps*  
**no reference-bandwidth**

**Context** config>router>ospf  
config>router>ospf3

**Description** This command configures the reference bandwidth in kilobits per second (Kbps) that provides the reference for the default costing of interfaces based on their underlying link speed.

The default interface cost is calculated as follows:

$$\text{cost} = \text{reference-bandwidth} \div \text{bandwidth}$$

The default *reference-bandwidth* is 100,000,000 Kbps or 100 Gbps, so the default auto-cost metrics for various link speeds are as follows:

- 10 Mbs link default cost of 10000
- 100 Mbs link default cost of 1000
- 1 Gbps link default cost of 100

- 10 Gbps link default cost of 10

The **reference-bandwidth** command assigns a default cost to the interface based on the interface speed. To override this default cost on a particular interface, use the **metric** *metric* command in the `config>router>ospf>area>interface ip-int-name` context.

The **no** form of the command reverts the reference-bandwidth to the default value.

**Default** **reference-bandwidth 100000000** — Reference bandwidth of 100 Gbps.

**Parameters** *bandwidth-in-kbps* — The reference bandwidth in kilobits per second expressed as a decimal integer.

**Values** 1 — 1000000000

## router-id

**Syntax** **router-id ip-address**  
**no router-id**

**Context** `config>router>ospf`  
`config>router>ospf3`

**Description** This command configures the router ID for the OSPF instance. This command configures the router ID for the OSPF instance.

When configuring the router ID in the base instance of OSPF it overrides the router ID configured in the **config>router** context.

The default value for the base instance is inherited from the configuration in the **config>router** context. If the router ID in the **tconfig>router** context is not configured, the following applies:

- The system uses the system interface address (which is also the loopback address).
- If a system interface address is not configured, use the last 32 bits of the chassis MAC address.

This is a **required** command when configuring multiple instances and the instance being configured is not the base instance.

When configuring a new router ID, the instance is not automatically restarted with the new router ID. The next time the instance is initialized, the new router ID is used.

To force the new router ID to be used, issue the **shutdown** and **no shutdown** commands for the instance, or reboot the entire router.

The **no** form of the command reverts to the default value.

**Default** The default value for non-base instances is 0.0.0.0 and is invalid, in this case the instance of OSPF will not start and when doing a show command an error condition will be displayed.

**Parameters** *ip-address* — Specifies a 32-bit, unsigned integer uniquely identifying the router in the Autonomous System.

### rsvp-shortcut

**Syntax** [no] **rsvp-shortcut**

**Context** config>router>ospf

**Description** This command enables the use of an RSVP-TE shortcut for resolving IGP routes by IS-IS or OSPF routing protocols.

This command instructs IS-IS or OSPF to include RSVP LSPs originating on this node and terminating on the router-id of a remote node as direct links with a metric equal to the operational metric provided by MPLS.

When **rsvp-shortcut** is enabled at the IGP instance level, all RSVP LSPs originating on this node are eligible by default as long as the destination address of the LSP, as configured in **config-ure>router>mpls>lsp>to**, corresponds to a router-id of a remote node. RSVP LSPs with a destination address corresponding to an interface address of a remote node are automatically not considered by IS-IS or OSPF. The user can however exclude a specific RSVP LSP from being used as a shortcut for resolving IGP routes by entering the command **config>router>mpls>lsp>no igp-shortcut**.

Also, the SPF in OSPF or IS-IS will only use RSVP LSPs as IGP shortcuts or as endpoints for LDP-over-RSVP. These applications of RSVP LSPs are mutually exclusive at the IGP instance level. If the user enabled both options at the IGP instance level, then the shortcut application takes precedence when the LSP level configuration has both options enabled.

When an IPv4 packet is received on an ingress network interface, a subscriber IES interface, or a regular IES interface, the lookup of the packet in RTM will result in the resolution of the packet to an RSVP LSP if all the following conditions are satisfied:

- RSVP shortcut is enabled on the IGP routing protocol which has a route for the packet's destination address.
- SPF has pre-determined that the IGP path cost using the RSVP LSP shortcut is the best.

In this case, the packet is sent labeled with the label stack corresponding to the NHLFE of the RSVP LSP.

The failure of an RSVP LSP shortcut or of a local interface triggers a full SPF computation which may result in installing a new route over another RSVP LSP shortcut or a regular IP next-hop.

When ECMP is enabled and multiple equal-cost paths exist for the IGP route, the ingress IOM will spray the packets for this route based on hashing routine currently supported for IPv4 packets. Spraying will be performed across a regular IP next-hop and across an RSVP shortcut next-hop as long as the IP path does not go over the tail-end of the RSVP LSP.

The no form of this command disables the resolution of IGP routes using RSVP shortcuts.

**Default** no **rsvp-shortcut**

## advertise-tunnel-links

**Syntax** [no] advertise-tunnel-links

**Context** config>router>ospf

**Description** This command enables the advertisement of RSVP LSP shortcuts into IGP similar to regular links so that other routers in the network can include them in their SPF computations. An LSP must exist in the reverse direction in order for the advertized link to pass the bi-directional link check and be usable by other routers in the network. However, this is not required for the node which originates the LSP.

The LSP is advertised as an unnumbered point-to-point link and the link LSP/LSA has no Traffic Engineering opaque sub-TLVs per RFC 3906.

The **no** form of this command disables the advertisement of RSVP LSP shortcuts into IGP.

**Default** no advertise-tunnel-links

## super-backbone

**Syntax** [no] super-backbone

**Context** config>service>vprn>ospf

**Description** This command specifies whether CE-PE functionality is required or not. The OSPF super backbone indicates the type of the LSA generated as a result of routes redistributed into OSPF. When enabled, the redistributed routes are injected as summary, external or NSSA LSAs. When disabled, the redistributed routes are injected as either external or NSSA LSAs only.

Refer to the OS Services Guide for syntax and command usage information.

The **no** form of the command disables the the super-backbone functionality.

**Default** no super-backbone

## timers

**Syntax** timers

**Context** config>router>ospf  
config>router>ospf3

**Description** This command enables the context that allows for the configuration of OSPF timers. Timers control the delay between receipt of a link state advertisement (LSA) requiring a Dijkstra (Shortest Path First (SPF)) calculation and the minimum time between successive SPF calculations.

Changing the timers affects CPU utilization and network reconvergence times. Lower values reduce convergence time but increase CPU utilization. Higher values reduce CPU utilization but increase reconvergence time.

**Default** none

### lsa-arrival

|                    |                                                                                                                                                                                                                                                                                                                                                                                                                  |
|--------------------|------------------------------------------------------------------------------------------------------------------------------------------------------------------------------------------------------------------------------------------------------------------------------------------------------------------------------------------------------------------------------------------------------------------|
| <b>Syntax</b>      | <b>lsa-arrival</b> <i>lsa-arrival-time</i><br><b>no lsa-arrival</b>                                                                                                                                                                                                                                                                                                                                              |
| <b>Context</b>     | config>router>ospf>timers<br>config>router>ospf3                                                                                                                                                                                                                                                                                                                                                                 |
| <b>Description</b> | <p>This parameter defines the minimum delay that must pass between receipt of the same Link State Advertisements (LSAs) arriving from neighbors.</p> <p>It is recommended that the neighbors configured (<b>lsa-generate</b>) <i>lsa-second-wait</i> interval is equal or greater than the <b>lsa-arrival</b> timer configured here.</p> <p>Use the <b>no</b> form of this command to return to the default.</p> |
| <b>Default</b>     | <b>no lsa-arrival</b>                                                                                                                                                                                                                                                                                                                                                                                            |
| <b>Parameters</b>  | <i>lsa-arrival-time</i> — Specifies the timer in milliseconds. Values entered that do not match this requirement will be rejected.                                                                                                                                                                                                                                                                               |
|                    | <b>Values</b> 0 — 600000                                                                                                                                                                                                                                                                                                                                                                                         |

### lsa-generate

|                    |                                                                                                                                                                                                                                                                                                                                                                                                                                                                                                                                                                           |
|--------------------|---------------------------------------------------------------------------------------------------------------------------------------------------------------------------------------------------------------------------------------------------------------------------------------------------------------------------------------------------------------------------------------------------------------------------------------------------------------------------------------------------------------------------------------------------------------------------|
| <b>Syntax</b>      | <b>lsa-generate</b> <i>max-lsa-wait</i> [ <i>lsa-initial-wait</i> [ <i>lsa-second-wait</i> ]]<br><b>no lsa-generate-interval</b>                                                                                                                                                                                                                                                                                                                                                                                                                                          |
| <b>Context</b>     | config>router>ospf>timers<br>config>router>ospf3                                                                                                                                                                                                                                                                                                                                                                                                                                                                                                                          |
| <b>Description</b> | <p>This parameter customizes the throttling of OSPF LSA-generation. Timers that determine when to generate the first, second, and subsequent LSAs can be controlled with this command. Subsequent LSAs are generated at increasing intervals of the <i>lsa-second-wait</i> timer until a maximum value is reached.</p> <p>Configuring the <b>lsa-arrival</b> interval to equal or less than the <i>lsa-second-wait</i> interval configured in the <b>lsa-generate</b> command is recommended.</p> <p>Use the <b>no</b> form of this command to return to the default.</p> |
| <b>Default</b>     | <b>no lsa-generate</b>                                                                                                                                                                                                                                                                                                                                                                                                                                                                                                                                                    |
| <b>Parameters</b>  | <i>max-lsa-wait</i> — Specifies the maximum interval, in milliseconds, between two consecutive occurrences of an LSA being generated.                                                                                                                                                                                                                                                                                                                                                                                                                                     |
|                    | <b>Values</b> 10 — 600,000                                                                                                                                                                                                                                                                                                                                                                                                                                                                                                                                                |
|                    | <b>Default</b> 5,000 milliseconds                                                                                                                                                                                                                                                                                                                                                                                                                                                                                                                                         |
|                    | <i>lsa-initial-wait</i> — Specifies the first waiting period between link-state advertisements (LSA) originate(s), in milliseconds. When the LSA exceeds the <i>lsa-initial-wait</i> timer value and the topology changes, there is no wait period and the LSA is immediately generated.                                                                                                                                                                                                                                                                                  |



When an LSA is generated, the initial wait period commences. If, within the specified *lsa-initial-wait* period and another topology change occurs, then the *lsa-initial-wait* timer applies.

**Values** 10 — 600000

**Default** 5,000 milliseconds

*lsa-second-wait* — Specifies the hold time in milliseconds between the first and second LSA generation. The next topology change is subject to this second wait period. With each subsequent topology change, the wait time doubles (this is 2x the previous wait time.). This assumes that each failure occurs within the relevant wait period.

**Values** 10 — 600000

**Default** 5,000 milliseconds

## spf-wait

**Syntax** **spf-wait** *max-spf-wait* [*spf-initial-wait* [*spf-second-wait*]]  
**no spf-wait**

**Context** config>router>ospf>timers  
config>router>ospf3

**Description** This command defines the maximum interval between two consecutive SPF calculations in milliseconds. Timers that determine when to initiate the first, second, and subsequent SPF calculations after a topology change occurs can be controlled with this command. Subsequent SPF runs (if required) will occur at exponentially increasing intervals of the *spf-second-wait* interval. For example, if the *spf-second-wait* interval is 1000, then the next SPF will run after 2000 milliseconds, and then next SPF will run after 4000 milliseconds, etc., until it reaches the **spf-wait** value. The SPF interval will stay at the **spf-wait** value until there are no more SPF runs scheduled in that interval. After a full interval without any SPF runs, the SPF interval will drop back to *spf-initial-wait*.

The timer must be entered in increments of 100 milliseconds. Values entered that do not match this requirement will be rejected.

Use the **no** form of this command to return to the default.

**Default** **no spf-wait**

**Parameters** *max-spf-wait* — Specifies the maximum interval in milliseconds between two consecutive SPF calculations.

**Values** 10 — 120000

**Default** 1000

*spf-initial-wait* — Specifies the initial SPF calculation delay in milliseconds after a topology change.

**Values** 10 — 100000

**Default** 1000

## OSPF Global Commands

*spf-second-wait* — Specifies the hold time in milliseconds between the first and second SPF calculation.

**Values** 10 — 100000

**Default** 1000

### traffic-engineering

**Syntax** [no] **traffic-engineering**

**Context** config>router>ospf

**Description** This command enables traffic engineering route calculations constrained by nodes or links. Traffic engineering enables the router to perform route calculations constrained by nodes or links. The traffic engineering capabilities of this router are limited to calculations based on link and nodal constraints. The **no** form of the command disables traffic engineered route calculations.

**Default** **no traffic-engineering** — Traffic engineered route calculations is disabled.

### unicast-import-disable

**Syntax** [no] **unicast-import-disable**

**Context** config>router>ospf

**Description** This command allows one IGP to import its routes into RPF RTM while another IGP imports routes only into the unicast RTM. Import policies can redistribute routes from an IGP protocol into the RPF RTM (the multicast routing table). By default, the IGP routes will not be imported into RPF RTM as such an import policy must be explicitly configured.

**Default** **disabled**

---

## OSPF Area Commands

### area

**Syntax** [no] area *area-id*

**Context** config>router>ospf  
config>router>ospf3

**Description** This command creates the context to configure an OSPF or OSPF3 area. An area is a collection of network segments within an AS that have been administratively grouped together. The area ID can be specified in dotted decimal notation or as a 32-bit decimal integer.

The **no** form of the command deletes the specified area from the configuration. Deleting the area also removes the OSPF configuration of all the interfaces, virtual-links, and address-ranges etc., that are currently assigned to this area.

**Default** no area — No OSPF areas are defined.

**Parameters** *area-id* — The OSPF area ID expressed in dotted decimal notation or as a 32-bit decimal integer.

**Values** 0.0.0.0 — 255.255.255.255 (dotted decimal), 0 — 4294967295 (decimal integer)

### area-range

**Syntax** area-range *ip-prefix/mask* [advertise | not-advertise]  
no area-range *ip-prefix/mask*

**Context** config>router>ospf>area  
config>router>ospf>area>nssa

**Description** This command creates ranges of addresses on an Area Border Router (ABR) for the purpose of route summarization or suppression. When a range is created, the range is configured to be advertised or not advertised into other areas. Multiple range commands may be used to summarize or hide different ranges. In the case of overlapping ranges, the most specific range command applies.

ABRs send summary link advertisements to describe routes to other areas. To minimize the number of advertisements that are flooded, you can summarize a range of IP addresses and send reachability information about these addresses in an LSA.

The **no** form of the command deletes the range (non) advertisement.

**Default** no area-range — No range of addresses are defined.

**Special Cases** **NSSA Context** — In the NSSA context, the option specifies that the range applies to external routes (via type-7 LSAs) learned within the NSSA when the routes are advertised to other areas as type-5 LSAs.

**Area Context** — If this command is not entered under the NSSA context, the range applies to summary LSAs even if the area is an NSSA.

## OSPF Area Commands

- Parameters** *ip-prefix* — The IP prefix in dotted decimal notation for the range used by the ABR to advertise that summarizes the area into another area.
- Values** ip-prefix/mask: ip-prefix a.b.c.d (host bits must be 0)
- mask* — The subnet mask for the range expressed as a decimal integer mask length or in dotted decimal notation.
- Values** 0 — 32 (mask length), 0.0.0.0 — 255.255.255.255 (dotted decimal)
- advertise** | **not-advertise** — Specifies whether or not to advertise the summarized range of addresses into other areas. The **advertise** keyword indicates the range will be advertised, and the keyword **not-advertise** indicates the range will not be advertised. The default is **advertise**.

### area-range

- Syntax** **area-range** *ipv6-prefix/prefix-length* [**advertise** | **not-advertise**]  
**no area-range** *ip-prefix/prefix-length*
- Context** config>router>ospf3>area  
config>router>ospf3>area>nssa
- Description** This command creates ranges of addresses on an Area Border Router (ABR) for the purpose of route summarization or suppression. When a range is created, the range is configured to be advertised or not advertised into other areas. Multiple range commands may be used to summarize or hide different ranges. In the case of overlapping ranges, the most specific range command applies.
- ABRs send summary link advertisements to describe routes to other areas. To minimize the number of advertisements that are flooded, you can summarize a range of IP addresses and send reachability information about these addresses in an LSA.
- The **no** form of the command deletes the range (non) advertisement.
- Default** **no area-range** — No range of addresses are defined.
- Special Cases** **NSSA Context** — In the NSSA context, the option specifies that the range applies to external routes (via type-7 LSAs) learned within the NSSA when the routes are advertised to other areas as type-5 LSAs.
- Area Context** — If this command is not entered under the NSSA context, the range applies to summary LSAs even if the area is an NSSA.
- Parameters** *ip-prefix/prefix-length* — The IP prefix in dotted decimal notation for the range used by the ABR to advertise that summarizes the area into another area.
- Values** ip-prefix/mask: ip-prefix a.b.c.d (host bits must be 0)  
ipv6-prefix: x:x:x:x:x:x:x (eight 16-bit pieces)  
x:x:x:x:x:d.d.d.d  
x: [0 — FFFF]H  
d: [0 — 255]D  
prefix-length: 0 — 128
- advertise** | **not-advertise** — Specifies whether or not to advertise the summarized range of addresses into other areas. The **advertise** keyword indicates the range will be advertised, and the keyword **not-**

**advertise** indicates the range will not be advertised.  
The default is **advertise**.

## blackhole-aggregate

**Syntax** **[no] blackhole-aggregate**

**Context** config>router>ospf>area  
config>router>ospf3>area

**Description** This command installs a low priority blackhole route for the entire aggregate. Existing routes that make up the aggregate will have a higher priority and only the components of the range for which no route exists are blackholed.

It is possible that when performing area aggregation, addresses may be included in the range for which no actual route exists. This can cause routing loops. To avoid this problem configure the blackhole aggregate option.

The **no** form of this command removes this option.

**Default** **blackhole-aggregate**

## default-metric

**Syntax** **default-metric** *metric*  
**no default-metric**

**Context** config>router>ospf>area>stub  
config>router>ospf3>area

**Description** This command configures the metric used by the area border router (ABR) for the default route into a stub area.

The default metric should only be configured on an ABR of a stub area.

An ABR generates a default route if the area is a **stub** area.

The **no** form of the command reverts to the default value.

**Default** **default-metric 1**

**Parameters** *metric* — The metric expressed as a decimal integer for the default route cost to be advertised into the stub area.

**Values** 1 — 16777215

### loopfree-alternate-exclude

**Syntax** [no] loopfree-alternate

**Context** config>router>ospf>area  
config>router>ospf>area>interface  
config>router>ospf3>area  
config>router>ospf3>area>interface

**Description** This command instructs IGP to not include a specific interface or all interfaces participating in a specific IS-IS level or OSPF area in the SPF LFA computation. This provides a way of reducing the LFA SPF calculation where it is not needed.

When an interface is excluded from the LFA SPF in IS-IS, it is excluded in both level 1 and level 2. When it is excluded from the LFA SPF in OSPF, it is excluded in all areas. However, the above OSPF command can only be executed under the area in which the specified interface is primary and once enabled, the interface is excluded in that area and in all other areas where the interface is secondary. If the user attempts to apply it to an area where the interface is secondary, the command will fail.

The **no** form of this command re-instates the default value for this command.

**Default** no loopfree-alternate-exclude.

### nssa

**Syntax** [no] nssa

**Context** config>router>ospf>area  
config>router>ospf3>area

**Description** This command creates the context to configure an OSPF or OSPF3 Not So Stubby Area (NSSA) and adds/removes the NSSA designation from the area.

NSSAs are similar to stub areas in that no external routes are imported into the area from other OSPF areas. The major difference between a stub area and an NSSA is an NSSA has the capability to flood external routes that it learns throughout its area and via an ABR to the entire OSPF or OSPF3 domain.

Existing virtual links of a non-stub or NSSA area will be removed when the designation is changed to NSSA or stub.

An area can be designated as stub or NSSA but never both at the same time.

By default, an area is not configured as an NSSA area.

The **no** form of the command removes the NSSA designation and configuration context from the area.

**Default** no nssa — The OSPF or OSPF3 area is not an NSSA.

## originate-default-route

**Syntax**     **originate-default-route [type-7]**  
**no originate-default-route**

**Context**     config>router>ospf>area>nssa  
config>router>ospf3>area>nssa

**Description**   This command enables the generation of a default route and its LSA type (3 or 7) into a Not So Stubby Area (NSSA) by an NSSA Area Border Router (ABR) or Autonomous System Border Router (ASBR).

When configuring an NSSA with no summaries, the ABR will inject a type 3 LSA default route into the NSSA area. Some older implementations expect a type 7 LSA default route.

The **no** form of the command disables origination of a default route.

**Default**     **no originate-default-route** — A default route is not originated.

**Parameters**   **type-7** — Specifies a type 7 LSA should be used for the default route.

Configure this parameter to inject a type-7 LSA default route instead the type 3 LSA into the NSSA configured with no summaries.

To revert to a type 3 LSA, enter **originate-default-route** without the **type-7** parameter.

**Default**     Type 3 LSA for the default route.

## redistribute-external

**Syntax**     [no] redistribute-external

**Context**     config>router>ospf>area>nssa  
config>router>ospf3>area>nssa

**Description**   This command enables the redistribution of external routes into the Not So Stubby Area (NSSA) or an NSSA area border router (ABR) that is exporting the routes into non-NSSA areas.

NSSA or Not So Stubby Areas are similar to stub areas in that no external routes are imported into the area from other OSPF or OSPF3 areas. The major difference between a stub area and an NSSA is that the NSSA has the capability to flood external routes that it learns (providing it is an ASBR) throughout its area and via an Area Border Router to the entire OSPF or OSPF3 domain.

The **no** form of the command disables the default behavior to automatically redistribute external routes into the NSSA area from the NSSA ABR.

**Default**     **redistribute-external** — External routes are redistributed into the NSSA.

## OSPF Area Commands

### stub

**Syntax** [no] stub

**Context** config>router>ospf>area  
config>router>ospf3>area

**Description** This command enables access to the context to configure an OSPF or OSPF3 stub area and adds/removes the stub designation from the area.

External routing information is not flooded into stub areas. All routers in the stub area must be configured with the **stub** command. An OSPF or OSPF3 area cannot be both an NSSA and a stub area.

Existing virtual links of a non STUB or NSSA area will be removed when its designation is changed to NSSA or STUB.

By default, an area is not a stub area.

The **no** form of the command removes the stub designation and configuration context from the area.

**Default** **no stub** — The area is not configured as a stub area.

### summaries

**Syntax** [no] summaries

**Context** config>router>ospf>area>stub  
config>router>ospf3>area>stub  
config>router>ospf>area>nssa  
config>router>ospf3>area>nssa

**Description** This command enables sending summary (type 3) advertisements into a stub area or Not So Stubby Area (NSSA) on an Area Border Router (ABR).

This parameter is particularly useful to reduce the size of the routing and Link State Database (LSDB) tables within the stub or NSSA area. (Default: summary)

By default, summary route advertisements are sent into the stub area or NSSA.

The **no** form of the command disables sending summary route advertisements and, for stub areas, only the default route is advertised by the ABR.

**Default** **summaries** — Summary routes are advertised by the ABR into the stub area or NSSA.



---

## Interface/Virtual Link Commands

### advertise-subnet

**Syntax** [no] advertise-subnet

**Context** config>router>ospf>area>interface *ip-int-name*

**Description** This command enables advertising point-to-point interfaces as subnet routes (network number and mask). When disabled, point-to-point interfaces are advertised as host routes.

The **no** form of the command disables advertising point-to-point interfaces as subnet routes meaning they are advertised as host routes.

**Default** **advertise-subnet** — Advertises point-to-point interfaces as subnet routes.

### authentication

**Syntax** **authentication** [inbound *sa-name* outbound *sa-name*]  
**authentication bidirectional** *sa-name*  
**no authentication**

**Context** config>router>ospf3>area>interface *ip-int-name*  
config>router>ospf3>area>virtual-link >*if*

**Description** This command configures the password used by the OSPF3 interface or virtual-link to send and receive OSPF3 protocol packets on the interface when simple password authentication is configured.

All neighboring routers must use the same type of authentication and password for proper protocol communication.

By default, no authentication key is configured.

The **no** form of the command removes the authentication.

**Default** **no authentication** — No authentication is defined.

**Parameters** **inbound** *sa-name* — Specifies the inbound sa-name for OSPF3 authentication.

**outbound** *sa-name* — Specifies the outbound sa-name for OSPF3 authentication.

**bidirectional** *sa-name* — Specifies bidirectional OSPF3 authentication.

### authentication-key

|                    |                                                                                                                                                                                                                                                                                                                                                                                                                                                                                                                                                                                                                                                                                                                                                                                                                                                                                                                                                                                                                                                                                                           |
|--------------------|-----------------------------------------------------------------------------------------------------------------------------------------------------------------------------------------------------------------------------------------------------------------------------------------------------------------------------------------------------------------------------------------------------------------------------------------------------------------------------------------------------------------------------------------------------------------------------------------------------------------------------------------------------------------------------------------------------------------------------------------------------------------------------------------------------------------------------------------------------------------------------------------------------------------------------------------------------------------------------------------------------------------------------------------------------------------------------------------------------------|
| <b>Syntax</b>      | <b>authentication-key</b> [ <i>authentication-key</i>   <i>hash-key</i> ] [ <b>hash</b>   <b>hash2</b> ]<br><b>no authentication-key</b>                                                                                                                                                                                                                                                                                                                                                                                                                                                                                                                                                                                                                                                                                                                                                                                                                                                                                                                                                                  |
| <b>Context</b>     | config>router>ospf>area>interface <i>ip-int-name</i><br>config>router>ospf>area>virtual-link > <i>if</i> >                                                                                                                                                                                                                                                                                                                                                                                                                                                                                                                                                                                                                                                                                                                                                                                                                                                                                                                                                                                                |
| <b>Description</b> | <p>This command configures the password used by the OSPF interface or virtual-link to send and receive OSPF protocol packets on the interface when simple password authentication is configured.</p> <p>All neighboring routers must use the same type of authentication and password for proper protocol communication. If the <b>authentication-type</b> is configured as password, then this key must be configured.</p> <p>By default, no authentication key is configured.</p> <p>The <b>no</b> form of the command removes the authentication key.</p>                                                                                                                                                                                                                                                                                                                                                                                                                                                                                                                                              |
| <b>Default</b>     | <b>no authentication-key</b> — No authentication key is defined.                                                                                                                                                                                                                                                                                                                                                                                                                                                                                                                                                                                                                                                                                                                                                                                                                                                                                                                                                                                                                                          |
| <b>Parameters</b>  | <p><i>authentication-key</i> — The authentication key. The key can be any combination of ASCII characters up to 8 characters in length (unencrypted). If spaces are used in the string, enclose the entire string in quotation marks (“ ”).</p> <p><i>hash-key</i> — The hash key. The key can be any combination of ASCII characters up to 22 characters in length (encrypted). If spaces are used in the string, enclose the entire string in quotation marks (“ ”).</p> <p>This is useful when a user must configure the parameter, but, for security purposes, the actual unencrypted key value is not provided.</p> <p><b>hash</b> — Specifies the key is entered in an encrypted form. If the <b>hash</b> parameter is not used, the key is assumed to be in a non-encrypted, clear text form. For security, all keys are stored in encrypted form in the configuration file with the <b>hash</b> parameter specified.</p> <p><b>hash2</b> — Specifies the key is entered in a more complex encrypted form. If the <b>hash2</b> parameter is not used, the less encrypted hash form is assumed.</p> |

### authentication-type

|                    |                                                                                                                                                                                                                                                                                                                                                                       |
|--------------------|-----------------------------------------------------------------------------------------------------------------------------------------------------------------------------------------------------------------------------------------------------------------------------------------------------------------------------------------------------------------------|
| <b>Syntax</b>      | <b>authentication-type</b> { <b>password</b>   <b>message-digest</b> }<br><b>no authentication-type</b>                                                                                                                                                                                                                                                               |
| <b>Context</b>     | config>router>ospf>area>interface <i>ip-int-name</i><br>config>router>ospf>area>virtual-link <i>router-id</i>                                                                                                                                                                                                                                                         |
| <b>Description</b> | <p>This command enables authentication and specifies the type of authentication to be used on the OSPF interface.</p> <p>Both simple <b>password</b> and <b>message-digest</b> authentication are supported.</p> <p>By default, authentication is not enabled on an interface.</p> <p>The <b>no</b> form of the command disables authentication on the interface.</p> |

**Default** **no authentication** — No authentication is enabled on an interface.

**Parameters** **password** — This keyword enables simple password (plain text) authentication. If authentication is enabled and no authentication type is specified in the command, simple **password** authentication is enabled.

**message-digest** — This keyword enables message digest MD5 authentication in accordance with RFC1321. If this option is configured, then at least one message-digest-key must be configured.

## bfd-enable

**Syntax** **[no] bfd-enable [remain-down-on-failure]**

**Context** config>router>ospf>area>interface  
config>router>ospf3>area>interface

**Description** This command enables the use of bi-directional forwarding (BFD) to control the state of the associated protocol interface. By enabling BFD on a given protocol interface, the state of the protocol interface is tied to the state of the BFD session between the local node and the remote node. The parameters used for the BFD are set via the BFD command under the IP interface.

The **no** form of this command removes BFD from the associated IGP protocol adjacency.

**Default** **no bfd-enable**

**Parameters** **remain-down-on-failure** — Forces adjacency down on BFD failure.

## dead-interval

**Syntax** **dead-interval** *seconds*  
**no dead-interval**

**Context** config>router>ospf>area>interface  
config>router>ospf3>area>interface  
config>router>ospf>area>virtual-link  
config>router>ospf3>area>virtual-link

**Description** This command configures the time, in seconds, that OSPF waits before declaring a neighbor router down. If no hello packets are received from a neighbor for the duration of the dead interval, the router is assumed to be down. The minimum interval must be two times the hello interval.

The **no** form of the command reverts to the default value.

**Default** **40** seconds

**Special Cases** **OSPF Interface** — If the **dead-interval** configured applies to an interface, then all nodes on the subnet must have the same dead interval.

**Virtual Link** — If the **dead-interval** configured applies to a virtual link, then the interval on both termination points of the virtual link must have the same dead interval.

## Interface/Virtual Link Commands

**Parameters** *seconds* — The dead interval expressed in seconds.

**Values** 1 — 65535

### export

**Syntax** **[no] export** *policy-name* [*policy-name*...up to 5 max]

**Context** config>router>ospf

**Description** This command configures export routing policies that determine the routes exported from the routing table to OSPF.

If no export policy is defined, non OSPF routes are not exported from the routing table manager to IS-IS.

If multiple policy names are specified, the policies are evaluated in the order they are specified. The first policy that matches is applied. If multiple export commands are issued, the last command entered overrides the previous command. A maximum of five policy names can be specified.

If an **aggregate** command is also configured in the **config>router** context, then the aggregation is applied before the export policy is applied.

Routing policies are created in the **config>router>policy-options** context.

The **no** form of the command removes the specified *policy-name* or all policies from the configuration if no *policy-name* is specified.

**Default** **no export** — No export policy name is specified.

**Parameters** *policy-name* — The export policy name. Up to five *policy-name* arguments can be specified.

### export-limit

**Syntax** **export-limit** *number* [**log** *percentage*]  
**no export-limit**

**Context** config>router>ospf

**Description** This command configures the maximum number of routes (prefixes) that can be exported into OSPF from the route table.

The **no** form of the command removes the parameters from the configuration.

**Default** no export-limit, the export limit for routes or prefixes is disabled.

**Parameters** *number* — Specifies the maximum number of routes (prefixes) that can be exported into OSPF from the route table.

**Values** 1 — 4294967295

**log percentage** — Specifies the percentage of the export-limit, at which a warning log message and SNMP notification would be sent.

**Values** 1 — 100

## hello-interval

|                      |                                                                                                                                                                                                                                                                                                                                                                                                                                                                                                                                                                                           |
|----------------------|-------------------------------------------------------------------------------------------------------------------------------------------------------------------------------------------------------------------------------------------------------------------------------------------------------------------------------------------------------------------------------------------------------------------------------------------------------------------------------------------------------------------------------------------------------------------------------------------|
| <b>Syntax</b>        | <b>hello-interval</b> <i>seconds</i><br><b>no hello-interval</b>                                                                                                                                                                                                                                                                                                                                                                                                                                                                                                                          |
| <b>Context</b>       | config>router>ospf>area>interface<br>config>router>ospf3>area>interface<br>config>router>ospf>area>virtual-link<br>config>router>ospf3>area>virtual-link                                                                                                                                                                                                                                                                                                                                                                                                                                  |
| <b>Description</b>   | This command configures the interval between OSPF hellos issued on the interface or virtual link.<br><br>The hello interval, in combination with the dead-interval, is used to establish and maintain the adjacency. Use this parameter to edit the frequency that hello packets are sent.<br><br>Reducing the interval, in combination with an appropriate reduction in the associated <b>dead-interval</b> , allows for faster detection of link and/or router failures at the cost of higher processing costs.<br><br>The <b>no</b> form of this command reverts to the default value. |
| <b>Default</b>       | <b>hello-interval 10</b> — A 10-second hello interval.                                                                                                                                                                                                                                                                                                                                                                                                                                                                                                                                    |
| <b>Special Cases</b> | <b>OSPF Interface</b> — If the <b>hello-interval</b> configured applies to an interface, then all nodes on the subnet must have the same hello interval.<br><br><b>Virtual Link</b> — If the <b>hello-interval</b> configured applies to a virtual link, then the interval on both termination points of the virtual link must have the same hello interval.                                                                                                                                                                                                                              |
| <b>Parameters</b>    | <i>seconds</i> — The hello interval in seconds expressed as a decimal integer.<br><br><b>Values</b> 1 — 65535                                                                                                                                                                                                                                                                                                                                                                                                                                                                             |

## interface

|                    |                                                                                                                                                                                                                                                                                                                                                                                                                                                                      |
|--------------------|----------------------------------------------------------------------------------------------------------------------------------------------------------------------------------------------------------------------------------------------------------------------------------------------------------------------------------------------------------------------------------------------------------------------------------------------------------------------|
| <b>Syntax</b>      | <b>[no] interface</b> <i>ip-int-name</i> [ <b>secondary</b> ]                                                                                                                                                                                                                                                                                                                                                                                                        |
| <b>Context</b>     | config>router>ospf>area<br>config>router>ospf3>area                                                                                                                                                                                                                                                                                                                                                                                                                  |
| <b>Description</b> | This command creates a context to configure an OSPF interface.<br><br>By default, interfaces are not activated in any interior gateway protocol, such as OSPF, unless explicitly configured.<br><br>The <b>no</b> form of the command deletes the OSPF interface configuration for this interface. The <b>shutdown</b> command in the config>router>ospf>interface context can be used to disable an interface without removing the configuration for the interface. |
| <b>Default</b>     | <b>no interface</b> — No OSPF interfaces are defined.                                                                                                                                                                                                                                                                                                                                                                                                                |
| <b>Parameters</b>  | <i>ip-int-name</i> — The IP interface name. Interface names must be unique within the group of defined IP interfaces for <b>config router interface</b> and <b>config service ies interface</b> commands. An interface name cannot be in the form of an IP address. Interface names can be any string up to 32 characters long                                                                                                                                       |

## Interface/Virtual Link Commands

composed of printable, 7-bit ASCII characters. If the string contains special characters (#, \$, spaces, etc.), the entire string must be enclosed within double quotes.

If the IP interface name does not exist or does not have an IP address configured an error message will be returned.

If the IP interface exists in a different area it will be moved to this area.

secondary — Allows multiple secondary adjacencies to be established over a single IP interface.

### interface-type

|                      |                                                                                                                                                                                                                                                                                                                                                                                                                                                                                                                                                                                                                |
|----------------------|----------------------------------------------------------------------------------------------------------------------------------------------------------------------------------------------------------------------------------------------------------------------------------------------------------------------------------------------------------------------------------------------------------------------------------------------------------------------------------------------------------------------------------------------------------------------------------------------------------------|
| <b>Syntax</b>        | <b>interface-type</b> { <b>broadcast</b>   <b>point-to-point</b> }<br><b>no interface-type</b>                                                                                                                                                                                                                                                                                                                                                                                                                                                                                                                 |
| <b>Context</b>       | config>router>ospf>area>interface<br>config>router>ospf3>area>interface                                                                                                                                                                                                                                                                                                                                                                                                                                                                                                                                        |
| <b>Description</b>   | This command configures the interface type to be either broadcast or point-to-point.<br><br>Use this command to set the interface type of an Ethernet link to point-to-point to avoid having to carry the broadcast adjacency maintenance overhead of the Ethernet link provided the link is used as a point-to-point.<br><br>If the interface type is not known at the time the interface is added to OSPF and subsequently the IP interface is bound (or moved) to a different interface type, this command must be entered manually.<br><br>The <b>no</b> form of the command reverts to the default value. |
| <b>Default</b>       | <b>point-to-point</b> if the physical interface is SONET.<br><b>broadcast</b> if the physical interface is Ethernet or unknown.                                                                                                                                                                                                                                                                                                                                                                                                                                                                                |
| <b>Special Cases</b> | <b>Virtual-Link</b> — A virtual link is always regarded as a point-to-point interface and not configurable.                                                                                                                                                                                                                                                                                                                                                                                                                                                                                                    |
| <b>Parameters</b>    | <b>broadcast</b> — Configures the interface to maintain this link as a broadcast network. To significantly improve adjacency forming and network convergence, a network should be configured as point-to-point if only two routers are connected, even if the network is a broadcast media such as Ethernet.<br><br><b>point-to-point</b> — Configures the interface to maintain this link as a point-to-point link.                                                                                                                                                                                           |

### message-digest-key

|                    |                                                                                                                                                                                                                                                             |
|--------------------|-------------------------------------------------------------------------------------------------------------------------------------------------------------------------------------------------------------------------------------------------------------|
| <b>Syntax</b>      | <b>message-digest-key</b> <i>keyid</i> <b>md5</b> [ <i>key</i>   <i>hash-key</i> ] [ <b>hash</b> ]<br><b>no message-digest-key</b> <i>keyid</i>                                                                                                             |
| <b>Context</b>     | config>router>ospf>area>interface<br>config>router>ospf>area>virtual-link                                                                                                                                                                                   |
| <b>Description</b> | This command configures a message digest key when MD5 authentication is enabled on the interface. Multiple message digest keys can be configured.<br><br>The <b>no</b> form of the command removes the message digest key identified by the <i>key-id</i> . |

**Default** No message digest keys are defined.

**Parameters** **keyid** — The *keyid* is expressed as a decimal integer.

**Values** 1 — 255

**md5 key** — The MD5 key. The *key* can be any alphanumeric string up to 16 characters in length.

**md5 hash-key** — The MD5 hash key. The key can be any combination of ASCII characters up to 32 characters in length (encrypted). If spaces are used in the string, enclose the entire string in quotation marks (“ ”).

This is useful when a user must configure the parameter, but, for security purposes, the actual unencrypted key value is not provided.

**hash** — Specifies the key is entered in an encrypted form. If the **hash** parameter is not used, the key is assumed to be in a non-encrypted, clear text form. For security, all keys are stored in encrypted form in the configuration file with the **hash** parameter specified.

## metric

**Syntax** **metric** *metric*  
**no metric**

**Context** config>router>ospf>area>interface  
config>router>ospf3>area>interface

**Description** This command configures an explicit route cost metric for the OSPF interface that overrides the metrics calculated based on the speed of the underlying link.

The **no** form of the command deletes the manually configured interface metric, so the interface uses the computed metric based on the **reference-bandwidth** command setting and the speed of the underlying link.

**Default** **no metric** — The metric is based on **reference-bandwidth** setting and the link speed.

**Parameters** *metric* — The metric to be applied to the interface expressed as a decimal integer.

**Values** 1 — 65535

## mtu

**Syntax** **mtu** *bytes*  
**no mtu**

**Context** config>router>ospf>area>interfac  
config>router>ospf3>area>interface

**Description** This command configures the OSPF packet size used on this interface. If this parameter is not configured OSPF derives the MTU value from the MTU configured (default or explicitly) in the following contexts:

config>port>ethernet  
config>port>sonet-sdh>path

## Interface/Virtual Link Commands

```
config>port>tdm>t3-e3
config>port>tdm>t1-e1>channel-group
```

If this parameter is configured, the smaller value between the value configured here and the MTU configured (default or explicitly) in an above-mentioned context is used.

To determine the actual packet size add 14 bytes for an Ethernet packet and 18 bytes for a tagged Ethernet packet to the size of the OSPF (IP) packet MTU configured in this command.

Use the **no** form of this command to revert to default.

**Default** **no mtu** — Uses the value derived from the MTU configured in the **config>port** context.

**Parameters** *bytes* — The MTU to be used by OSPF for this logical interface in bytes.

**Values** 512 — 9198 (9212 — 14) (Depends on the physical media)

## passive

**Syntax** [**no**] **passive**

**Context** config>router>ospf>area>interface  
config>router>ospf3>area>interface

**Description** This command adds the passive property to the OSPF interface where passive interfaces are advertised as OSPF interfaces but do not run the OSPF protocol.

By default, only interface addresses that are configured for OSPF will be advertised as OSPF interfaces. The **passive** parameter allows an interface to be advertised as an OSPF interface without running the OSPF protocol.

While in passive mode, the interface will ignore ingress OSPF protocol packets and not transmit any OSPF protocol packets.

The **no** form of the command removes the passive property from the OSPF interface.

**Default** Service interfaces defined in **config>router>service-prefix** are passive.  
All other interfaces are not passive.

## priority

**Syntax** **priority** *number*  
**no priority**

**Context** config>router>ospf>area>interface  
config>router>ospf3>area>interface

**Description** This command configures the priority of the OSPF interface that is used in an election of the designated router on the subnet.



This parameter is only used if the interface is of type broadcast. The router with the highest priority interface becomes the designated router. A router with priority 0 is not eligible to be Designated Router or Backup Designated Router.

The **no** form of the command reverts the interface priority to the default value.

**Default** **priority 1**

**Parameters** *number* — The interface priority expressed as a decimal integer. A value of 0 indicates the router is not eligible to be the Designated Router or Backup Designated Router on the interface subnet.

**Values** 0 — 255

## retransmit-interval

**Syntax** **retransmit-interval** *seconds*  
**no retransmit-interval**

**Context** config>router>ospf>area>interface  
config>router>ospf3>area>interface  
config>router>ospf>area>virtual-link  
config>router>ospf3>area>virtual-link

**Description** This command specifies the length of time, in seconds, that OSPF will wait before retransmitting an unacknowledged link state advertisement (LSA) to an OSPF neighbor.

The value should be longer than the expected round trip delay between any two routers on the attached network. Once the retransmit-interval expires and no acknowledgement has been received, the LSA will be retransmitted.

The **no** form of this command reverts to the default interval.

**Default** **retransmit-interval 5**

**Parameters** *seconds* — The retransmit interval in seconds expressed as a decimal integer.

**Values** 1 — 1800

## transit-delay

**Syntax** **transit-delay** *seconds*  
**no transit-delay**

**Context** config>router>ospf>area>interface  
config>router>ospf3>area>interface  
config>router>ospf>area>virtual-link  
config>router>ospf3>area>virtual-link

**Description** This command configures the estimated time, in seconds, that it takes to transmit a link state advertisement (LSA) on the interface or virtual link.

The **no** form of this command reverts to the default delay time

## Interface/Virtual Link Commands

**Default** transit-delay 1

**Parameters** *seconds* — The transit delay in seconds expressed as a decimal integer.

**Values** 1 — 1800

### virtual-link

**Syntax** [no] virtual-link *router-id* transit-area *area-id*

**Context** config>router>ospf>area  
config>router>ospf3>area

**Description** This command configures a virtual link to connect area border routers to the backbone via a virtual link.

The backbone area (area 0.0.0.0) must be contiguous and all other areas must be connected to the backbone area. If it is not practical to connect an area to the backbone (see area 0.0.0.2 in the picture below) then the area border routers (routers 1 and 2 in the picture below) must be connected via a virtual link. The two area border routers will form a point-to-point like adjacency across the transit area. (area 0.0.0.1 in the picture below). A virtual link can only be configured while in the area 0.0.0.0 context.

The *router-id* specified in this command must be associated with the virtual neighbor. The transit area cannot be a stub area or a Not So Stubby Area (NSSA).

The **no** form of the command deletes the virtual link. (*Default: none specified*)

**Default** No virtual link is defined.

**Parameters** *router-id* — The router ID of the virtual neighbor in IP address dotted decimal notation.

**transit-area** *area-id* — The area-id specified identifies the transit area that links the backbone area with the area that has no physical connection with the backbone.

The OSPF backbone area, area 0.0.0.0, must be contiguous and all other areas must be connected to the backbone area. The backbone distributes routing information between areas. If it is not practical to connect an area to the backbone (see Area 0.0.0.5 in [Figure 14](#)) then the area border routers (such as routers Y and Z) must be connected via a virtual link. The two area border routers form a point-to-point-like adjacency across the transit area (see Area 0.0.0.4).

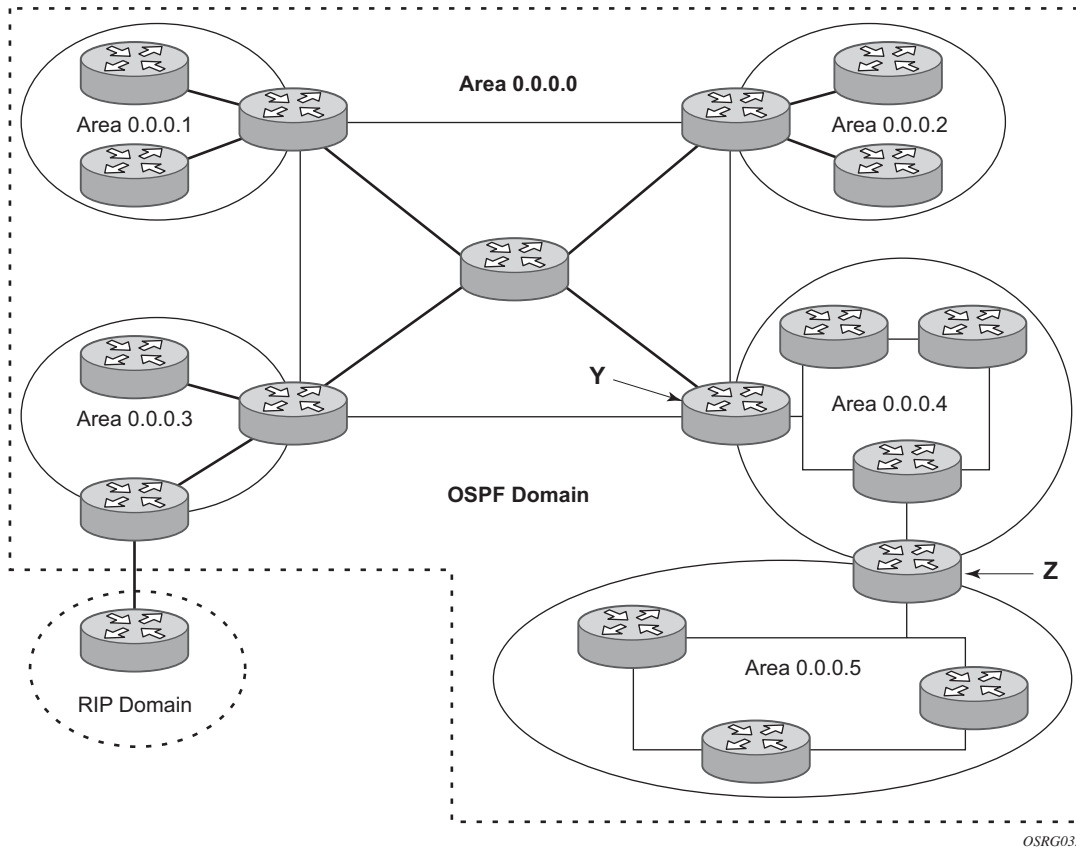

Figure 14: OSPF Areas



---

## Show Commands

### ospf

**Syntax** `ospf [ospf-instance]`

**Context** show>router

**Description** This command enables the context to display OSPF information.

**Parameters** *ospf-instance* — Clears the configured specified VR-ID.

**Values** 1 — 4294967295

### area

**Syntax** `area [area-id] [detail] [lfa]`

**Context** show>router>ospf  
show>router>ospf3

**Description** This command displays configuration information about all areas or the specified area. When detail is specified operational and statistical information will be displayed.

**Parameters** *area-id* — The OSPF area ID expressed in dotted decimal notation or as a 32-bit decimal integer.

**detail** — Displays detailed information about the specified area.

**lfa** — Displays Loop-Free Alternate (LFA) next-hop information.

**Output** **OSPF Area Output** — The following table describes the standard and detailed command output fields for an OSPF area.

| Label     | Description                                                                                                                                                                    |
|-----------|--------------------------------------------------------------------------------------------------------------------------------------------------------------------------------|
| Area Id   | A 32 bit integer uniquely identifying an area.                                                                                                                                 |
| Type      | NSSA — This area is configured as an NSSA area.<br>Standard — This area is configured as a standard area (not NSSA or Stub).<br>Stub — This area is configured as a stub area. |
| SPF Runs  | The number of times that the intra-area route table has been calculated using this area's link state database.                                                                 |
| LSA Count | The total number of link-state advertisements in this area's link state database, excluding AS External LSA's.                                                                 |

## Show Commands

| Label             | Description (Continued)                                                                                                                                                              |
|-------------------|--------------------------------------------------------------------------------------------------------------------------------------------------------------------------------------|
| LSA Cksum Sum     | The 32-bit unsigned sum of the link-state database advertisements LS checksums contained in this area's link state database. This checksum excludes AS External LSAs (type-5).       |
| No. of OSPF Areas | The number of areas configured on the router.                                                                                                                                        |
| Virtual Links     | The number of virtual links configured through this transit area.                                                                                                                    |
| Active IFs        | The active number of interfaces configured in this area.                                                                                                                             |
| Area Bdr Rtrs     | The total number of ABRs reachable within this area.                                                                                                                                 |
| AS Bdr Rtrs       | The total number of ASBRs reachable within this area.                                                                                                                                |
| Last SPF Run      | The time when the last intra-area SPF was run on this area.                                                                                                                          |
| Router LSAs       | The total number of router LSAs in this area.                                                                                                                                        |
| Network LSAs      | The total number of network LSAs in this area.                                                                                                                                       |
| Summary LSAs      | The summary of LSAs in this area.                                                                                                                                                    |
| Asbr-summ LSAs    | The summary of ASBR LSAs in this area.                                                                                                                                               |
| Nssa-ext LSAs     | The total number of NSSA-EXT LSAs in this area.                                                                                                                                      |
| Area opaque LSAs  | The total number of opaque LSAs in this area.                                                                                                                                        |
| Total Nbrs        | The total number of neighbors in this area.                                                                                                                                          |
| Total IFs         | The total number of interfaces configured in this area.                                                                                                                              |
| Total LSAs        | The sum of LSAs in this area excluding autonomous system external LSAs.                                                                                                              |
| Blackhole Range   | False – No blackhole route is installed for aggregates configured in this area.<br><br>True – A lowest priority blackhole route is installed for aggregates configured in this area. |

### Sample Output

```
A:SetupCLI# show router ospf area detail
=====
OSPF Areas (Detailed)
=====

Area Id: 0.0.0.0

Area Id : 0.0.0.0 Type : Standard
Key Rollover Int.: 10 LFA : Include
Virtual Links : 0 Total Nbrs : 0
Active IFs : 0 Total IFs : 2
```

```

Area Bdr Rtrs : 0
SPF Runs : 0
Router LSAs : 0
Summary LSAs : 0
Nssa ext LSAs : 0
Total LSAs : 1
Blackhole Range : True
AS Bdr Rtrs : 0
Last SPF Run : Never
Network LSAs : 0
Asbr-summ LSAs : 0
Area opaque LSAs : 1
LSA Cksum Sum : 0xd6af
Unknown LSAs : 0

```

```

Area Id: 1.1.1.1

```

```

Area Id : 1.1.1.1
Default Cost : 16777215
Key Rollover Int.: 10
Virtual Links : 0
Active IFs : 0
Area Bdr Rtrs : 0
SPF Runs : 0
Router LSAs : 0
Summary LSAs : 0
Nssa ext LSAs : 0
Total LSAs : 1
Blackhole Range : False
Type : Stub
Import Summary : Send Summary
LFA : Exclude
Total Nbrs : 0
Total IFs : 1
AS Bdr Rtrs : 0
Last SPF Run : Never
Network LSAs : 0
Asbr-summ LSAs : 0
Area opaque LSAs : 1
LSA Cksum Sum : 0xf493
Unknown LSAs : 0

```

```

Area Id: 2.2.2.2

```

```

Area Id : 2.2.2.2
Key Rollover Int.: 10
Virtual Links : 1
Active IFs : 0
Area Bdr Rtrs : 0
SPF Runs : 0
Router LSAs : 0
Summary LSAs : 0
Nssa ext LSAs : 0
Total LSAs : 1
Blackhole Range : True
Type : Standard
LFA : Include
Total Nbrs : 0
Total IFs : 0
AS Bdr Rtrs : 0
Last SPF Run : Never
Network LSAs : 0
Asbr-summ LSAs : 0
Area opaque LSAs : 1
LSA Cksum Sum : 0xd6af
Unknown LSAs : 0

```

```
=====
A:SetupCLI#
```

```
A:SR# show router ospf area detail
```

```
=====
OSPF Areas (Detailed)
=====
```

```

Area Id: 0.0.0.0

```

```

Area Id : 0.0.0.0
Virtual Links : 0
Active IFs : 3
Area Bdr Rtrs : 0
SPF Runs : 7
Router LSAs : 3
Summary LSAs : 0
Nssa ext LSAs : 0
Total LSAs : 9
Blackhole Range : True
Type : Standard
Total Nbrs : 2
Total IFs : 3
AS Bdr Rtrs : 0
Last SPF Run : 10/26/2006 10:09:18
Network LSAs : 3
Asbr-summ LSAs : 0
Area opaque LSAs : 3
LSA Cksum Sum : 0x28b62
Unknown LSAs : 0

```

```
=====
*A:Bombadil# show router ospf area 0.0.0.0 detail

```

## Show Commands

```
=====
OSPF Area (Detailed) : 0.0.0.0
=====

Configuration

Area Id : 0.0.0.0 Type : Standard

Statistics

Virtual Links : 0 Total Nbrs : 2
Active IFs : 3 Total IFs : 3
Area Bdr Rtrs : 0 AS Bdr Rtrs : 0
SPF Runs : 7 Last SPF Run : 10/26/2006 10:09:18
Router LSAs : 3 Network LSAs : 3
Summary LSAs : 0 Asbr-summ LSAs : 0
Nssa ext LSAs : 0 Area opaque LSAs : 3
Total LSAs : 9 LSA Cksum Sum : 0x28b62
Blackhole Range : True Unknown LSAs : 0
=====
```

```
*A:Dut-B# show router ospf area 0.0.0.0 lfa
```

```

Path Table
=====
```

| Node      | Interface<br>LFA Interface | Nexthop<br>LFA Nexthop |
|-----------|----------------------------|------------------------|
| 10.20.1.1 | to_Dut-A1                  | 10.20.1.1              |
|           | to_Dut-C1                  | 10.20.1.3              |
| 10.20.1.3 | to_Dut-C1                  | 10.20.1.3              |
|           | to_Dut-A1                  | 10.20.1.1              |
| 10.20.1.4 | to_Dut-D1                  | 10.20.1.4              |
| 10.20.1.6 | to_Dut-D1                  | 10.20.1.4              |
|           | to_Dut-C1                  | 10.20.1.3              |

```

*A:Dut-B#
```

```
*A:Dut-B# show router ospf area 0.0.0.0 lfa detail
```

```

Path Table
=====
```

```
OSPF Area : 0.0.0.0
```

```

Node : 10.20.1.1 Metric : 10
Interface : to_Dut-A1 Nexthop : 10.20.1.1
LFA Interface : to_Dut-C1 LFA Metric : 20
LFA type : linkProtection LFA Nexthop : 10.20.1.3
```

```
Node : 10.20.1.3 Metric : 10
Interface : to_Dut-C1 Nexthop : 10.20.1.3
LFA Interface : to_Dut-A1 LFA Metric : 20
LFA type : linkProtection LFA Nexthop : 10.20.1.1
```

```
Node : 10.20.1.4 Metric : 10
```



```

Interface : to_Dut-D1 Nexthop : 10.20.1.4
Node : 10.20.1.6 Metric : 20
Interface : to_Dut-D1 Nexthop : 10.20.1.4
LFA Interface : to_Dut-C1 LFA Metric : 30
LFA type : nodeProtection LFA Nexthop : 10.20.1.3

```

```

=====
*A:Dut-B#

```

## database

**Syntax** **database** [**type** {**router** | **network** | **summary** | **asbr-summary** | **external** | **nssa** | **all**}] [**area** *area-id*] [**adv-router** *router-id*] [*link-state-id*] [**detail**]

**Context** show>router>ospf  
show>router>ospf3

**Description** This command displays information about the OSPF link state database (LSDB).  
When no command line options are specified, the command displays brief output for all database entries

**Parameters** *ospf-instance* — The OSPF instance.

**Values** 1 — 4294967295

**type** *keyword* — Specifies to filter the OSPF LSDB information based on the type specified by *keyword*.

**type router** — Display only router (Type 1) LSAs in the LSDB.

**type network** — Display only network (Type 2) LSAs in the LSDB.

**type summary** — Display only summary (Type 3) LSAs in the LSDB.

**type asbr-summary** — Display only ASBR summary (Type 4) LSAs in the LSDB.

**type external** — Display only AS external (Type 5) LSAs in the LSDB. External LSAs are maintained globally and not per area. If the display of external links is requested, the area parameter, if present, is ignored.

**type nssa** — Displays only NSSA area-specific AS external (Type 7) LSAs in the LSDB.

**type all** — Display all LSAs in the LSDB. The all keyword is intended to be used with either the **area** *area-id* or the **adv-router** *router-id* [*link-state-id*] parameters.

**area** *area-id* — Display LSDB information associated with the specified OSPF *area-id*.

**adv-router** *router-id* [*link-state-id*] — Display LSDB information associated with the specified advertising router. To further narrow the number of items displayed, the *link-state-id* can optionally be specified.

**detail** — Displays detailed information on the LSDB entries.

## Show Commands

**Output OSPF Database Ouput** — The following table describes the standard and detailed command output fields for an OSPF database.

| Label                       | Description                                                                                                                                                                                                                                                                                                                                                                                                                                                                                                                                                               |
|-----------------------------|---------------------------------------------------------------------------------------------------------------------------------------------------------------------------------------------------------------------------------------------------------------------------------------------------------------------------------------------------------------------------------------------------------------------------------------------------------------------------------------------------------------------------------------------------------------------------|
| Area Id                     | The OSPF area identifier.                                                                                                                                                                                                                                                                                                                                                                                                                                                                                                                                                 |
| Type<br>LSA Type            | Router — LSA type of router (OSPF)<br><br>Network — LSA type of network (OSPF)<br><br>Summary — LSA type of summary (OSPF)<br><br>ASBR Summary — LSA type of ASBR summary (OSPF)<br><br>Nssa-ext — LSA area-specific, NSSA external (OSPF)<br><br>Area opaque — LSA type of area opaque (OSPF)<br><br>router — LSA type of router (OSPF3)<br><br>Network — LSA type of network (OSPF3)<br><br>IE Pfx — LSA type of IE Pfx (OSPF3) IE Rtr — LSA type of IE Rtr (OSPF3)<br><br>IA Pfx — LSA type of IA Pfx (OSPF3)<br><br>Nssa-ext — NSSA area-specific AS external (OSPF3) |
| Link State Id               | The link state Id is an LSA type specific field containing either a number to distinguish several LSAs from the same router, an interface ID, or a router-id; it identifies the piece of the routing domain being described by the advertisement.                                                                                                                                                                                                                                                                                                                         |
| Adv Rtr Id<br>Adv Router Id | The router identifier of the router advertising the LSA.                                                                                                                                                                                                                                                                                                                                                                                                                                                                                                                  |
| Age                         | The age of the link state advertisement in seconds.                                                                                                                                                                                                                                                                                                                                                                                                                                                                                                                       |
| Sequence<br>Sequence No     | The signed 32-bit integer sequence number.                                                                                                                                                                                                                                                                                                                                                                                                                                                                                                                                |
| Cksum<br>Checksum           | The 32-bit unsigned sum of the link-state advertisements' LS checksums.                                                                                                                                                                                                                                                                                                                                                                                                                                                                                                   |
| No. of LSAs                 | The number of LSAs displayed.                                                                                                                                                                                                                                                                                                                                                                                                                                                                                                                                             |
| Options                     | EA — External Attribute LSA Support<br><br>DC — Demand Circuit Support<br><br>R — If clear, a node can participates in OSPF topology distribution without being used to forward transit traffic.<br><br>N — Type 7 LSA Support                                                                                                                                                                                                                                                                                                                                            |

| Label          | Description (Continued)                                                                                                                                                                                                                                                                   |
|----------------|-------------------------------------------------------------------------------------------------------------------------------------------------------------------------------------------------------------------------------------------------------------------------------------------|
|                | MC – Multicast Support                                                                                                                                                                                                                                                                    |
|                | E – External Routes Support                                                                                                                                                                                                                                                               |
|                | V6 – V6 works in conjunction with R. If V6 is clear, a node can participate in OSPF topology distribution without being used to forward IPv6 datagrams. If R is set and V6 is clear, IPv6 datagrams are not forwarded but diagrams belonging to another protocol family may be forwarded. |
| Prefix Options | P – Propagate NSSA LSA.                                                                                                                                                                                                                                                                   |
|                | MC – Multicast support.                                                                                                                                                                                                                                                                   |
|                | LA – Lcal address capability. If set, the prefix is an IPv6 interface address of the advertising router.                                                                                                                                                                                  |
|                | NU – No unicast capability. If set, the prefix is excluded from IPv6 unicast calculations.                                                                                                                                                                                                |
| Flags          | None – No flags set                                                                                                                                                                                                                                                                       |
|                | V – The router is an endpoint for one or more fully adjacent Virtual Links having the described area as the transit area                                                                                                                                                                  |
|                | E – The router is an AS Boundary Router                                                                                                                                                                                                                                                   |
|                | B – The router is an Area Border Router                                                                                                                                                                                                                                                   |
| Link Count     | The number of links advertised in the LSA.                                                                                                                                                                                                                                                |
| Link Type (n)  | The link type of the <i>n</i> th link in the LSA.                                                                                                                                                                                                                                         |
| Network (n)    | The network address of the <i>n</i> th link in the LSA.                                                                                                                                                                                                                                   |
| Metric-0 (n)   | The cost metric of the <i>n</i> th link in the LSA.                                                                                                                                                                                                                                       |

### Sample Output

```
A:ALA-A# show router ospf 1 database
=====
OSPF Link State Database (Type : All)
=====
Area Id Type Link State Id Adv Rtr Id Age Sequence Cksm

0.0.0.0 Router 180.0.0.2 180.0.0.2 1800 0x800000b6 0xf54
0.0.0.0 Router 180.0.0.5 180.0.0.5 1902 0x8000009d 0xcb7c
0.0.0.0 Router 180.0.0.8 180.0.0.8 1815 0x8000009a 0x529b
0.0.0.0 Router 180.0.0.9 180.0.0.9 1156 0x80000085 0xd00f
0.0.0.0 Router 180.0.0.10 180.0.0.10 533 0x8000009d 0x3f1f
0.0.0.0 Router 180.0.0.11 180.0.0.11 137 0x80000086 0xc58f
0.0.0.0 Router 180.0.0.12 180.0.0.12 918 0x8000009d 0x4cf3
0.0.0.0 Router 180.0.0.13 180.0.0.13 1401 0x800000a2 0x879c
0.0.0.0 Network 180.0.53.28 180.0.0.28 149 0x80000083 0xe5cd
0.0.0.0 Network 180.0.54.28 180.0.0.28 1259 0x80000083 0xdad7
0.0.0.0 Summary 180.0.0.15 180.0.0.10 378 0x80000084 0xeba1
```

## Show Commands

```
0.0.0.0 Summary 180.0.0.15 180.0.0.12 73 0x80000084 0xdfab
0.0.0.0 Summary 180.0.0.18 180.0.0.10 1177 0x80000083 0xcfbb
0.0.0.1 Summary 180.100.25.4 180.0.0.12 208 0x80000091 0x3049
0.0.0.1 AS Summ 180.0.0.8 180.0.0.10 824 0x80000084 0x3d07
0.0.0.1 AS Summ 180.0.0.8 180.0.0.12 1183 0x80000095 0x4bdf
0.0.0.1 AS Summ 180.0.0.9 180.0.0.10 244 0x80000082 0x73cb
n/a AS Ext 7.1.0.0 180.0.0.23 1312 0x80000083 0x45e7
n/a AS Ext 7.2.0.0 180.0.0.23 997 0x80000082 0x45e6
n/a AS Ext 10.20.0.0 180.0.0.23 238 0x80000081 0x2d81
...

```

No. of LSAs: 339

=====  
A:ALA-A#

A:ALA-A# **show router ospf database detail**

=====  
OSPF Link State Database (Type : All) (Detailed)

-----  
Router LSA for Area 0.0.0.0

-----

|                |                  |                 |                 |
|----------------|------------------|-----------------|-----------------|
| Area Id        | : 0.0.0.0        | Adv Router Id   | : 180.0.0.2     |
| Link State Id  | : 180.0.0.2      | LSA Type        | : Router        |
| Sequence No    | : 0x800000b7     | Checksum        | : 0xd55         |
| Age            | : 155            | Length          | : 192           |
| Options        | : E              |                 |                 |
| Flags          | : None           | Link Count      | : 14            |
| Link Type (1)  | : Point To Point |                 |                 |
| Nbr Rtr Id (1) | : 180.0.0.13     | I/F Address (1) | : 180.0.22.2    |
| No of TOS (1)  | : 0              | Metric-0 (1)    | : 25            |
| Link Type (2)  | : Stub Network   |                 |                 |
| Network (2)    | : 180.0.22.0     | Mask (2)        | : 255.255.255.0 |
| No of TOS (2)  | : 0              | Metric-0 (2)    | : 25            |
| Link Type (3)  | : Point To Point |                 |                 |
| Nbr Rtr Id (3) | : 180.0.0.12     | I/F Address (3) | : 180.0.5.2     |
| No of TOS (3)  | : 0              | Metric-0 (3)    | : 25            |
| Link Type (4)  | : Stub Network   |                 |                 |
| Network (4)    | : 180.0.5.0      | Mask (4)        | : 255.255.255.0 |
| No of TOS (4)  | : 0              | Metric-0 (4)    | : 25            |
| Link Type (5)  | : Point To Point |                 |                 |
| Nbr Rtr Id (5) | : 180.0.0.8      | I/F Address (5) | : 180.0.13.2    |
| No of TOS (5)  | : 0              | Metric-0 (5)    | : 6             |
| Link Type (6)  | : Stub Network   |                 |                 |
| Network (6)    | : 180.0.13.0     | Mask (6)        | : 255.255.255.0 |
| No of TOS (6)  | : 0              | Metric-0 (6)    | : 6             |
| Link Type (7)  | : Point To Point |                 |                 |
| Nbr Rtr Id (7) | : 180.0.0.5      | I/F Address (7) | : 180.0.14.2    |
| No of TOS (7)  | : 0              | Metric-0 (7)    | : 6             |
| Link Type (8)  | : Stub Network   |                 |                 |
| Network (8)    | : 180.0.14.0     | Mask (8)        | : 255.255.255.0 |
| No of TOS (8)  | : 0              | Metric-0 (8)    | : 6             |
| Link Type (9)  | : Point To Point |                 |                 |
| Nbr Rtr Id (9) | : 180.0.0.11     | I/F Address (9) | : 180.0.17.2    |
| No of TOS (9)  | : 0              | Metric-0 (9)    | : 25            |
| Link Type (10) | : Stub Network   |                 |                 |
| Network (10)   | : 180.0.17.0     | Mask (10)       | : 255.255.255.0 |
| No of TOS (10) | : 0              | Metric-0 (10)   | : 25            |
| Link Type (11) | : Stub Network   |                 |                 |

-----

```

Network (11) : 180.0.0.2 Mask (11) : 255.255.255.255
No of TOS (11) : 0 Metric-0 (11) : 1
Link Type (12) : Stub Network
Network (12) : 180.0.18.0 Mask (12) : 255.255.255.0
No of TOS (12) : 0 Metric-0 (12) : 24
Link Type (13) : Point To Point
Nbr Rtr Id (13) : 180.0.0.10 I/F Address (13) : 180.0.3.2
No of TOS (13) : 0 Metric-0 (13) : 25
Link Type (14) : Stub Network
Network (14) : 180.0.3.0 Mask (14) : 255.255.255.0
No of TOS (14) : 0 Metric-0 (14) : 25

```

```

AS Ext LSA for Network 180.0.0.14

```

```

Area Id : N/A Adv Router Id : 180.0.0.10
Link State Id : 180.0.0.14 LSA Type : AS Ext
Sequence No : 0x80000083 Checksum : 0xa659
Age : 2033 Length : 36
Options : E
Network Mask : 255.255.255.255 Fwding Address : 180.1.6.15
Metric Type : Type 2 Metric-0 : 4
Ext Route Tag : 0

```

```

...
A:ALA-A#

```

## interface

**Syntax** `interface [ip-addr | ip-int-name | area area-id] [detail]`

**Context** show>router>ospf  
show>router>ospf3

**Description** Displays the details of the OSPF interface, this interface can be identified by ip-address or ip interface name. When neither is specified, all in-service interfaces are displayed.

The **detail** option produces a great amount of data. It is recommended to detail only when requesting a specific interface.

**Parameters** *ip-addr* — Display only the interface identified by this IP address.

*ip-int-name* — Display only the interface identified by this interface name.

**area area-id** — Display all interfaces configured in this area.

**detail** — Displays detailed information on the interface.

**Output** **Standard OSPF Interface Output** — The following table describes the standard command output fields for an OSPF interface.

| Label   | Description                                                                                                                         |
|---------|-------------------------------------------------------------------------------------------------------------------------------------|
| If Name | The interface name.                                                                                                                 |
| Area Id | A 32-bit integer uniquely identifying the area to which this interface is connected. Area ID 0.0.0.0 is used for the OSPF backbone. |

## Show Commands

| Label                  | Description (Continued)                                                                                                                                                                                                                                                                                                                                                                                                                                                                                                                                                                                                                                           |
|------------------------|-------------------------------------------------------------------------------------------------------------------------------------------------------------------------------------------------------------------------------------------------------------------------------------------------------------------------------------------------------------------------------------------------------------------------------------------------------------------------------------------------------------------------------------------------------------------------------------------------------------------------------------------------------------------|
| D Rtr Id               | The IP Interface address of the router identified as the Designated Router for the network in which this interface is configured. Set to 0.0.0.0 if there is no Designated router.                                                                                                                                                                                                                                                                                                                                                                                                                                                                                |
| BD Rtr Id              | The IP Interface address of the router identified as the Backup Designated Router for the network in which this interface is configured. Set to 0.0.0.0 if there is no Backup Designated router.                                                                                                                                                                                                                                                                                                                                                                                                                                                                  |
| Adm                    | Dn – OSPF on this interface is administratively shut down.<br>Up – OSPF on this interface is administratively enabled.                                                                                                                                                                                                                                                                                                                                                                                                                                                                                                                                            |
| Opr                    | Down – This is the initial interface state. In this state, the lower-level protocols have indicated that the interface is unusable.<br>wait – The router is trying to determine the identity of the (Backup) Designated router for the network.<br>PToP – The interface is operational, and connects either to a physical point-to-point network or to a virtual link.<br>DR – This router is the Designated Router for this network.<br>BDR – This router is the backup Designated Router for this network.<br>ODR – The interface is operational and part of a broadcast or NBMA network on which another router has been selected to be the Designated Router. |
| No. of OSPF Interfaces | The number of interfaces listed.                                                                                                                                                                                                                                                                                                                                                                                                                                                                                                                                                                                                                                  |

### Sample Output

```
A:SetupCLI# show router ospf interface "ip_if_1" detail
=====
OSPF Interface (Detailed) : ip_if_1
=====

Configuration

IP Address : 10.10.1.1
Area Id : 0.0.0.0
Hello Intrvl : 9 sec
Retrans Intrvl : 10 sec
Cfg Metric : 11
Transit Delay : 2
Passive : False
LFA : Exclude
IPsec InStatSA :
IPsec InStatSAmp:
Priority : 10
Rtr Dead Intrvl : 45 sec
Poll Intrvl : 120 sec
Advert Subnet : True
Auth Type : MD5
Cfg MTU : 9198
IPsec OutStatSA :

State
```

```

Admin Status : Enabled Oper State : Down
Designated Rtr : 0.0.0.0 Backup Desig Rtr : 0.0.0.0
IF Type : Secondary Network Type : Stub
Oper MTU : 1576 Last Enabled : Never
Oper Metric : 11 Bfd Enabled : No
Te Metric : 16777215 Te State : Down
Admin Groups : None
Ldp Sync : outOfService Ldp Sync Wait : Disabled
Ldp Timer State : Disabled Ldp Tm Left : 0

```

#### Statistics

```

Nbr Count : 0 If Events : 0
Tot Rx Packets : 0 Tot Tx Packets : 0
Rx Hellos : 0 Tx Hellos : 0
Rx DBDs : 0 Tx DBDs : 0
Rx LSRs : 0 Tx LSRs : 0
Rx LSUs : 0 Tx LSUs : 0
Rx LS Acks : 0 Tx LS Acks : 0
Retransmits : 0 Discards : 0
Bad Networks : 0 Bad Virt Links : 0
Bad Areas : 0 Bad Dest Adrs : 0
Bad Auth Types : 0 Auth Failures : 0
Bad Neighbors : 0 Bad Pkt Types : 0
Bad Lengths : 0 Bad Hello Int. : 0
Bad Dead Int. : 0 Bad Options : 0
Bad Versions : 0 Bad Checksums : 0
LSA Count : 0 LSA Checksum : 0x0

```

#### Configuration

```

IP Address : 10.10.1.1
Area Id : 1.1.1.1 Priority : 10
Hello Intrvl : 9 sec Rtr Dead Intrvl : 45 sec
Retrans Intrvl : 10 sec Poll Intrvl : 120 sec
Cfg Metric : 11 Advert Subnet : False
Transit Delay : 2 Auth Type : MD5
Passive : False Cfg MTU : 9198
LFA : Exclude
IPsec InStatSA : IPsec OutStatSA :
IPsec InStatSAmp:

```

#### State

```

Admin Status : Enabled Oper State : Down
Designated Rtr : 0.0.0.0 Backup Desig Rtr : 0.0.0.0
IF Type : Point To Point Network Type : Stub
Oper MTU : 1576 Last Enabled : Never
Oper Metric : 11 Bfd Enabled : No
Te Metric : 16777215 Te State : Down
Admin Groups : None
Ldp Sync : outOfService Ldp Sync Wait : Disabled
Ldp Timer State : Disabled Ldp Tm Left : 0

```

#### Statistics

```

Nbr Count : 0 If Events : 0
Tot Rx Packets : 0 Tot Tx Packets : 0

```

## Show Commands

```
Rx Hellos : 0
Rx DBDs : 0
Rx LSRs : 0
Rx LSUs : 0
Rx LS Acks : 0
Retransmits : 0
Bad Networks : 0
Bad Areas : 0
Bad Auth Types : 0
Bad Neighbors : 0
Bad Lengths : 0
Bad Dead Int. : 0
Bad Versions : 0
LSA Count : 0

Tx Hellos : 0
Tx DBDs : 0
Tx LSRs : 0
Tx LSUs : 0
Tx LS Acks : 0
Discards : 0
Bad Virt Links : 0
Bad Dest Adrs : 0
Auth Failures : 0
Bad Pkt Types : 0
Bad Hello Int. : 0
Bad Options : 0
Bad Checksums : 0
LSA Checksum : 0x0
=====
A:SetupCLI#

A:SetupCLI# show router ospf interface area 1.1.1.1 detail
=====
OSPF Interfaces in Area (Detailed) : 1.1.1.1
=====

Interface : ip_if_1

IP Address : 10.10.1.1
Area Id : 1.1.1.1
Hello Intrvl : 9 sec
Retrans Intrvl : 10 sec
Cfg Metric : 11
Transit Delay : 2
Passive : False
LFA : Exclude
IPsec InStatSA :
IPsec InStatSATmp:
Admin Status : Enabled
Designated Rtr : 0.0.0.0
IF Type : Point To Point
Oper MTU : 1576
Oper Metric : 11
Te Metric : 16777215
Admin Groups : None
Ldp Sync : outOfService
Ldp Timer State : Disabled
Nbr Count : 0
Tot Rx Packets : 0
Rx Hellos : 0
Rx DBDs : 0
Rx LSRs : 0
Rx LSUs : 0
Rx LS Acks : 0
Retransmits : 0
Bad Networks : 0
Bad Areas : 0
Bad Auth Types : 0
Bad Neighbors : 0
Bad Lengths : 0
Bad Dead Int. : 0
Bad Versions : 0

Priority : 10
Rtr Dead Intrvl : 45 sec
Poll Intrvl : 120 sec
Advert Subnet : False
Auth Type : MD5
Cfg MTU : 9198
IPsec OutStatSA :
Oper State : Down
Backup Desig Rtr : 0.0.0.0
Network Type : Stub
Last Enabled : Never
Bfd Enabled : No
Te State : Down
Ldp Sync Wait : Disabled
Ldp Tm Left : 0
If Events : 0
Tot Tx Packets : 0
Tx Hellos : 0
Tx DBDs : 0
Tx LSRs : 0
Tx LSUs : 0
Tx LS Acks : 0
Discards : 0
Bad Virt Links : 0
Bad Dest Adrs : 0
Auth Failures : 0
Bad Pkt Types : 0
Bad Hello Int. : 0
Bad Options : 0
Bad Checksums : 0
```



```

LSA Count : 0 LSA Checksum : 0x0
=====
A:SetupCLI#

A:SetupCLI# show router ospf 1 interface detail
=====
OSPF Interfaces (Detailed)

Interface : system

IP Address : 9.1.255.255
Area Id : 0.0.0.0 Priority : 1
Hello Intrvl : 10 sec Rtr Dead Intrvl : 40 sec
Retrans Intrvl : 5 sec Poll Intrvl : 120 sec
Cfg Metric : 0 Advert Subnet : True
Transit Delay : 1 Auth Type : None
Passive : True Cfg MTU : 0
Admin Status : Enabled Oper State : Designated Rtr
Designated Rtr : 2.2.2.2 Backup Desig Rtr : 0.0.0.0
IF Type : Broadcast Network Type : Transit
Oper MTU : 1500 Last Enabled : 05/14/2006 09:16:26
Oper Metric : 0 Bfd Enabled : No
Nbr Count : 0 If Events : 5
Tot Rx Packets : 0 Tot Tx Packets : 0
Rx Hellos : 0 Tx Hellos : 0
Rx DBDs : 0 Tx DBDs : 0
Rx LSRs : 0 Tx LSRs : 0
Rx LSUs : 0 Tx LSUs : 0
Rx LS Acks : 0 Tx LS Acks : 0
Retransmits : 0 Discards : 0
Bad Networks : 0 Bad Virt Links : 0
Bad Areas : 0 Bad Dest Addrs : 0
Bad Auth Types : 0 Auth Failures : 0
Bad Neighbors : 0 Bad Pkt Types : 0
Bad Lengths : 0 Bad Hello Int. : 0
Bad Dead Int. : 0 Bad Options : 0
Bad Versions : 0 Bad Checksums : 0
LSA Count : 0 LSA Checksum : 0x0

Interface : sender

IP Address : 11.1.1.1
Area Id : 0.0.0.0 Priority : 1
Hello Intrvl : 10 sec Rtr Dead Intrvl : 40 sec
Retrans Intrvl : 5 sec Poll Intrvl : 120 sec
Cfg Metric : 0 Advert Subnet : True
Transit Delay : 1 Auth Type : None
Passive : False Cfg MTU : 0
=====
A:SetupCLI#

```

**Detailed OSPF Interface Output** — The following table describes the detailed command output fields for an OSPF interface.

| Label     | Description                            |
|-----------|----------------------------------------|
| Interface | The IP address of this OSPF interface. |

## Show Commands

| <b>Label</b>    | <b>Description (Continued)</b>                                                                                                                                                                                                                                                                                                                                                                                |
|-----------------|---------------------------------------------------------------------------------------------------------------------------------------------------------------------------------------------------------------------------------------------------------------------------------------------------------------------------------------------------------------------------------------------------------------|
| IP Address      | The IP address and mask of this OSPF interface.                                                                                                                                                                                                                                                                                                                                                               |
| Interface Name  | The interface name.                                                                                                                                                                                                                                                                                                                                                                                           |
| Area Id         | A 32-bit integer uniquely identifying the area to which this interface is connected. Area ID 0.0.0.0 is used for the OSPF backbone.                                                                                                                                                                                                                                                                           |
| Priority        | The priority of this interface. Used in multi-access networks, this field is used in the designated router election algorithm.                                                                                                                                                                                                                                                                                |
| Hello Intrvl    | The length of time, in seconds, between the Hello packets that the router sends on the interface. This value must be the same for all routers attached to a common network.                                                                                                                                                                                                                                   |
| Rtr Dead Intrvl | The number of seconds that a router's Hello packets have not been seen before it's neighbors declare the router down. This should be some multiple of the Hello interval. This value must be the same for all routers attached to a common network.                                                                                                                                                           |
| Retrans Intrvl  | The number of seconds between link-state advertisement retransmissions, for adjacencies belonging to this interface. This value is also used when retransmitting database description and link-state request packets.                                                                                                                                                                                         |
| Poll Intrvl     | The larger time interval, in seconds, between the Hello packets sent to an inactive non-broadcast multi-access neighbor.                                                                                                                                                                                                                                                                                      |
| Metric          | The metric to be advertised for this interface.                                                                                                                                                                                                                                                                                                                                                               |
| Advert Subnet   | <b>False</b> – When a point-to-point interface is configured as false, then the subnet is not advertised and the endpoints are advertised as host routes.<br><b>True</b> – When a point-to-point interface is configured to true, then the subnet is advertised.                                                                                                                                              |
| Transit Delay   | The estimated number of seconds it takes to transmit a link state update packet over this interface.                                                                                                                                                                                                                                                                                                          |
| Auth Type       | Identifies the authentication procedure to be used for the packet.<br><b>None</b> – Routing exchanges over the network/subnet are not authenticated.<br><b>Simple</b> – A 64-bit field is configured on a per-network basis. All packets sent on a particular network must have this configured value in their OSPF header 64-bit authentication field. This essentially serves as a “clear” 64-bit password. |

| Label        | Description (Continued)                                                                                                                                                                                                                                                                                                                                                                                                                                                                                                                                                                                                                                                                                                                        |
|--------------|------------------------------------------------------------------------------------------------------------------------------------------------------------------------------------------------------------------------------------------------------------------------------------------------------------------------------------------------------------------------------------------------------------------------------------------------------------------------------------------------------------------------------------------------------------------------------------------------------------------------------------------------------------------------------------------------------------------------------------------------|
|              | MD5 – A shared secret key is configured in all routers attached to a common network/subnet. For each OSPF protocol packet, the key is used to generate/verify a “message digest” that is appended to the end of the OSPF packet.                                                                                                                                                                                                                                                                                                                                                                                                                                                                                                               |
| Passive      | <p>False – This interfaces operates as a normal OSPF interface with regard to adjacency forming and network/link behavior.</p> <p>True – no OSPF HELLOs will be sent out on this interface and the router advertises this interface as a stub network/link in its router LSAs.</p>                                                                                                                                                                                                                                                                                                                                                                                                                                                             |
| MTU          | The desired size of the largest packet which can be sent/received on this OSPF interface, specified in octets. This size DOES include the underlying IP header length, but not the underlying layer headers/trailers.                                                                                                                                                                                                                                                                                                                                                                                                                                                                                                                          |
| Admin Status | <p>Disabled – OSPF on this interface is administratively shut down.</p> <p>Enabled – OSPF on this interface is administratively enabled.</p>                                                                                                                                                                                                                                                                                                                                                                                                                                                                                                                                                                                                   |
| Oper State   | <p>Down – This is the initial interface state. In this state, the lower-level protocols have indicated that the interface is unusable.</p> <p>Waiting – The router is trying to determine the identity of the (Backup) Designated router for the network.</p> <p>Point To Point – The interface is operational, and connects either to a physical point-to-point network or to a virtual link.</p> <p>Designated Rtr – This router is the Designated Router for this network.</p> <p>Other Desig Rtr – The interface is operational and part of a broadcast or NBMA network on which another router has been selected to be the Designated Router.</p> <p>Backup Desig Rtr – This router is the Backup Designated Router for this network.</p> |
| DR-Id        | The IP Interface address of the router identified as the Designated Router for the network in which this interface is configured. Set to 0.0.0.0 if there is no Designated router                                                                                                                                                                                                                                                                                                                                                                                                                                                                                                                                                              |
| BDR-Id       | The IP Interface address of the router identified as the Backup Designated Router for the network in which this interface is configured. Set to 0.0.0.0 if there is no Backup Designated router.                                                                                                                                                                                                                                                                                                                                                                                                                                                                                                                                               |
| IF Type      | <p>Broadcast – LANs, such as Ethernet.</p> <p>NBMA – X.25, Frame Relay and similar technologies.</p>                                                                                                                                                                                                                                                                                                                                                                                                                                                                                                                                                                                                                                           |

| Label                       | Description (Continued)                                                                                                                                                                                                                                                                                                                                                                                                     |
|-----------------------------|-----------------------------------------------------------------------------------------------------------------------------------------------------------------------------------------------------------------------------------------------------------------------------------------------------------------------------------------------------------------------------------------------------------------------------|
|                             | <code>Point-To-Point</code> – Links that are definitively point to point.                                                                                                                                                                                                                                                                                                                                                   |
| <code>Network Type</code>   | <p><code>Stub</code> – OPSF has not established a neighbor relationship with any other OSPF router on this network as such only traffic sourced or destined to this network will be routed to this network.</p> <p><code>Transit</code> – OPSF has established at least one neighbor relationship with any other OSPF router on this network as such traffic en route to other networks may be routed via this network.</p> |
| <code>Oper MTU</code>       | The operational size of the largest packet which can be sent/received on this OSPF interface, specified in octets. This size DOES include the underlying IP header length, but not the underlying layer headers/trailers.                                                                                                                                                                                                   |
| <code>Last Enabled</code>   | The time that this interface was last enabled to run OSPF on this interface.                                                                                                                                                                                                                                                                                                                                                |
| <code>Nbr Count</code>      | The number of OSPF neighbors on the network for this interface.                                                                                                                                                                                                                                                                                                                                                             |
| <code>If Events</code>      | The number of times this OSPF interface has changed its state, or an error has occurred since this interface was last enabled.                                                                                                                                                                                                                                                                                              |
| <code>Tot Rx Packets</code> | The total number of OSPF packets received on this interface since this interface was last enabled.                                                                                                                                                                                                                                                                                                                          |
| <code>Tot Tx Packets</code> | The total number of OSPF packets transmitted on this interface since this interface was last enabled.                                                                                                                                                                                                                                                                                                                       |
| <code>Rx Hellos</code>      | The total number of OSPF Hello packets received on this interface since this interface was last enabled.                                                                                                                                                                                                                                                                                                                    |
| <code>Tx Hellos</code>      | The total number of OSPF Hello packets transmitted on this interface since this interface was last enabled.                                                                                                                                                                                                                                                                                                                 |
| <code>Rx DBDs</code>        | The total number of OSPF database description packets received on this interface since this interface was last enabled.                                                                                                                                                                                                                                                                                                     |
| <code>Tx DBDs</code>        | The total number of OSPF database description packets transmitted on this interface since this interface was last enabled.                                                                                                                                                                                                                                                                                                  |
| <code>Rx LSRs</code>        | The total number of Link State Requests (LSRs) received on this interface since this interface was last enabled.                                                                                                                                                                                                                                                                                                            |
| <code>Tx LSRs</code>        | The total number of Link State Requests (LSRs) transmitted on this interface since this interface was last enabled.                                                                                                                                                                                                                                                                                                         |
| <code>Rx LSUs</code>        | The total number of Link State Updates (LSUs) received on this interface since this interface was last enabled.                                                                                                                                                                                                                                                                                                             |
| <code>Tx LSUs</code>        | The total number of Link State Updates (LSUs) transmitted on this interface since this interface was last enabled.                                                                                                                                                                                                                                                                                                          |

| Label          | Description (Continued)                                                                                                                                                         |
|----------------|---------------------------------------------------------------------------------------------------------------------------------------------------------------------------------|
| Rx LS Acks     | The total number of Link State Acknowledgements received on this interface since this interface was last enabled.                                                               |
| Tx LS Acks     | The total number of Link State Acknowledgements transmitted on this interface since this interface was last enabled.                                                            |
| Retransmits    | The total number of OSPF Retransmits sent on this interface since this interface was last enabled.                                                                              |
| Discards       | The total number of OSPF packets discarded on this interface since this interface was last enabled.                                                                             |
| Bad Networks   | The total number of OSPF packets received with invalid network or mask since this interface was last enabled.                                                                   |
| Bad Virt Links | The total number of OSPF packets received on this interface that are destined to a virtual link that does not exist since this interface was last enabled.                      |
| Bad Areas      | The total number of OSPF packets received with an area mismatch since this interface was last enabled.                                                                          |
| Bad Dest Addr  | The total number of OSPF packets received with the incorrect IP destination address since this interface was last enabled.                                                      |
| Bad Auth Types | The total number of OSPF packets received with an invalid authorization type since this interface was last enabled.                                                             |
| Auth Failures  | The total number of OSPF packets received with an invalid authorization key since this interface was last enabled.                                                              |
| Bad Neighbors  | The total number of OSPF packets received where the neighbor information does not match the information this router has for the neighbor since this interface was last enabled. |
| Bad Pkt Types  | The total number of OSPF packets received with an invalid OSPF packet type since this interface was last enabled.                                                               |
| Bad Lengths    | The total number of OSPF packets received on this interface with a total length not equal to the length given in the packet itself since this interface was last enabled.       |
| Bad Hello int. | The total number of OSPF packets received where the hello interval given in packet was not equal to that configured on this interface since this interface was last enabled.    |
| Bad Dead Int.  | The total number of OSPF packets received where the dead interval given in the packet was not equal to that configured on this interface since this interface was last enabled. |

## Show Commands

| Label           | Description (Continued)                                                                                                                                                                                                                                  |
|-----------------|----------------------------------------------------------------------------------------------------------------------------------------------------------------------------------------------------------------------------------------------------------|
| Bad Options     | The total number of OSPF packets received with an option that does not match those configured for this interface or area since this interface was last enabled.                                                                                          |
| Bad Versions    | The total number of OSPF packets received with bad OSPF version numbers since this interface was last enabled.                                                                                                                                           |
| Te Metric       | Indicates the TE metric configured for this interface. This metric is flooded out in the TE metric sub-tlv in the OSPF TE LSAs. Depending on the configuration, either the TE metric value or the native OSPF metric value is used in CSPF computations. |
| Te State        | Indicates the MPLS interface TE status from OSPF standpoint.                                                                                                                                                                                             |
| Admin Groups    | Indicates the bit-map inherited from MPLS interface that identifies the admin groups to which this interface belongs.                                                                                                                                    |
| Ldp Sync        | Specifies whether the IGP-LDP synchronization feature is enabled or disabled on all interfaces participating in the OSPF routing protocol.                                                                                                               |
| Ldp Sync Wait   | Indicates the time to wait for the LDP adjacency to come up.                                                                                                                                                                                             |
| Ldp Timer State | Indicates the state of the LDP sync time left on the OSPF interface.                                                                                                                                                                                     |
| Ldp Tm Left     | Indicates the time left before OSPF reverts back to advertising normal metric for this interface.                                                                                                                                                        |

### Sample Output

```
*A:JC-NodeA# show router ospf interface area 1 detail
=====
OSPF Interfaces in Area (Detailed) : 1
=====
Interface : ip-10.10.1.1

IP Address : 10.10.1.1
Area Id : 0.0.0.1
Priority : 1
Hello Intrvl : 5 sec
Retrans Intrvl : 5 sec
Cfg Metric : 0
Transit Delay : 1
Passive : False
Admin Status : Enabled
Designated Rtr : 10.20.1.1
IF Type : Broadcast
Oper MTU : 1500
Oper Metric : 1000
Nbr Count : 0
Tot Rx Packets : 0
Rx Hellos : 0
Rx DBDs : 0
Rtr Dead Intrvl : 15 sec
Poll Intrvl : 120 sec
Advert Subnet : True
Auth Type : None
Cfg MTU : 0
Oper State : Designated Rtr
Backup Desig Rtr : 0.0.0.0
Network Type : Transit
Last Enabled : 04/11/2007 16:06:27
Bfd Enabled : No
If Events : 5
Tot Tx Packets : 1116
Tx Hellos : 1116
Tx DBDs : 0
```

```

Rx LSRs : 0 Tx LSRs : 0
Rx LSUs : 0 Tx LSUs : 0
Rx LS Acks : 0 Tx LS Acks : 0
Retransmits : 0 Discards : 0
Bad Networks : 0 Bad Virt Links : 0
Bad Areas : 0 Bad Dest Adrs : 0
Bad Auth Types : 0 Auth Failures : 0
Bad Neighbors : 0 Bad Pkt Types : 0
Bad Lengths : 0 Bad Hello Int. : 0
Bad Dead Int. : 0 Bad Options : 0
Bad Versions : 0 Bad Checksums : 0
LSA Count : 0 LSA Checksum : 0x0
TE Metric : 678

```

```

=====
*A:JC-NodeA#

```

## lfa-coverage

**Syntax** **lfa-coverage**

**Context** show>router>ospf

**Description** This command displays OSPF Loop-Free Alternate (LFA) next-hop information.

### Sample Output

```

*A:Dut-A# show router ospf lfa-coverage
=====
LFA coverage ospfv2 instance 0
=====
Area Node Prefix

0.0.0.0 4/4(100%) 8/8(100%)
=====
*A:Dut-A#

```

## neighbor

**Syntax** **neighbor** [*ip-int-name*] [*router-id*]

**Context** show>router>ospf  
show>router>ospf3

**Description** This command will display all neighbor information. To reduce the amount of output the user may opt to select the neighbors on a given interface by address or name.

The **detail** option produces a large amount of data. It is recommended to use **detail** only when requesting a specific neighbor.

## Show Commands

**Parameters** *ip-int-name* — Display neighbor information only for neighbors of the interface identified by the interface name

*router-id* — Display neighbor information for the neighbor identified by the the specified router ID.

**Output** **Standard OSPF Neighbor Output** — The following table describes the standard command output fields for an OSPF neighbor.

| Label       | Description                                                                                                                                                                                                                                                                                                                                                                                                                                                                                                                                                                                                                                                                                                                                                                                                                                                                                                                                                                                                                                                                                                                                                                                                                                                                                                                                                                                                                                                                     |
|-------------|---------------------------------------------------------------------------------------------------------------------------------------------------------------------------------------------------------------------------------------------------------------------------------------------------------------------------------------------------------------------------------------------------------------------------------------------------------------------------------------------------------------------------------------------------------------------------------------------------------------------------------------------------------------------------------------------------------------------------------------------------------------------------------------------------------------------------------------------------------------------------------------------------------------------------------------------------------------------------------------------------------------------------------------------------------------------------------------------------------------------------------------------------------------------------------------------------------------------------------------------------------------------------------------------------------------------------------------------------------------------------------------------------------------------------------------------------------------------------------|
| Nbr IP Addr | The IP address this neighbor is using in its IP Source Address. Note that, on addressless links, this will not be 0.0.0.0, but the address of another of the neighbor's interfaces.                                                                                                                                                                                                                                                                                                                                                                                                                                                                                                                                                                                                                                                                                                                                                                                                                                                                                                                                                                                                                                                                                                                                                                                                                                                                                             |
| Nbr Rtr Id  | A 32-bit integer uniquely identifying the neighboring router in the Autonomous System.                                                                                                                                                                                                                                                                                                                                                                                                                                                                                                                                                                                                                                                                                                                                                                                                                                                                                                                                                                                                                                                                                                                                                                                                                                                                                                                                                                                          |
| Nbr State   | <p>Down — This is the initial state of a neighbor conversation. It indicates that there has been no recent information received from the neighbor.</p> <p>Attempt — This state is only valid for neighbors attached to NBMA networks. It indicates that no recent information has been received from the neighbor, but that a more concerted effort should be made to contact the neighbor.</p> <p>Init — In this state, an Hello packet has recently been seen from the neighbor. However, bidirectional communication has not yet been established with the neighbor (i.e., the router itself did not appear in the neighbor's Hello packet).</p> <p>Two Way — In this state, communication between the two routers is bidirectional.</p> <p>ExchStart — This is the first step in creating an adjacency between the two neighboring routers. The goal of this step is to decide which router is the master, and to decide upon the initial Database Descriptor sequence number.</p> <p>Exchange — In this state the router is describing its entire link state database by sending Database Description packets to the neighbor.</p> <p>Loading — In this state, Link State Request packets are sent to the neighbor asking for the more recent LSAs that have been discovered (but not yet received) in the Exchange state.</p> <p>Full — In this state, the neighboring routers are fully adjacent. These adjacencies will now appear in router-LSAs and network-LSAs.</p> |
| Priority    | The priority of this neighbor in the designated router election algorithm. The value 0 signifies that the neighbor is not eligible to become the designated router on this particular network.                                                                                                                                                                                                                                                                                                                                                                                                                                                                                                                                                                                                                                                                                                                                                                                                                                                                                                                                                                                                                                                                                                                                                                                                                                                                                  |
| RetxQ Len   | The current length of the retransmission queue.                                                                                                                                                                                                                                                                                                                                                                                                                                                                                                                                                                                                                                                                                                                                                                                                                                                                                                                                                                                                                                                                                                                                                                                                                                                                                                                                                                                                                                 |



| Label            | Description (Continued)                                                                                                                               |
|------------------|-------------------------------------------------------------------------------------------------------------------------------------------------------|
| Dead Time        | The time until this neighbor is declared down, this timer is set to the dead router interval when a valid hello packet is received from the neighbor. |
| No. of Neighbors | The number of adjacent OSPF neighbors on this interface.                                                                                              |

### Sample Output

```
A:ALA-A# show router ospf 1 neighbor
=====
OSPF Neighbors
=====
Interface-Name Rtr Id State Pri RetxQ TTL

pc157-2/1 10.13.8.158 Full 1 0 37
pc157-2/2 10.13.7.165 Full 100 0 33
pc157-2/3 10.13.6.188 Full 1 0 38

No. of Neighbors: 3
=====
A:ALA-A#
```

**Detailed OSPF Neighbor Output** — The following table describes the detailed command output fields for an OSPF neighbor.

| Label            | Description                                                                                                                                                                                                                                                                                                                                                                             |
|------------------|-----------------------------------------------------------------------------------------------------------------------------------------------------------------------------------------------------------------------------------------------------------------------------------------------------------------------------------------------------------------------------------------|
| Neighbor IP Addr | The IP address this neighbor is using in its IP source address. Note that, on addressless links, this will not be 0.0.0.0, but the address of another of the neighbor's interfaces.                                                                                                                                                                                                     |
| Local IF IP Addr | The IP address of this OSPF interface.                                                                                                                                                                                                                                                                                                                                                  |
| Area Id          | A 32-bit integer uniquely identifying the area to which this interface is connected. Area ID 0.0.0.0 is used for the OSPF backbone                                                                                                                                                                                                                                                      |
| Designated Rtr   | The IP Interface address of the router identified as the Designated Router for the network in which this interface is configured. Set to 0.0.0.0 if there is no Designated router.                                                                                                                                                                                                      |
| Neighbor Rtr Id  | A 32-bit integer uniquely identifying the neighboring router in the AS.                                                                                                                                                                                                                                                                                                                 |
| Neighbor State   | Down — This is the initial state of a neighbor conversation. It indicates that there has been no recent information received from the neighbor<br><br>Attempt — This state is only valid for neighbors attached to NBMA networks. It indicates that no recent information has been received from the neighbor, but that a more concerted effort should be made to contact the neighbor. |

## Show Commands

| Label                         | Description (Continued)                                                                                                                                                                                                                                                                                                                                                                                                                                                                                                                                                                                                                                                                                                                                                                                                                                                                                                                                                                                                                                                                                                                                           |
|-------------------------------|-------------------------------------------------------------------------------------------------------------------------------------------------------------------------------------------------------------------------------------------------------------------------------------------------------------------------------------------------------------------------------------------------------------------------------------------------------------------------------------------------------------------------------------------------------------------------------------------------------------------------------------------------------------------------------------------------------------------------------------------------------------------------------------------------------------------------------------------------------------------------------------------------------------------------------------------------------------------------------------------------------------------------------------------------------------------------------------------------------------------------------------------------------------------|
|                               | <p><code>Init</code> – In this state, an Hello packet has recently been seen from the neighbor. However, bidirectional communication has not yet been established with the neighbor (i.e., the router itself did not appear in the neighbor's Hello packet).</p> <p><code>Two Way</code> – In this state, communication between the two routers is bidirectional.</p> <p><code>Exchange start</code> – This is the first step in creating an adjacency between the two neighboring routers. The goal of this step is to decide which router is the master, and to decide upon the initial Database Descriptor sequence number.</p> <p><code>Exchange</code> – In this state the router is describing its entire link state database by sending Database Description packets to the neighbor</p> <p><code>Loading</code> – In this state, Link State Request packets are sent to the neighbor asking for the more recent LSAs that have been discovered (but not yet received) in the Exchange state.</p> <p><code>Full</code> – In this state, the neighboring routers are fully adjacent. These adjacencies will now appear in router-LSAs and network-LSAs.</p> |
| <code>Priority</code>         | The priority of this neighbor in the designated router election algorithm. The value 0 signifies that the neighbor is not eligible to become the designated router on this particular network.                                                                                                                                                                                                                                                                                                                                                                                                                                                                                                                                                                                                                                                                                                                                                                                                                                                                                                                                                                    |
| <code>Retrans Q Length</code> | The current length of the retransmission queue.                                                                                                                                                                                                                                                                                                                                                                                                                                                                                                                                                                                                                                                                                                                                                                                                                                                                                                                                                                                                                                                                                                                   |
| <code>Options</code>          | <p><code>E</code> – External Routes Support</p> <p><code>MC</code> – Multicast Support</p> <p><code>N/P</code> – Type 7 LSA Support</p> <p><code>EA</code> – External Attribute LSA Support</p> <p><code>DC</code> – Demand Circuit Support</p> <p><code>O</code> – Opaque LSA Support</p>                                                                                                                                                                                                                                                                                                                                                                                                                                                                                                                                                                                                                                                                                                                                                                                                                                                                        |
| <code>Backup Desig Rtr</code> | The IP Interface address of the router identified as the Backup Designated Router for the network in which this interface is configured. Set to 0.0.0.0 if there is no backup designated router.                                                                                                                                                                                                                                                                                                                                                                                                                                                                                                                                                                                                                                                                                                                                                                                                                                                                                                                                                                  |
| <code>Events</code>           | The number of times this neighbor relationship has changed state, or an error has occurred.                                                                                                                                                                                                                                                                                                                                                                                                                                                                                                                                                                                                                                                                                                                                                                                                                                                                                                                                                                                                                                                                       |
| <code>Last Event Time</code>  | The time when the last event occurred that affected the adjacency to the neighbor.                                                                                                                                                                                                                                                                                                                                                                                                                                                                                                                                                                                                                                                                                                                                                                                                                                                                                                                                                                                                                                                                                |

| Label             | Description (Continued)                                                                                                                                                                  |
|-------------------|------------------------------------------------------------------------------------------------------------------------------------------------------------------------------------------|
| Up Time           | This value represents the uninterrupted time, in hundredths of seconds, the adjacency to this neighbor has been up. To evaluate when the last state change occurred see last event time. |
| Time Before Dead  | The time until this neighbor is declared down, this timer is set to the dead router interval when a valid hello packet is received from the neighbor.                                    |
| Bad Nbr States    | The total number of OSPF packets received when the neighbor state was not expecting to receive this packet type since this interface was last enabled.                                   |
| LSA Inst fails    | The total number of times an LSA could not be installed into the LSDB due to a resource allocation issue since this interface was last enabled.                                          |
| Bad Seq Nums      | The total number of times when a database description packet was received with a sequence number mismatch since this interface was last enabled.                                         |
| Bad MTUs          | The total number of times when the MTU in a received database description packet was larger than the MTU of the receiving interface since this interface was last enabled.               |
| Bad Packets       | The total number of times when an LS update was received with an illegal LS type or an option mismatch since this interface was last enabled.                                            |
| LSA not in LSDB   | The total number of times when an LS request was received for an LSA not installed in the LSDB of this router since this interface was last enabled.                                     |
| Option Mismatches | The total number of times when a LS update was received with an option mismatch since this interface was last enabled.                                                                   |
| Nbr Duplicates    | The total number of times when a duplicate database description packet was received during the exchange state since this interface was last enabled.                                     |

### Sample Output

```
A:ALA-A# show router ospf neighbor detail
=====
OSPF Neighbors

Neighbor Rtr Id : 10.13.8.158 Interface: pc157-2/1

Neighbor IP Addr : 10.16.1.8
Local IF IP Addr : 10.16.1.7
Area Id : 0.0.0.0
Designated Rtr : 0.0.0.0 Backup Desig Rtr : 0.0.0.0
Neighbor State : Full Priority : 1
```

## Show Commands

```
Retrans Q Length : 0 Options : -E--O-
Events : 4 Last Event Time : 05/06/2006 00:11:16
Up Time : 1d 18:20:20 Time Before Dead : 38 sec
GR Helper : Not Helping GR Helper Age : 0 sec
GR Exit Reason : None GR Restart Reason: Unknown
Bad Nbr States : 1 LSA Inst fails : 0
Bad Seq Num : 0 Bad MTUs : 0
Bad Packets : 0 LSA not in LSDB : 0
Option Mismatches: 0 Nbr Duplicates : 0
Num Restarts : 0 Last Restart at : Never
```

```

Neighbor Rtr Id : 10.13.7.165 Interface: pc157-2/2

```

```
Neighbor IP Addr : 10.12.1.3
Local IF IP Addr : 10.12.1.7
Area Id : 0.0.0.0
Designated Rtr : 10.13.9.157 Backup Desig Rtr : 10.13.7.165
Neighbor State : Full Priority : 100
Retrans Q Length : 0 Options : -E--O-
Events : 4 Last Event Time : 05/05/2006 01:39:13
Up Time : 0d 16:52:27 Time Before Dead : 33 sec
GR Helper : Not Helping GR Helper Age : 0 sec
GR Exit Reason : None GR Restart Reason: Unknown
Bad Nbr States : 0 LSA Inst fails : 0
Bad Seq Num : 0 Bad MTUs : 0
Bad Packets : 0 LSA not in LSDB : 0
Option Mismatches: 0 Nbr Duplicates : 0
Num Restarts : 0 Last Restart at : Never
```

```

Neighbor Rtr Id : 10.13.6.188 Interface: pc157-2/3

```

```
Neighbor IP Addr : 10.14.1.4
Local IF IP Addr : 10.14.1.7
Area Id : 0.0.0.0
Designated Rtr : 10.13.9.157 Backup Desig Rtr : 10.13.6.188
Neighbor State : Full Priority : 1
Retrans Q Length : 0 Options : -E--O-
Events : 4 Last Event Time : 05/05/2006 08:35:18
Up Time : 0d 09:56:25 Time Before Dead : 38 sec
GR Helper : Not Helping GR Helper Age : 0 sec
GR Exit Reason : None GR Restart Reason: Unknown
Bad Nbr States : 1 LSA Inst fails : 0
Bad Seq Num : 0 Bad MTUs : 0
Bad Packets : 0 LSA not in LSDB : 0
Option Mismatches: 0 Nbr Duplicates : 0
Num Restarts : 0 Last Restart at : Never
```

```
=====
A:ALA-A#
```

## opaque-database

**Syntax** `opaque-database [link link-id | area area-id] [as] [adv-router router-id] [ls-id] [detail]`

**Context** `show>router>ospf`

**Description** This command displays OSPF opaque database information.

**Output OSPF Opaque Database Output** — The following table describes the OSPF opaque database output fields.

| Label         | Description                                                                                                                                                                         |
|---------------|-------------------------------------------------------------------------------------------------------------------------------------------------------------------------------------|
| Area Id       | A 32-bit integer uniquely identifying an area. Area ID 0.0.0.0 is used for the OSPF backbone.                                                                                       |
| Type          | NSSA — This area is configured as a NSSA area.<br>Area — This area is configured as a standard area (not NSSA or stub).<br>Stub — This area is configured as a NSSA area.           |
| Link State Id | The link state ID is an LSA type specific field containing either a Router-Id or an IP Address; it identifies the piece of the routing domain being described by the advertisement. |
| Adv Rtr Id    | The router identifier of the router advertising the LSA.                                                                                                                            |
| Age           | The age of the link state advertisement in seconds.                                                                                                                                 |
| Sequence      | The signed 32-bit integer sequence number.                                                                                                                                          |
| Cksum         | The 32-bit unsigned sum of the link-state advertisements' LS checksums.                                                                                                             |

### Sample Output

```
A:ALA-A# show router ospf opaque-database
=====
OSPF Opaque Link State Database (Type : All)
=====
Area Id Type Link State Id Adv Rtr Id Age Sequence Cksum

0.0.0.0 Area 1.0.0.1 180.0.0.2 205 0x8000007e 0xb1b2
0.0.0.0 Area 1.0.0.1 180.0.0.5 617 0x80000084 0xb1a6
0.0.0.0 Area 1.0.0.1 180.0.0.8 1635 0x80000081 0xc391
0.0.0.0 Area 1.0.0.1 180.0.0.9 1306 0x80000082 0xc58c
0.0.0.0 Area 1.0.0.1 180.0.0.10 53 0x80000082 0xc986
0.0.0.0 Area 1.0.0.1 180.0.0.11 577 0x8000007e 0xd57c
0.0.0.0 Area 1.0.0.1 180.0.0.12 1628 0x80000080 0xd578
0.0.0.0 Area 1.0.0.1 180.0.0.13 581 0x80000080 0xd972
0.0.0.0 Area 1.0.0.1 180.0.0.22 1006 0x80000080 0xfd3c
0.0.0.0 Area 1.0.0.1 180.0.0.23 1238 0x80000083 0xfb39
0.0.0.0 Area 1.0.0.1 180.0.0.27 55 0x80000083 0xc21
0.0.0.0 Area 1.0.0.1 180.0.0.28 389 0x80000083 0x101b
0.0.0.0 Area 1.0.0.1 180.0.0.29 1658 0x80000082 0x1614
0.0.0.0 Area 1.0.0.1 180.0.0.30 976 0x80000083 0x180f
0.0.0.0 Area 1.0.0.2 180.0.0.2 45 0x800000a0 0x2f60
0.0.0.0 Area 1.0.0.2 180.0.0.5 1357 0x80000084 0x7038
0.0.0.0 Area 1.0.0.2 180.0.0.8 1960 0x80000084 0x3472
...

No. of Opaque LSAs: 88
```

## Show Commands

```
=====
A:ALA-A#

*A:Dut-A# show router ospf opaque-database adv-router 10.20.1.1 detail
=====
OSPF Opaque Link State Database (Type : All) (Detailed)
=====

Opaque LSA

Area Id : 0.0.0.0 Adv Router Id : 10.20.1.1
Link State Id : 1.0.0.1 LSA Type : Area Opaque
Sequence No : 0x80000028 Checksum : 0xb136
Age : 192 Length : 28
Options : E
Advertisement :
 ROUTER-ID TLV (0001) Len 4 : 10.20.1.1

Opaque LSA

Area Id : 0.0.0.0 Adv Router Id : 10.20.1.1
Link State Id : 1.0.0.2 LSA Type : Area Opaque
Sequence No : 0x8000000d Checksum : 0x17f3
Age : 678 Length : 164
Options : E
Advertisement :
 LINK INFO TLV (0002) Len 140 :
 Sub-TLV: 1 Len: 1 LINK_TYPE : 2
 Sub-TLV: 2 Len: 4 LINK_ID : 10.10.1.2
 Sub-TLV: 3 Len: 4 LOC_IP_ADDR : 10.10.1.1
 Sub-TLV: 4 Len: 4 REM_IP_ADDR : 0.0.0.0
 Sub-TLV: 5 Len: 4 TE_METRIC : 1000
 Sub-TLV: 6 Len: 4 MAX_BDWTH : 100000 Kbps
 Sub-TLV: 7 Len: 4 RSRVBL_BDWTH : 800000 Kbps
 Sub-TLV: 8 Len: 32 UNRSRVD_CLS0 :
 P0: 80000 Kbps P1: 320000 Kbps P2: 320000 Kbps P3: 320000 Kbps
 P4: 400000 Kbps P5: 400000 Kbps P6: 400000 Kbps P7: 80000 Kbps
 Sub-TLV: 9 Len: 4 ADMIN_GROUP : 0 None
 Sub-TLV: 17 Len: 36 TELK_BW_CONST:
 BW Model : MAM
 BC0: 80000 Kbps BC1: 0 Kbps BC2: 320000 Kbps BC3: 0 Kbps
 BC4: 0 Kbps BC5: 400000 Kbps BC6: 0 Kbps BC7: 0 Kbps

*A:Dut-A#
```

## range

**Syntax** `range [area-id]`

**Context** `show>router>ospf`  
`show>router>ospf3`

**Description** This command displays ranges of addresses on an Area Border Router (ABR) for the purpose of route summarization or suppression.

**Parameters** *area-id* — Display the configured ranges for the specified area.

**Output** **OSPF Range Output** — The following table describes the OSPF range output fields.

| Label        | Description                                                                                                                                                                                                                                                                                                                                            |
|--------------|--------------------------------------------------------------------------------------------------------------------------------------------------------------------------------------------------------------------------------------------------------------------------------------------------------------------------------------------------------|
| Area Id      | A 32-bit integer uniquely identifying an area. Area ID 0.0.0.0 is used for the OSPF backbone.                                                                                                                                                                                                                                                          |
| Address/Mask | The mask for the range expressed as a decimal integer mask length or in dotted decimal notation.                                                                                                                                                                                                                                                       |
| Advertise    | False — The specified address/mask is not advertised outside the area.<br><br>True — The specified address/mask is advertised outside the area.                                                                                                                                                                                                        |
| LSDb Type    | NSSA — This range was specified in the NSSA context, and specifies that the range applies to external routes (via type-7 LSAs) learned within the NSSA when the routes are advertised to other areas as type-5 LSAs.<br><br>Summary — This range was not specified in the NSSA context, the range applies to summary LSAs even if the area is an NSSA. |

### Sample Output

```
A:ALA-A# show router ospf 1 range
=====
OSPF Ranges
=====
Area Id Address/Mask Advertise LSDb Type

No. of Ranges: 0
=====
A:ALA-A#
```

```
A:ALA-A# show router ospf range 180.0.7.9
=====
OSPF Ranges for Area Id : 180.0.7.9
=====
Area Id Address/Mask Advertise LSDb Type

No. of Ranges: 0
```

## Show Commands

```
=====
A:ALA-A#
```

### routes

**Syntax** `routes [ip-prefix[/prefix-length]] [type] [detail] [alternative] [summary]`

**Context** `show>router>ospf`

**Description** This command information about OSPF routes.

**Parameters** `ip-prefix[/prefix-length]` — Displays information about the specified IP prefix and length.

`type` — Displays information about the specified type.

**Values** `intra-area, inter-area, external-1, external-2, nssa-1, nssa-2`

`detail` — Displays detailed information about the routes.

`alternative` — Displays the level of protection per prefix (ref. show router isis routes alternative)

`summary` — Displays summarized information about the routes.

### Sample Output

```
*A:Dut-A# show router ospf routes alternative detail
=====
OSPFv2 Routing Table (detailed)
=====
Destination Type(Dest) Stat
 NHIP NHIF Cost[E2] Area Tunnel-Information
 A-NHIP(L) A-NHIF A-Cost[E2] A-Type PGID

1.1.2.0/24 IA (NET) D (F)
 DIRECT 2 10 0.0.0.0
1.1.3.0/24 IA (NET) D (F)
 DIRECT 3 10 0.0.0.0
1.2.3.0/24 IA (NET) N (R)
 1.1.2.2 2 20 0.0.0.0
 1.1.3.3 3 20 0.0.0.0
1.2.4.0/24 IA (NET) N (R)
 1.1.2.2 2 20 0.0.0.0
 1.1.3.3(L) 3 30 LINK 0x130015
1.3.5.0/24 IA (NET) N (R)
 1.1.3.3 3 20 0.0.0.0
 1.1.2.2(L) 2 30 LINK 0x130016
1.4.5.0/24 IA (NET) N (R)
 1.1.2.2 2 30 0.0.0.0
 1.1.3.3 3 30 0.0.0.0
1.4.6.0/24 IA (NET) N (R)
 1.1.2.2 2 30 0.0.0.0
 1.1.3.3(L) 3 40 LINK 0x130015
1.5.6.0/24 IA (NET) N (R)
 1.1.3.3 3 30 0.0.0.0
 1.1.2.2(L) 2 40 LINK 0x130016
10.20.1.1/32 IA (HOST) D (F)
```



```

DIRECT 1 0 0.0.0.0
10.20.1.2/32 IA (HOST) N (R)
 1.1.2.2 2 10 0.0.0.0
 1.1.3.3(L) 3 20 LINK 0x130015
10.20.1.3/32 IA (HOST) N (R)
 1.1.3.3 3 10 0.0.0.0
 1.1.2.2(L) 2 20 LINK 0x130016
10.20.1.4/32 IA (HOST) N (R)
 1.1.2.2 2 20 0.0.0.0
 1.1.3.3(L) 3 30 LINK 0x130015
10.20.1.5/32 IA (HOST) N (R)
 1.1.3.3 3 20 0.0.0.0
 1.1.2.2(L) 2 30 LINK 0x130016
10.20.1.6/32 IA (HOST) N (R)
 1.1.3.3 3 30 0.0.0.0
 1.1.2.2 2 30 0.0.0.0

10.20.1.2/0 IA (RTR) N (N)
 1.1.2.2 2 10 0.0.0.0
10.20.1.3/0 IA (RTR) N (N)
 1.1.3.3 3 10 0.0.0.0
10.20.1.4/0 IA (RTR) N (N)
 1.1.2.2 2 20 0.0.0.0
10.20.1.5/0 IA (RTR) N (N)
 1.1.3.3 3 20 0.0.0.0
10.20.1.6/0 IA (RTR) N (N)
 1.1.3.3 3 30 0.0.0.0
 1.1.2.2 2 30 0.0.0.0

```

```

19 OSPFv2 routes found (23 paths)
```

```
Flags: L = Loop-Free Alternate nexthop
```

```
=====
*A:Dut-A#
```

## Show Commands

### spf

**Syntax** `spf [lfa]`

**Context** `show>router>ospf`  
`show>router>ospf3`

**Description** This command displays statistics of shortest-path-first (SPF) calculations.

**Parameters** `lfa` — Displays Loop-Free Alternate (LFA) next-hop information.

**Output** **SPF Output Fields** — The following table describes SPF output fields.

| Label                     | Description                                                                                                                                                                                                                                                                                                                                           |
|---------------------------|-------------------------------------------------------------------------------------------------------------------------------------------------------------------------------------------------------------------------------------------------------------------------------------------------------------------------------------------------------|
| Total SPF Runs            | The total number of incremental SPF runs triggered by new or updated LSAs.                                                                                                                                                                                                                                                                            |
| Last Full SPF run @       | The date and time when the external OSPF Dijkstra (SPF) was last run.                                                                                                                                                                                                                                                                                 |
| Last Full SPF Time        | The length of time, in seconds, when the last full SPF was run.                                                                                                                                                                                                                                                                                       |
| Intra SPF Time            | The time when intra-area SPF was last run on this area.                                                                                                                                                                                                                                                                                               |
| Inter SPF Time            | The total number of incremental SPF runs triggered by new or updated type-3 and type-4 summary LSAs.                                                                                                                                                                                                                                                  |
| Extern SPF Time           | The total number of incremental SPF runs triggered by new or updated type-5 external LSAs.                                                                                                                                                                                                                                                            |
| RTM Updt Time             | The time, in hundredths of seconds, used to perform a total SPF calculation.                                                                                                                                                                                                                                                                          |
| Min/Avg/Max Full SPF Time | <code>Min</code> — The minimum time, in hundredths of seconds, used to perform a total SPF calculation.<br><code>Avg</code> — The average time, in hundredths of seconds, of all the total SPF calculations performed by this OSPF router.<br><code>Max</code> — The maximum time, in hundredths of seconds, used to perform a total SPF calculation. |
| Total Sum Incr SPF Runs   | The total number of incremental SPF runs triggered by new or updated type-3 and type-4 summary LSAs.                                                                                                                                                                                                                                                  |
| Total Ext Incr SPF Runs   | The total number of incremental SPF runs triggered by new or updated type-5 external LSAs.                                                                                                                                                                                                                                                            |

### Sample Output

```
A:Dut-A# show router ospf spf lfa
=====
OSPF SPF Statistics
=====
Total SPF Runs : 6
Last Full SPF run @ : 02/20/2012 09:19:35
```

```

Last Full SPF Time : < 0.01 secs
 Intra SPF Time : < 0.01 secs
 Inter SPF Time : < 0.01 secs
 Extern SPF Time : < 0.01 secs
 RTM Updt Time : < 0.01 secs

```

```

Min/Avg/Max Full SPF Times : 0.00/0.00/0.00 secs
Min/Avg/Max RTM Updt Times : 0.00/0.00/0.00 secs

```

```
Total Sum Incr SPF Runs : 0
```

```
Total Ext Incr SPF Runs : 0
```

```

Total LFA SPF Runs : 5
Last LFA SPF run @ : 02/20/2012 09:19:35
Last LFA SPF Time : < 0.01 secs
Min/Avg/Max LFA SPF Times : 0.00/0.00/0.00 secs

```

```
=====
A:Dut-A#
```

```
A:ALA-A# show router ospf 1 spf
```

```
=====
OSPF SPF Statistics
=====
```

```

Total SPF Runs : 109
Last Full SPF run @ : 11/07/2006 18:43:07
Last Full SPF Time : < 0.01 secs
 Intra SPF Time : < 0.01 secs
 Inter SPF Time : < 0.01 secs
 Extern SPF Time : < 0.01 secs
 RTM Updt Time : < 0.01 secs

```

```

Min/Avg/Max Full SPF Times : 0.02/0.00/0.06 secs
Min/Avg/Max RTM Updt Times : 0.02/0.00/0.06 secs

```

```

Total Sum Incr SPF Runs : 333
Last Sum Incr SPF run @ : 11/07/2006 18:43:09
Last Sum Incr Calc Time : < 0.01 secs

```

```
Total Ext Incr SPF Runs : 0
```

```
=====
A:ALA-A#
```

## Show Commands

### statistics

**Syntax** `statistics`

**Context** `show>router>ospf`  
`show>router>ospf3`

**Description** This command displays the global OSPF statistics.

**Output** **OSPF Statistics Output Fields** — The following table describes the command output fields for OSPF statistics.

| Label          | Description                                                                                          |
|----------------|------------------------------------------------------------------------------------------------------|
| Rx Packets     | The total number of OSPF packets received on all OSPF enabled interfaces.                            |
| Tx Packets     | The total number of OSPF packets transmitted on all OSPF enabled interfaces.                         |
| Rx Hellos      | The total number of OSPF Hello packets received on all OSPF enabled interfaces.                      |
| Tx Hellos      | The total number of OSPF Hello packets transmitted on all OSPF enabled interfaces.                   |
| Rx DBDs        | The total number of OSPF database description packets received on all OSPF enabled interfaces.       |
| Tx DBDs        | The total number of OSPF database description packets transmitted on all OSPF enabled interfaces     |
| Rx LSRs        | The total number of OSPF Link State Requests (LSRs) received on all OSPF enabled interfaces.         |
| Tx LSRs        | The total number of OSPF Link State Requests (LSRs) transmitted on all OSPF enabled interfaces.      |
| Rx LSUs        | The total number of OSPF Link State Update (LSUs) received on all OSPF enabled interfaces.           |
| Tx LSUs        | The total number of OSPF Link State Update (LSUs) transmitted on all OSPF enabled interfaces.        |
| Rx LS Acks     | The total number of OSPF Link State Acknowledgements (LSAs) received on all OSPF enabled interfaces. |
| New LSAs Recvd | The total number of new OSPF Link State Advertisements received on all OSPF enabled interfaces.      |
| New LSAs Orig  | The total number of new OSPF Link State Advertisements originated on all OSPF enabled interfaces.    |
| Ext LSAs Count | The total number of OSPF External Link State Advertisements.                                         |

| <b>Label</b>   | <b>Description</b>                                                                                                                                                                  |
|----------------|-------------------------------------------------------------------------------------------------------------------------------------------------------------------------------------|
| No of Areas    | The number of areas configured for this OSPF instance.                                                                                                                              |
| Total SPF Runs | The total number of incremental SPF runs triggered by new or updated LSAs.                                                                                                          |
| Ext SPF Runs   | The total number of incremental SPF runs triggered by new or updated type-5 external LSAs.                                                                                          |
| Retransmits    | The total number of OSPF Retransmits transmitted on all OSPF enabled interfaces.                                                                                                    |
| Discards       | The total number of OSPF packets discarded on all OSPF enabled interfaces.                                                                                                          |
| Bad Networks   | The total number of OSPF packets received on all OSPF enabled interfaces with invalid network or mask.                                                                              |
| Bad Virt Links | The total number of OSPF packets received on all OSPF enabled interfaces that are destined to a virtual link that does not exist.                                                   |
| Bad Areas      | The total number of OSPF packets received on all OSPF enabled interfaces with an area mismatch                                                                                      |
| Bad Dest Addr  | The total number of OSPF packets received on all OSPF enabled interfaces with the incorrect IP destination address.                                                                 |
| Bad Auth Types | The total number of OSPF packets received on all OSPF enabled interfaces with an invalid authorization type.                                                                        |
| Auth Failures  | The total number of OSPF packets received on all OSPF enabled interfaces with an invalid authorization key.                                                                         |
| Bad Neighbors  | The total number of OSPF packets received on all OSPF enabled interfaces where the neighbor information does not match the information this router has for the neighbor.            |
| Bad Pkt Types  | The total number of OSPF packets received on all OSPF enabled interfaces with an invalid OSPF packet type.                                                                          |
| Bad Lengths    | The total number of OSPF packets received on all OSPF enabled interfaces with a total length not equal to the length given in the packet itself.                                    |
| Bad Hello Int. | The total number of OSPF packets received on all OSPF enabled interfaces where the hello interval given in packet was not equal to that configured for the respective interface.    |
| Bad Dead Int.  | The total number of OSPF packets received on all OSPF enabled interfaces where the dead interval given in the packet was not equal to that configured for the respective interface. |

## Show Commands

| Label        | Description                                                                                                                                                        |
|--------------|--------------------------------------------------------------------------------------------------------------------------------------------------------------------|
| Bad Options  | The total number of OSPF packets received on all OSPF enabled interfaces with an option that does not match those configured for the respective interface or area. |
| Bad Versions | The total number of OSPF packets received on all OSPF enabled interfaces with bad OSPF version numbers.                                                            |

### Sample Output

```
A:ALA-A# show router ospf 1 statistics
=====
OSPF Statistics
=====
Rx Packets : 308462 Tx Packets : 246800
Rx Hellos : 173796 Tx Hellos : 149062
Rx DBDs : 67 Tx DBDs : 48
Rx LSRs : 21 Tx LSRs : 19
Rx LSUs : 105672 Tx LSUs : 65530
Rx LS Acks : 28906 Tx LS Acks : 32141
New LSAs Recvd : 38113 New LSAs Orig : 21067
Ext LSAs Count : 17 No of Areas : 3
Total SPF Runs : 327 Ext SPF Runs : 0
Retransmits : 46 Discards : 0
Bad Networks : 0 Bad Virt Links : 0
Bad Areas : 0 Bad Dest Addrs : 0
Bad Auth Types : 0 Auth Failures : 0
Bad Neighbors : 0 Bad Pkt Types : 0
Bad Lengths : 0 Bad Hello Int. : 0
Bad Dead Int. : 0 Bad Options : 0
Bad Versions : 0 Bad Checksums : 0
Failed SPF Attempts: 0
CSPF Requests : 0 CSPF Request Drops : 0
CSPF Path Found : 0 CSPF Path Not Found: 0
=====
A:ALA-A#
```

## status

**Syntax** `status`**Context**  
`show>router>ospf`  
`show>router>ospf3`**Description** Displays the general status of OSPF.**Output** **OSPF Status Output Fields** — The following table describes the command output fields for OSPF status.

| Label                      | Description                                                                                                                                                                                                   |
|----------------------------|---------------------------------------------------------------------------------------------------------------------------------------------------------------------------------------------------------------|
| OSPF Router Id             | A 32-bit integer uniquely identifying the router in the Autonomous System. The 7750 SR-Series defaults to the System IP address or if not configured the 32 least significant bits of the system MAC address. |
| OSPF Version               | The current version number of the OSPF protocol is 2.                                                                                                                                                         |
| OSPF Admin Status          | Disabled — Denotes that the OSPF process is disabled on all interfaces.<br>Enabled — Denotes that the OSPF process is active on at least one interface.                                                       |
| OSPF Oper Status           | Disabled — Denotes that the OSPF process is not operational on all interfaces.<br>Enabled — Denotes that the OSPF process is operational on at least one interface.                                           |
| Preference                 | The route preference for OSPF internal routes.                                                                                                                                                                |
| External Preference        | The route preference for OSPF external routes.                                                                                                                                                                |
| Backbone Router            | False — This variable indicates that this router is not configured as an OSPF back bone router.<br>True — This variable indicates that this router is configured as an OSPF back bone router.                 |
| Area Border Router         | False — This router is not an area border router.<br>True — This router is an area border router.                                                                                                             |
| AS Border Router           | False — This router is not configured as an Autonomous System border router.<br>True — This router is configured as an Autonomous System border router.                                                       |
| OSPF Ldp Sync Admin Status | Indicates whether the IGP-LDP synchronization feature is enabled or disabled on all interfaces participating in the OSPF routing protocol.                                                                    |

## Show Commands

### Sample Output

```
A:SetupCLI# show router ospf status
=====
OSPF Status
=====
OSPF Cfg Router Id : 255.255.255.255
OSPF Oper Router Id : 10.20.30.40
OSPF Version : 2
OSPF Admin Status : Enabled
OSPF Oper Status : Enabled
Graceful Restart : Disabled
GR Helper Mode : Disabled
Preference : 11
External Preference : 150
Backbone Router : True
Area Border Router : False
AS Border Router : True
Opaque LSA Support : True
Traffic Engineering Support : True
RFC 1583 Compatible : True
Demand Exts Support : False
In Overload State : True (Indefinitely in overload)
In External Overflow State : False
Exit Overflow Interval : 0
Last Overflow Entered : Never
Last Overflow Exit : 10/01/2011 07:34:03
External LSA Limit : -1
Reference Bandwidth : 10,000 Kbps
Init SPF Delay : 10000 msec
Sec SPF Delay : 10000 msec
Max SPF Delay : 12000 msec
Min LS Arrival Interval : 600000 msec
Init LSA Gen Delay : 100 msec
Sec LSA Gen Delay : 400 msec
Max LSA Gen Delay : 600000 msec
Last Ext SPF Run : Never
Ext LSA Cksum Sum : 0x0
OSPF Last Enabled : 10/01/2011 07:34:03
Multicast Import : False
Export Policies : test 567890123456789012345678901
 : test 567890123456789012345678902
 : test 567890123456789012345678903
 : test 567890123456789012345678904
 : test 567890123456789012345678905

Import Policies : test 567890123456789012345678901
 : test 567890123456789012345678902
 : test 567890123456789012345678903
 : test 567890123456789012345678904
 : test 567890123456789012345678905

OSPF Ldp Sync Admin Status : Disabled
LDP-over-RSVP : Enabled
RSVP-Shortcut : Enabled
Advertise-Tunnel-Link : Enabled
LFA : Enabled
Export Limit : 0
Export Limit Log Percent : 0
Total Exp Routes : 0
=====
```



A:SetupCLI#

A:ALA-A# **show router ospf 1 status**

=====  
 OSPF Status  
 =====

```

OSPF Router Id : 10.13.7.165
OSPF Version : 2
OSPF Admin Status : Enabled
OSPF Oper Status : Enabled
Graceful Restart : Enabled
GR Helper Mode : Disabled
Preference : 10
External Preference : 150
Backbone Router : True
Area Border Router : True
AS Border Router : True
Opaque LSA Support : True
Traffic Engineering Support : True
RFC 1583 Compatible : True
TOS Routing Support : False
Demand Exts Support : False
In Overload State : False
In External Overflow State : False
Exit Overflow Interval : 0
Last Overflow Entered : Never
Last Overflow Exit : Never
External LSA Limit : -1
Reference Bandwidth : 100,000,000 Kbps
Init SPF Delay : 500 msec
Sec SPF Delay : 2000 msec
Max SPF Delay : 15000 msec
Min LS Arrival Interval : 500 msec
Max LSA Gen Delay : 5000 msec
Last Ext SPF Run : Never
Ext LSA Cksum Sum : 0x2afce
OSPF Last Enabled : 05/23/2006 23:34:36
Export Policies : export-static

```

=====  
 A:ALA-A#

virtual-link

**Syntax** `virtual-link [detail]`

**Context** `show>router>ospf`  
`show>router>ospf3`

**Description** This command displays information for OSPF virtual links.

**Parameters** **detail** — Provides operational and statistical information about virtual links associated with this router.

**Output** **OSPF Virtual Link Output** — The following table describes OSPF virtual-link output fields.

| Label           | Description                                                                                                                                                                                                                                                                                                                 |
|-----------------|-----------------------------------------------------------------------------------------------------------------------------------------------------------------------------------------------------------------------------------------------------------------------------------------------------------------------------|
| Nbr Rtr ID      | The router ID(s) of neighboring routers.                                                                                                                                                                                                                                                                                    |
| Area Id         | A 32-bit integer which identifies an area.                                                                                                                                                                                                                                                                                  |
| Local Interface | The IP address of the local egress interface used to maintain the adjacency to reach this virtual neighbor.                                                                                                                                                                                                                 |
| Metric          | The metric value associated with the route. This value is used when importing this static route into other protocols. When the metric is configured as zero then the metric configured in OSPF, default-import-metric, applies. This value is also used to determine which static route to install in the forwarding table. |
| State           | The operational state of the virtual link to the neighboring router.                                                                                                                                                                                                                                                        |
| Authentication  | Specifies whether authentication is enabled for the interface or virtual link.                                                                                                                                                                                                                                              |
| Hello Intrval   | Specifies the length of time, in seconds, between the Hello packets that the router sends on the interface.                                                                                                                                                                                                                 |
| Rtr Dead Intrvl | Specifies the total number of OSPF packets received where the dead interval given in the packet was not equal to that configured on this interface since the OSPF admin status was enabled.                                                                                                                                 |
| Tot Rx Packets  | Specifies the total number of OSPF packets received on this interface since the OSPF admin status was enabled.                                                                                                                                                                                                              |
| Rx Hellos       | Specifies the total number of OSPF Hello packets received on this interface since the OSPF admin status was enabled.                                                                                                                                                                                                        |
| Rx DBDs         | Specifies the total number of OSPF DataBase Description packets received on this interface since the OSPF administrative status was enabled.                                                                                                                                                                                |
| Rx LSRs         | Specifies the total number of Link State Requests (LSRs) received on this interface since the OSPF admin status was enabled.                                                                                                                                                                                                |

| Label          | Description (Continued)                                                                                                                                                                          |
|----------------|--------------------------------------------------------------------------------------------------------------------------------------------------------------------------------------------------|
| Rx LSUs        | Specifies the total number of Link State Updates (LSUs) received on this interface since the OSPF admin status was enabled.                                                                      |
| Rx LS Acks     | Specifies the total number of Link State Acknowledgements received on this interface since the OSPF admin status was enabled.                                                                    |
| Tot Tx Packets | Specifies the total number of OSPF packets transmitted on this virtual interface since it was created.                                                                                           |
| Tx Hellos      | Specifies the total number of OSPF Hello packets transmitted on this virtual interface since it was created.                                                                                     |
| Tx DBDs        | Specifies the total number of OSPF database description packets transmitted on this virtual interface.                                                                                           |
| Tx LSRs        | Specifies the total number of OSPF Link State Requests (LSRs) transmitted on this virtual interface.                                                                                             |
| Tx LSUs        | Specifies the total number of OSPF Hello packets transmitted on this interface since the OSPF admin status was enabled.                                                                          |
| Tx LS Acks     | Specifies the total number of OSPF Link State Acknowledgements (LSA) transmitted on this virtual interface.                                                                                      |
| Retransmits    | Specifies the total number of OSPF retransmits sent on this interface since the OSPF admin status was last enabled.                                                                              |
| Discards       | Specifies the total number of OSPF packets discarded on this interface since the OSPF admin status was last enabled.                                                                             |
| Bad Networks   | Specifies the total number of OSPF packets received with invalid network or mask since the OSPF admin status was last enabled.                                                                   |
| Bad Versions   | Specifies the total number of OSPF packets received with bad OSPF version numbers since the OSPF admin status was last enabled.                                                                  |
| Bad Areas      | Specifies the total number of OSPF packets received with an area mismatch since the OSPF admin status was last enabled.                                                                          |
| Bad Dest Addr  | Specifies the total number of OSPF packets received with the incorrect IP destination address since the OSPF admin status was last enabled.                                                      |
| Bad Auth Types | Specifies the total number of OSPF packets received with an invalid authorization type since the OSPF admin status was last enabled.                                                             |
| Auth Failures  | Specifies the total number of OSPF packets received with an invalid authorization key since the OSPF admin status was last enabled.                                                              |
| Bad Neighbors  | Specifies the total number of OSPF packets received where the neighbor information does not match the information this router has for the neighbor since the OSPF admin status was last enabled. |

## Show Commands

| Label          | Description (Continued)                                                                                                                                                                          |
|----------------|--------------------------------------------------------------------------------------------------------------------------------------------------------------------------------------------------|
| Bad Pkt Types  | Specifies the total number of OSPF packets received with an invalid OSPF packet type since the OSPF admin status was last enabled.                                                               |
| Bad Lengths    | Specifies the total number of OSPF packets received on this interface with a total length not equal to the length given in the packet itself since the OSPF admin status was last enabled.       |
| Bad Hello Int. | Specifies the total number of OSPF packets received where the hello interval given in packet was not equal to that configured on this interface since the OSPF admin status was last enabled.    |
| Bad Dead Int.  | Specifies the total number of OSPF packets received where the dead interval given in the packet was not equal to that configured on this interface since the OSPF admin status was last enabled. |
| Bad Options    | Specifies the total number of OSPF packets received with an option that does not match those configured for this interface or area since the OSPF admin status was last enabled.                 |
| Retrans Intrvl | Specifies the length of time, in seconds, that OSPF waits before retransmitting an unacknowledged link state advertisement (LSA) to an OSPF neighbor.                                            |
| Transit Delay  | Specifies the time, in seconds, that it takes to transmit a link state advertisement (LSA) on the interface or virtual link.                                                                     |
| Last Event     | Specifies the date and time when an event was last associated with this OSPF interface.                                                                                                          |

### Sample Output

```
A:ALA-A# show router ospf 1 virtual-link
=====
OSPF Virtual Links
=====
Nbr Rtr Id Area Id Local Interface Metric State

180.0.0.10 0.0.0.1 180.1.7.12 300 PToP
180.0.0.10 0.0.0.2 180.2.7.12 300 PToP

No. of OSPF Virtual Links: 2
=====
A:ALA-A#

A:ALA-A# show router ospf virtual-link detail
=====
OSPF Virtual Links (detailed)
=====
Neighbor Router Id : 180.0.0.10
```

```

Nbr Router Id : 180.0.0.10 Area Id : 0.0.0.1
Local Interface: 180.1.7.12 Metric : 300
State : Point To Point Admin State : Up
Hello Intrvl : 10 sec Rtr Dead Intrvl: 60 sec
Tot Rx Packets : 43022 Tot Tx Packets : 42964
Rx Hellos : 24834 Tx Hellos : 24853
Rx DBDs : 3 Tx DBDs : 2
Rx LSRs : 0 Tx LSRs : 0
Rx LSUs : 15966 Tx LSUs : 16352
Rx LS Acks : 2219 Tx LS Acks : 1757
Retransmits : 0 Discards : 0
Bad Networks : 0 Bad Versions : 0
Bad Areas : 0 Bad Dest Adrs : 0
Bad Auth Types : 0 Auth Failures : 0
Bad Neighbors : 0 Bad Pkt Types : 0
Bad Lengths : 0 Bad Hello Int. : 0
Bad Dead Int. : 0 Bad Options : 0
Retrans Intrvl : 5 sec Transit Delay : 1 sec
Last Event : 11/07/2006 17:11:56 Authentication : None

```

```

Neighbor Router Id : 180.0.0.10

```

```

Nbr Router Id : 180.0.0.10 Area Id : 0.0.0.2
Local Interface: 180.2.7.12 Metric : 300
State : Point To Point Admin State : Up
Hello Intrvl : 10 sec Rtr Dead Intrvl: 60 sec
Tot Rx Packets : 43073 Tot Tx Packets : 43034
Rx Hellos : 24851 Tx Hellos : 24844
Rx DBDs : 3 Tx DBDs : 2
Rx LSRs : 1 Tx LSRs : 1
Rx LSUs : 18071 Tx LSUs : 17853
Rx LS Acks : 147 Tx LS Acks : 334
Retransmits : 0 Discards : 0
Bad Networks : 0 Bad Versions : 0
Bad Areas : 0 Bad Dest Adrs : 0
Bad Auth Types : 0 Auth Failures : 0
Bad Neighbors : 0 Bad Pkt Types : 0
Bad Lengths : 0 Bad Hello Int. : 0
Bad Dead Int. : 0 Bad Options : 0
Retrans Intrvl : 5 sec Transit Delay : 1 sec
Last Event : 11/07/2006 17:12:00 Authentication : MD5

```

```

=====
A:ALA-A#

```

## virtual-neighbor

**Syntax** `virtual-neighbor [remote router-id] [detail]`

**Context** show>router>ospf  
show>router>ospf3

**Description** This command displays virtual neighbor information.

**Parameters** **remote** *router-id* — Displays the specified router ID. This reduces the amount of output displayed.  
**detail** — Produces detailed information on the virtual neighbor. This option produces a large amount of data. It is recommended to use **detail** only when requesting information for a specific neighbor.

**Output** **OSPF Virtual Neighbor Output** — The following table describes OSPF virtual neighbor output fields.

| Label            | Description                                                                                                                                                                                      |
|------------------|--------------------------------------------------------------------------------------------------------------------------------------------------------------------------------------------------|
| Nbr IP Addr      | The IP address this neighbor is using in its IP source address. Note that, on addressless links, this will not be 0.0.0.0, but the address of another of the neighbor's interfaces.              |
| Nbr Rtr ID       | Specifies the router ID(s) of neighboring routers.                                                                                                                                               |
| Transit Area     | Specifies the transit area ID that links the backbone area with the area that has no physical connection with the backbone.                                                                      |
| Retrans Q Length | The current length of the retransmission queue.                                                                                                                                                  |
| No. of Neighbors | Specifies the total number of OSPF neighbors adjacent on this interface, in a state of INIT or greater, since the OSPF admin status was enabled.                                                 |
| Nbr State        | Specifies the operational state of the virtual link to the neighboring router.                                                                                                                   |
| Options          | Specifies the total number of OSPF packets received with an option that does not match those configured for this virtual interface or transit area since the OSPF admin status was enabled.      |
| Events           | Specifies the total number of events that have occurred since the OSPF admin status was enabled.                                                                                                 |
| Last Event Time  | Specifies the date and time when an event was last associated with this OSPF interface.                                                                                                          |
| Up Time          | Specifies the uninterrupted time, in hundredths of seconds, the adjacency to this neighbor has been up.                                                                                          |
| Time Before Dead | Specifies the amount of time, in seconds, until the dead router interval expires.                                                                                                                |
| Bad Nbr States   | Specifies the total number of OSPF packets received where the neighbor information does not match the information this router has for the neighbor since the OSPF admin status was last enabled. |

| Label             | Description (Continued)                                                                                                                                                                |
|-------------------|----------------------------------------------------------------------------------------------------------------------------------------------------------------------------------------|
| LSA Inst fails    | Specifies the total number of times an LSA could not be installed into the LSDB due to a resource allocation issue since the OSPF admin status was last enabled.                       |
| Bad Seq Num       | Specifies the total number of times when a database description packet was received with a sequence number mismatch since the OSPF admin status was last enabled.                      |
| Bad MTUs          | Specifies the total number of times when the MTU in a received database description packet was larger than the MTU of the receiving interface since the OSPF admin status was enabled. |
| Bad Packets       | Specifies the total number of times when an LS update was received with an illegal LS type or an option mismatch since the OSPF admin status was enabled.                              |
| LSA not in LSDB   | Specifies the total number of times when an LS request was received for an LSA not installed in the LSDB of this router since the OSPF admin status was enabled.                       |
| Option Mismatches | Specifies the total number of times when a LS update was received with an option mismatch since the OSPF admin status was enabled.                                                     |
| Nbr Duplicates    | Specifies the total number of times when a duplicate database description packet was received during the Exchange state since the OSPF admin status was enabled.                       |

### Sample Output

```
A:ALA-A# show router ospf 1 virtual-neighbor
=====
OSPF Virtual Neighbors
=====
Nbr IP Addr Nbr Rtr Id Nbr State Transit Area RetxQ Len Dead Time

180.1.6.10 180.0.0.10 Full 0.0.0.1 0 58
180.2.9.10 180.0.0.10 Full 0.0.0.2 0 52

No. of Neighbors: 2
=====
A:ALA-A#

A:ALA-A# show router ospf virtual-neighbor detail
=====
OSPF Virtual Neighbors
=====
Virtual Neighbor Router Id : 180.0.0.10

Neighbor IP Addr : 180.1.6.10 Neighbor Rtr Id : 180.0.0.10
Neighbor State : Full Transit Area : 0.0.0.1
Retrans Q Length : 0 Options : -E--
```

## Show Commands

```
Events : 4 Last Event Time : 11/07/2006 17:11:56
Up Time : 2d 17:47:17 Time Before Dead : 57 sec
Bad Nbr States : 1 LSA Inst fails : 0
Bad Seq Nums : 0 Bad MTUs : 0
Bad Packets : 0 LSA not in LSDB : 0
Option Mismatches: 0 Nbr Duplicates : 0

Virtual Neighbor Router Id : 180.0.0.10

Neighbor IP Addr : 180.2.9.10 Neighbor Rtr Id : 180.0.0.10
Neighbor State : Full Transit Area : 0.0.0.2
Retrans Q Length : 0 Options : -E--
Events : 4 Last Event Time : 11/07/2006 17:11:59
Up Time : 2d 17:47:14 Time Before Dead : 59 sec
Bad Nbr States : 1 LSA Inst fails : 0
Bad Seq Nums : 0 Bad MTUs : 0
Bad Packets : 0 LSA not in LSDB : 0
Option Mismatches: 0 Nbr Duplicates : 0
=====
A:ALA-A#
```



---

## Clear Commands

### ospf

**Syntax** `ospf [ospf-instance]`

**Context** `clear>router`

**Description** This command clears and resets OSPF protocol entities.

**Parameters** *ospf-instance* — Clears the configured specified VR-ID.

**Values** 1 — 4294967295

### database

**Syntax** `database [purge]`

**Context** `clear>router>ospf`  
`clear>router>ospf3`

**Description** This command clears all LSAs received from other nodes.

Sets all adjacencies better than two way to one way.

Refreshes all self originated LSAs

**Parameters** **purge** — The purge parameter also clears all self-originated LSAs and re-originates all self-originated LSAs

### export

**Syntax** `export`

**Context** `clear>router>ospf`  
`clear>router>ospf3`

**Description** Re-evaluates all effective export policies

### neighbor

**Syntax** `neighbor [ip-int-name | ip-address]`

**Context** `clear>router>ospf`  
`clear>router>ospf3`

**Description** Marks the neighbor as dead and re-initiates the affected adjacencies.

## Clear Commands

**Parameters**    *ip-int-name* — Clear all neighbors for the interface specified by this interface name.  
*ip-address* — Clear all neighbors for the interface specified by this IP-address

### statistics

**Syntax**        **statistics**

**Context**        clear>router>ospf  
                  clear>router>ospf3

**Description**    Clears all neighbor, router, interface, SPF and global statistics of this OSPF instance.

---

## OSPF Debug Commands

### ospf

**Syntax** `ospf [ospf-instance]`

**Context** debug>router

**Description** Indicates the OSPF instance for debugging purposes.

**Parameters** *ospf-instance* — The OSPF instance.

**Values** 1 — 31

### area

**Syntax** `area [area-id]`  
`no area`

**Context** debug>router>ospf  
debug>router>ospf3

**Description** This command enables debugging for an OSPF area.

**Parameters** *area-id* — Specify the OSPF area ID expressed in dotted decimal notation or as a 32-bit decimal integer.

### area-range

**Syntax** `area-range [ip-address]`  
`no area-range`

**Context** debug>router>ospf  
debug>router>ospf3

**Description** This command enables debugging for an OSPF area range.

**Parameters** *ip-address* — Specify the IP address for the range used by the ABR to advertise the area into another area.

## OSPF Debug Commands

### cspf

|                    |                                                                                         |
|--------------------|-----------------------------------------------------------------------------------------|
| <b>Syntax</b>      | <b>cspf</b> [ <i>ip-address</i> ]<br><b>no cspf</b>                                     |
| <b>Context</b>     | debug>router>ospf<br>debug>router>ospf3                                                 |
| <b>Description</b> | This command enables debugging for an OSPF constraint-based shortest path first (CSPF). |
| <b>Parameters</b>  | <i>ip-address</i> — Specify the IP address for the range used for CSPF.                 |

### graceful-restart

|                    |                                                                     |
|--------------------|---------------------------------------------------------------------|
| <b>Syntax</b>      | <b>[no] graceful-restart</b>                                        |
| <b>Context</b>     | debug>router>ospf<br>debug>router>ospf3                             |
| <b>Description</b> | This command enables debugging for OSPF and OSPF3 graceful-restart. |

### interface

|                    |                                                                                                                                                                                                                                                                                                                                                                                                              |
|--------------------|--------------------------------------------------------------------------------------------------------------------------------------------------------------------------------------------------------------------------------------------------------------------------------------------------------------------------------------------------------------------------------------------------------------|
| <b>Syntax</b>      | <b>interface</b> [ <i>ip-int-name</i>   <i>ip-address</i> ]<br><b>no interface</b>                                                                                                                                                                                                                                                                                                                           |
| <b>Context</b>     | debug>router>ospf<br>debug>router>ospf3                                                                                                                                                                                                                                                                                                                                                                      |
| <b>Description</b> | This command enables debugging for an OSPF and OSPF3 interface.                                                                                                                                                                                                                                                                                                                                              |
| <b>Parameters</b>  | <i>ip-int-name</i> — Specify the IP interface name. An interface name cannot be in the form of an IP address. Interface names can be any string up to 32 characters long composed of printable, 7-bit ASCII characters. If the string contains special characters (#, \$, spaces, etc.), the entire string must be enclosed within double quotes.<br><i>ip-address</i> — Specify the interface's IP address. |

### leak

|                    |                                                     |
|--------------------|-----------------------------------------------------|
| <b>Syntax</b>      | <b>leak</b> [ <i>ip-address</i> ]<br><b>no leak</b> |
| <b>Context</b>     | debug>router>ospf<br>debug>router>ospf3             |
| <b>Description</b> | This command enables debugging for OSPF leaks.      |

**Parameters** *ip-address* — Specify the IP address to debug OSPF leaks.

## lsdb

**Syntax** **lsdb** [**type**] [*ls-id*] [*adv-rtr-id*] [**area** *area-id*]  
**no lsdb**

**Context** debug>router>ospf  
 debug>router>ospf3

**Description** This command enables debugging for an OSPF link-state database (LSDB).

**Parameters** *type* — Specifies the OSPF link-state database (LSDB) type.

**Values** router, network, summary, asbr, extern, nssa, area-opaque, as-opaque, link-opaque

*ls-id* — Specifies an LSA type specific field containing either a router ID or an IP address. It identifies the piece of the routing domain being described by the advertisement.

*adv-rtr-id* — Specifies the router identifier of the router advertising the LSA.

*area-id* — Specifies a 32-bit integer uniquely identifying an area.

## misc

**Syntax** [**no**] **misc**

**Context** debug>router>ospf  
 debug>router>ospf3

**Description** This command enables debugging for miscellaneous OSPF events.

## neighbor

**Syntax** **neighbor** [*ip-int-name* | *ip-address*]  
**no neighbor**

**Context** debug>router>ospf  
 debug>router>ospf3

**Description** This command enables debugging for an OSPF or OSPF3 neighbor.

**Parameters** *ip-int-name* — Specifies the neighbor interface name.

*ip-address* — Specifies neighbor information for the neighbor identified by the the specified router ID.

## OSPF Debug Commands

### nssa-range

|                    |                                                                 |
|--------------------|-----------------------------------------------------------------|
| <b>Syntax</b>      | <b>nssa-range</b> [ <i>ip-address</i> ]<br><b>no nssa-range</b> |
| <b>Context</b>     | debug>router>ospf<br>debug>router>ospf3                         |
| <b>Description</b> | This command enables debugging for an NSSA range.               |
| <b>Parameters</b>  | <i>ip-address</i> — Specifies the IP address range to debug.    |

### packet

|                    |                                                                                                                                                                                                                                                                                                                                         |
|--------------------|-----------------------------------------------------------------------------------------------------------------------------------------------------------------------------------------------------------------------------------------------------------------------------------------------------------------------------------------|
| <b>Syntax</b>      | <b>packet</b> [ <i>packet-type</i> ] [ <i>ip-address</i> ]<br><b>no packet</b>                                                                                                                                                                                                                                                          |
| <b>Context</b>     | debug>router>ospf<br>debug>router>ospf3                                                                                                                                                                                                                                                                                                 |
| <b>Description</b> | This command enables debugging for OSPF packets.                                                                                                                                                                                                                                                                                        |
| <b>Parameters</b>  | <i>packet-type</i> — Specifies the OSPF packet type to debug.<br><b>Values</b> hello, dbdescr, lsrequest, lsupdate, lsack<br><i>ip-address</i> — Specifies the IP address to debug.<br><b>Values</b> ipv4-address: a.b.c.d<br>ipv6-address: x:x:x:x:x:x:x (eight 16-bit pieces)<br>x:x:x:x:x:d.d.d.d<br>x: [0 — FFFF]H<br>d: [0 — 255]D |

### rtm

|                    |                                                                                                                                                                                                            |
|--------------------|------------------------------------------------------------------------------------------------------------------------------------------------------------------------------------------------------------|
| <b>Syntax</b>      | <b>rtm</b> [ <i>ip-address</i> ]<br><b>no rtm</b>                                                                                                                                                          |
| <b>Context</b>     | debug>router>ospf<br>debug>router>ospf3                                                                                                                                                                    |
| <b>Description</b> | This command enables debugging for OSPF RTM.                                                                                                                                                               |
| <b>Parameters</b>  | <i>ip-address</i> — Specifies the IP address to debug.<br><b>Values</b> ipv4-address: a.b.c.d<br>ipv6-address: x:x:x:x:x:x:x (eight 16-bit pieces)<br>x:x:x:x:x:d.d.d.d<br>x: [0 — FFFF]H<br>d: [0 — 255]D |

## spf

|                    |                                                                                                                                                                                                                                                     |
|--------------------|-----------------------------------------------------------------------------------------------------------------------------------------------------------------------------------------------------------------------------------------------------|
| <b>Syntax</b>      | <b>spf</b> [ <i>type</i> ] [ <i>dest-addr</i> ]<br><b>no spf</b>                                                                                                                                                                                    |
| <b>Context</b>     | debug>router>ospf                                                                                                                                                                                                                                   |
| <b>Description</b> | This command enables debugging for OSPF SPF. Information regarding overall SPF start and stop times will be shown. To see detailed information regarding the SPF calculation of a given route, the route must be specified as an optional argument. |
| <b>Parameters</b>  | <i>type</i> — Specifies the area to debug<br><b>Values</b> intra-area, inter-area, external<br><i>dest-addr</i> — Specifies the destination IP address to debug.                                                                                    |

## virtual-neighbor

|                    |                                                                             |
|--------------------|-----------------------------------------------------------------------------|
| <b>Syntax</b>      | <b>virtual-neighbor</b> [ <i>ip-address</i> ]<br><b>no virtual-neighbor</b> |
| <b>Context</b>     | debug>router>ospf                                                           |
| <b>Description</b> | This command enables debugging for an OSPF virtual neighbor.                |
| <b>Parameters</b>  | <i>ip-address</i> — Specifies the IP address of the virtual neighbor.       |





---

## In This Chapter

This chapter provides information to configure Intermediate System to Intermediate System (IS-IS).

Topics in this chapter include:

- [Configuring IS-IS on page 442](#)
  - [Routing on page 443](#)
    - [IS-IS Frequently Used Terms on page 445](#)
    - [ISO Network Addressing on page 446](#)
    - [IS-IS PDU Configuration on page 448](#)
    - [IS-IS Operations on page 448](#)
    - [IS-IS Route Summarization on page 449](#)
    - [IS-IS Multi-Topology for IPv6 on page 450](#)
    - [IS-IS Administrative Tags on page 451](#)
- [IS-IS Configuration Process Overview on page 459](#)
- [Configuration Notes on page 460](#)

## Configuring IS-IS

Intermediate-system-to-intermediate-system (IS-IS) is a link-state interior gateway protocol (IGP) which uses the Shortest Path First (SPF) algorithm to determine routes. Routing decisions are made using the link-state information. IS-IS evaluates topology changes and, if necessary, performs SPF recalculations.

Entities within IS-IS include networks, intermediate systems, and end systems. In IS-IS, a network is an autonomous system (AS), or routing domain, with end systems and intermediate systems. A router, such as a 7750 SR-Series router, is an intermediate system. End systems are network devices which send and receive protocol data units (PDUs), the OSI term for packets. Intermediate systems send, receive, and forward PDUs.

End system and intermediate system protocols allow routers and nodes to identify each other. IS-IS sends out link-state updates periodically throughout the network, so each router can maintain current network topology information.

IS-IS supports large ASs by using a two-level hierarchy. A large AS can be administratively divided into smaller, more manageable areas. A system logically belongs to one area. Level 1 routing is performed within an area. Level 2 routing is performed between areas. 7750 SR-Series routers can be configured as Level 1, Level 2, or both Level 1/2.

Figure 15 displays an example of an IS-IS routing domain.

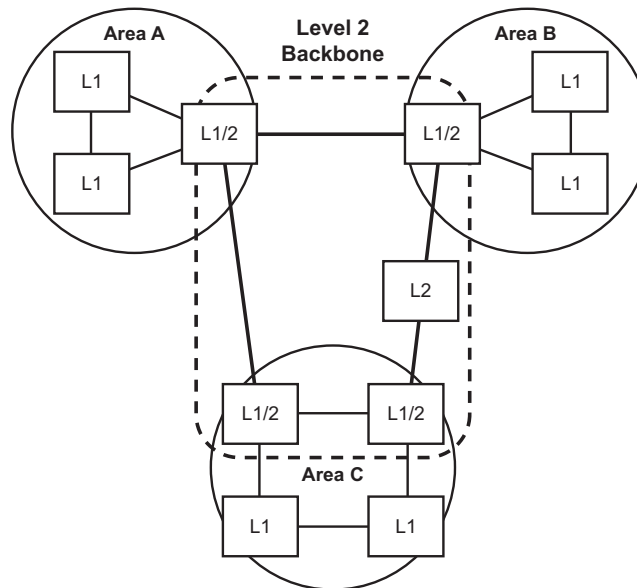

OSRG033

Figure 15: IS-IS Routing Domain

## Routing

OSI IS-IS routing uses two-level hierarchical routing. A routing domain can be partitioned into areas. Level 1 routers know the topology in their area, including all routers and end systems in their area but do not know the identity of routers or destinations outside of their area. Level 1 routers forward traffic with destinations outside of their area to a Level 2 router in their area.

Level 2 routers know the Level 2 topology, and know which addresses are reachable by each Level 2 router. Level 2 routers do not need to know the topology within any Level 1 area, except to the extent that a Level 2 router can also be a Level 1 router within a single area. By default, only Level 2 routers can exchange PDUs or routing information directly with external routers located outside the routing domain.

In IS-IS, there are two types of routers:

- Level 1 intermediate systems — Routing is performed based on the area ID portion of the ISO address called the *network entity title* (NET). Level 1 systems route within an area. They recognize, based on the destination address, whether the destination is within the area. If so, they route toward the destination. If not, they route to the nearest Level 2 router.
- Level 2 intermediate systems — Routing is performed based on the area address. They route toward other areas, disregarding other area's internal structure. A Level 2 intermediate system can also be configured as a Level 1 intermediate system in the same area.

The Level 1 router's area address portion is manually configured (see [ISO Network Addressing on page 446](#)). A Level 1 router will not become a neighbor with a node that does not have a common area address. However, if a Level 1 router has area addresses A, B, and C, and a neighbor has area addresses B and D, then the Level 1 router will accept the other node as a neighbor, as address B is common to both routers. Level 2 adjacencies are formed with other Level 2 nodes whose area addresses do not overlap. If the area addresses do not overlap, the link is considered by both routers to be Level 2 only and only Level 2 LSPDUs flow on the link.

Within an area, Level 1 routers exchange LSPs which identify the IP addresses reachable by each router. Specifically, zero or more IP address, subnet mask, and metric combinations can be included in each LSP. Each Level 1 router is manually configured with the IP address, subnet mask, and metric combinations, which are reachable on each interface. A Level 1 router routes as follows:

- If a specified destination address matches an IP address, subnet mask, or metric reachable within the area, the PDU is routed via Level 1 routing.
- If a specified destination address does not match any IP address, subnet mask, or metric combinations listed as reachable within the area, the PDU is routed towards the nearest Level 2 router.

## Configuring IS-IS

Level 2 routers include in their LSPs, a complete list of IP address, subnet mask, and metrics specifying all the IP addresses which reachable in their area. This information can be obtained from a combination of the Level 1 LSPs (by Level 1 routers in the same area). Level 2 routers can also report external reachability information, corresponding to addresses reachable by routers in other routing domains or autonomous systems.

## IS-IS Frequently Used Terms

- **Area** — An area is a routing sub-domain which maintains detailed routing information about its own internal composition, and also maintains routing information which allows it to reach other routing sub-domains. Areas correspond to the Level 1 sub-domain.
- **End system** — End systems send NPDUs to other systems and receive NPDUs from other systems, but do not relay NPDUs. This International Standard does not specify any additional end system functions beyond those supplied by ISO 8473 and ISO 9542.
- **Neighbor** — A neighbor is an adjacent system reachable by traversing a single sub-network by a PDU.
- **Adjacency** — An adjacency is a portion of the local routing information which pertains to the reachability of a single neighboring end or intermediate system over a single circuit. Adjacencies are used as input to the decision process to form paths through the routing domain. A separate adjacency is created for each neighbor on a circuit and for each level of routing (Level 1 and Level 2) on a broadcast circuit.
- **Circuit** — The subset of the local routing information base pertinent to a single local Subnetwork Point of Attachments (SNPAs).
- **Link** — The communication path between two neighbors. A link is up when communication is possible between the two SNPAs.
- **Designated IS** — The intermediate system on a LAN which is designated to perform additional duties. In particular, the designated IS generates link-state PDUs on behalf of the LAN, treating the LAN as a pseudonode.
- **Pseudonode** — Where a broadcast sub-network has  $n$  connected intermediate systems, the broadcast sub-network itself is considered to be a pseudonode. The pseudonode has links to each of the  $n$  intermediate systems and each of the ISs has a single link to the pseudonode (rather than  $n-1$  links to each of the other intermediate systems). Link-state PDUs are generated on behalf of the pseudonode by the designated IS.
- **Broadcast sub-network** — A multi-access subnetwork that supports the capability of addressing a group of attached systems with a single PDU.
- **General topology sub-network** — A topology that is modeled as a set of point-to-point links, each of which connects two systems. There are several generic types of general topology subnetworks, multipoint links, permanent point-to-point links, dynamic and static point-to-point links.
- **Routing sub-domain** — A routing sub-domain consists of a set of intermediate systems and end systems located within the same routing domain.
- **Level 2 sub-domain** — Level 2 sub-domain is the set of all Level 2 intermediate systems in a routing domain.

## ISO Network Addressing

IS-IS uses ISO network addresses. Each address identifies a point of connection to the network, such as a router interface, and is called a Network Service Access Point (NSAP).

An end system can have multiple NSAP addresses, in which case the addresses differ only by the last byte (called the *n-selector*). Each NSAP represents a service that is available at that node. In addition to having multiple services, a single node can belong to multiple areas.

Each network entity has a special network address called a Network Entity Title (NET). Structurally, an NET is identical to an NSAP address but has an n-selector of 00. Most end systems have one NET. Intermediate systems can have up to three area IDs (area addresses).

NSAP addresses are divided into three parts. Only the area ID portion is configurable.

- Area ID — A variable length field between 1 and 13 bytes long. This includes the Authority and Format Identifier (AFI) as the most significant byte and the area ID.
- System ID — A six-byte system identification. This value is not configurable. The system ID is derived from the system or router ID.
- Selector ID — A one-byte selector identification that must contain zeros when configuring a NET. This value is not configurable. The selector ID is always 00.

Of the total 20 bytes comprising the NET, only the first 13 bytes, the area ID portion, can be manually configured. As few as one byte can be entered or, at most, 13 bytes. If less than 13 bytes are entered, the rest is padded with zeros.

Routers with common area addresses form Level 1 adjacencies. Routers with no common NET addresses form Level 2 adjacencies, if they are capable ([Figure 16](#)).

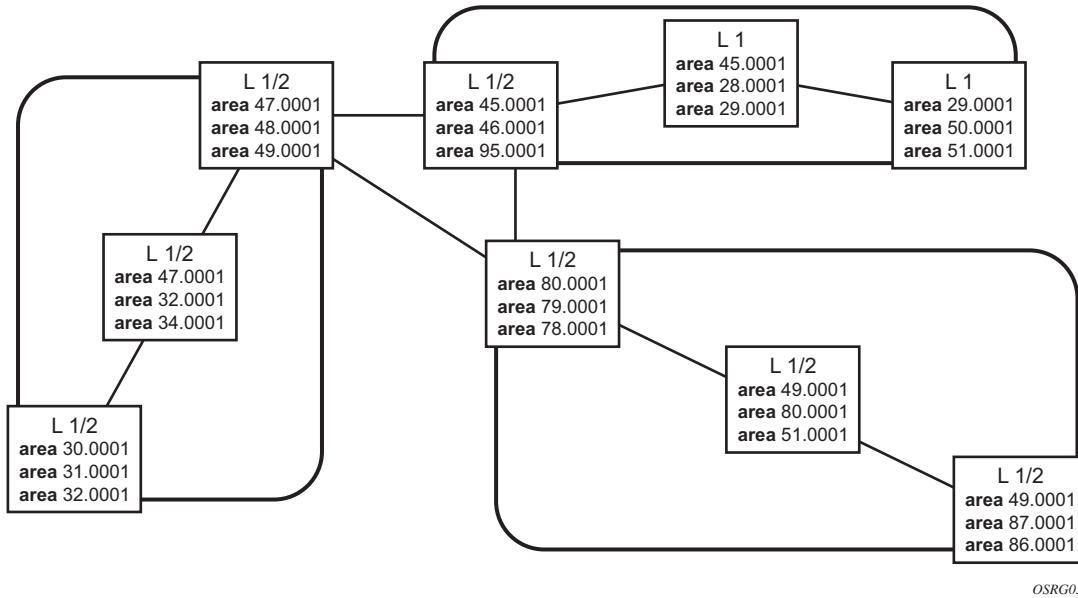

Figure 16: Using Area Addresses to Form Adjacencies

### IS-IS PDU Configuration

The following PDUs are used by IS-IS to exchange protocol information:

- IS-IS hello PDU — Routers with IS-IS enabled send hello PDUs to IS-IS-enabled interfaces to discover neighbors and establish adjacencies.
  - Link-state PDUs — Contain information about the state of adjacencies to neighboring IS-IS systems. LSPs are flooded periodically throughout an area.
  - Complete sequence number PDUs — In order for all routers to maintain the same information, CSNPs inform other routers that some LSPs can be outdated or missing from their database. CSNPs contain a complete list of all LSPs in the current IS-IS database.
  - Partial sequence number PDUs (PSNPs) — PSNPs are used to request missing LSPs and acknowledge that an LSP was received.
- 

### IS-IS Operations

7750 SR-Series routers perform IS-IS routing as follows:

- Hello PDUs are sent to the IS-IS-enabled interfaces to discover neighbors and establish adjacencies.
- IS-IS neighbor relationships are formed if the hello PDUs contain information that meets the criteria for forming an adjacency.
- SRs can build a link-state PDU based upon their local interfaces that are configured for IS-IS and prefixes learned from other adjacent routers.
- SRs flood LSPs to the adjacent neighbors except the neighbor from which they received the same LSP. The link-state database is constructed from these LSPs.
- A Shortest Path Tree (SPT) is calculated by each IS, and from this SPT the routing table is built.



## IS-IS Route Summarization

IS-IS IPv4 route summarization allows users to create aggregate IPv4 addresses that include multiple groups of IPv4 addresses for a given IS-IS level. IPv4 Routes redistributed from other routing protocols also can be summarized. It is similar to the OSPF area-range command. IS-IS IPv4 route summarization helps to reduce the size of the LSDB and the IPv4 routing table, and it also helps to reduce the chance of route flapping.

IPv4 route summarization supports:

- Level 1, Level 1-2, and Level 2
- Route summarization for the IPv4 routes redistributed from other protocols
- Metric used to advertise the summary address will be the smallest metric of all the more specific IPv4 routes.

## IS-IS Multi-Topology for IPv6

IS-IS IPv6 TLVs for IPv6 routing is supported in the 7750 SR-Series. This is considered native IPv6 routing with IS-IS. It has a limitation that IPv4 and IPv6 topologies must be congruent, otherwise traffic may be black holed. Service providers should ensure that the IPv4 topology and IPv6 topology are the same. With the 7750 SR-Series IS-IS multi-topology service providers can use different topologies for IPv4 and IPv6.

The implementation is compliant with draft-ietf-isis-wg-multi-topology-xx.txt, *M-ISIS: Multi Topology (MT) Routing in IS-IS*.

The following MT topologies are supported:

- MT ID #0: Equivalent to the standard IS-IS topology.
- MT ID #2: Reserved for IPv6 routing topology

## IS-IS Administrative Tags

IS-IS admin tags enable a network administrator to configure route tags to tag IS-IS route prefixes. These tags can subsequently be used to control Intermediate System-to-Intermediate System (IS-IS) route redistribution or route leaking.

The IS-IS support for route tags allows the tagging of IP addresses of an interface and use the tag to apply administrative policy with a route map. A network administrator can also tag a summary route and then use a route policy to match the tag and set one or more attributes for the route.

Using these administrative policies allow the operator to control how a router handles the routes it receives from and sends to its IS-IS neighboring routers. Administrative policies are also used to govern the installation of routes in the routing table.

Route tags allow:

- Policies to redistribute routes received from other protocols in the routing table to IS-IS.
  - Policies to redistribute routes between levels in an IS-IS routing hierarchy.
  - Policies to summarize routes redistributed into IS-IS or within IS-IS by creating aggregate (summary) addresses.
- 

## Setting Route Tags

IS-IS route tags are configurable in the following ways:

- Setting a route tag for an IS-IS interface.
- Setting a route tag on an IS-IS passive interface.
- Setting a route tag for a route redistributed from another protocol to IS-IS.
- Setting a route tag for a route redistributed from one IS-IS level to another IS-IS level.
- Setting a route tag for an IS-IS default route.
- Setting a route tag for an IS-IS summary address.

### Using Route Tags

Although an operator on this or another (neighboring) IS-IS router has configured setting of the IS-IS administrative tags it will not have any effect unless policies are configured to instruct how to process the given tag value.

Policies can process tags where ISIS is either the origin, destination or both origin and destination protocol.

```
config>router>policy-options>policy-statement>entry>from
config>router>policy-options>policy-statement>entry>action tag tag-value
config>router>policy-options>policy-statement# default-action tag tag-value
```

## IP Fast-reroute (IP FRR) For IS-IS Prefixes

Refer to [IP Fast-reroute \(IP FRR\) For OSPF and IS-IS Prefixes on page 307](#) for IP FRR for OSPF prefixes.

---

### IP FRR Configuration

The user first enables Loop-Free Alternate (LFA) computation by SPF under the IS-IS routing protocol level or under the OSPF routing protocol instance level:

```
config>router>isis>loopfree-alternate
config>router>ospf>loopfree-alternate
config>service>vprn>ospf>loopfree-alternate
```

The above commands instruct the IGP SPF to attempt to pre-compute both a primary next-hop and an LFA next-hop for every learned prefix. When found, the LFA next-hop is populated into the RTM along with the primary next-hop for the prefix.

Next the user enables IP FRR to cause RTM to download to IOM a LFA next-hop, when found by SPF, in addition to the primary next-hop for each prefix in the FIB.

```
config>router>ip-fast-reroute
```

### Reducing the Scope of the LFA Calculation by SPF

The user can instruct IGP to not include all interfaces participating in a specific IS-IS level or OSPF area in the SPF LFA computation. This provides a way of reducing the LFA SPF calculation where it is not needed.

```
config>router>isis>level>loopfree-alternate-exclude
```

```
config>router>ospf>area>loopfree-alternate-exclude
```

The user can also exclude a specific IP interface from being included in the LFA SPF computation by IS-IS or OSPF:

```
config>router>isis>interface> loopfree-alternate-exclude
```

```
config>router>ospf>area>interface> loopfree-alternate-exclude
```

Note that when an interface is excluded from the LFA SPF in IS-IS, it is excluded in both level 1 and level 2. When the user excludes an interface from the LFA SPF in OSPF, it is excluded in all areas. However, the above OSPF command can only be executed under the area in which the specified interface is primary and once enabled, the interface is excluded in that area and in all other areas where the interface is secondary. If the user attempts to apply it to an area where the interface is secondary, the command will fail.

Finally, the user can apply the same above commands for an OSPF instance within a VPRN service:

```
config>service>vprn>ospf>area>loopfree-alternate-exclude
```

```
config>service>vprn>ospf>area>interface>loopfree-alternate-exclude
```

---

### ECMP Considerations

Whenever the SPF computation determined there is more than one primary next-hop for a prefix, it will not program any LFA next-hop in RTM. Thus, IP prefixes will resolve to the multiple primary next-hops in this case which provides the required protection.

---

### IP FRR and RSVP Shortcut (IGP Shortcut)

IGP shortcuts are not supported in the LFA next-hop calculation.

## OSPF and IS-IS Support for Loop-Free Alternate Calculation

SPF computation in IS-IS and OSPF is enhanced to compute LFA alternate routes for each learned prefix and populate it in RTM.

Figure 17 illustrates a simple network topology with point-to-point (P2P) interfaces and highlights three routes to reach router R5 from router R1.

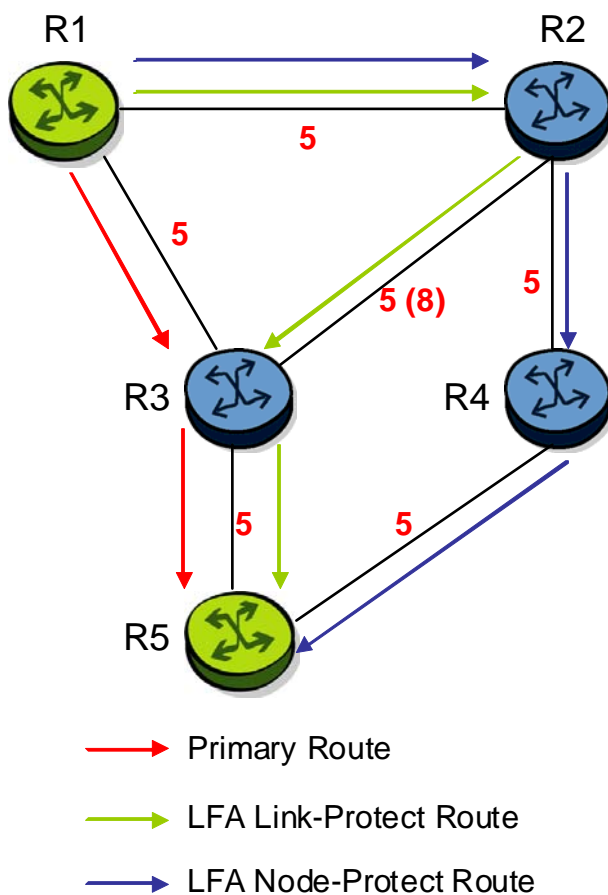

**Figure 17: Example Topology with Primary and LFA Routes**

The primary route is via R3. The LFA route via R2 has two equal cost paths to reach R5. The path via R3 protects against failure of link R1-R3. This route is computed by R1 by checking that the cost for R2 to reach R5 via R3 is lower than the cost via routes R1 and R3. This condition is referred to as the “loop-free criterion”.

The path via R2 and R4 can be used to protect against the failure of router R3. However, with the link R2-R3 metric set to 5, R2 sees the same cost to forward a packet to R5 via R3 and R4. Thus R1 cannot guarantee that enabling the LFA next-hop R2 will protect against R3 node failure. This

means that the LFA next-hop R2 provides link-protection only for prefix R5. If the metric of link R2-R3 is changed to 8, then the LFA next-hop R2 provides node protection since a packet to R5 will always go over R4.

Consider now the case where the primary next-hop uses a broadcast interface as illustrated in Figure 18.

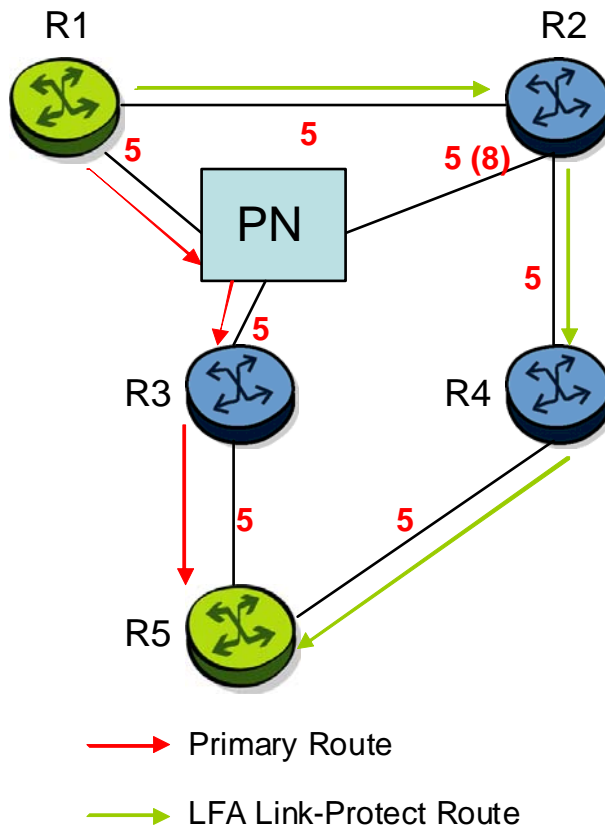

**Figure 18: Example Topology with Broadcast Interfaces**

In order for next-hop R2 to be a link-protect LFA for route R5 from R1, it must be loop-free with respect to the R1-R3 link's Pseudo-Node (PN). However, since R2 has also a link to that PN, its cost to reach R5 via the PN or router R4 are the same. Thus R1 cannot guarantee that enabling the LFA next-hop R2 will protect against a failure impacting link R1-PN since this may cause the entire subnet represented by the PN to go down. If the metric of link R2-PN is changed to 8, then R2 next-hop will be an LFA providing link protection.



The following are the detailed equations for this criterion as provided in RFC 5286, *Basic Specification for IP Fast Reroute: Loop-Free Alternates*:

- Link-protect backup next-hop (primary next-hop R1-R3 is a P2P interface):  

$$\text{Distance\_opt}(R2, R5) < \text{Distance\_opt}(R2, R1) + \text{Distance\_opt}(R1, R5)$$
- Node-protect backup next-hop (primary next-hop R1-R3 is a P2P interface):  

$$\text{Distance\_opt}(R2, R5) < \text{Distance\_opt}(R2, R3) + \text{Distance\_opt}(R3, R5)$$
- Link-protect backup next-hop (primary next-hop R1-R3 is a broadcast interface):  

$$\text{Distance\_opt}(R2, R5) < \text{Distance\_opt}(R2, \text{PN}) + \text{Distance\_opt}(\text{PN}, R5)$$

Where PN stands for the R1-R3 link's Pseudo-Node.

For the case of P2P interface, if SPF finds multiple LFA next-hops for a given primary next-hop, it follows the following selection algorithm:

- A) It will pick the node-protect type in favor of the link-protect type.
- B) If there is more than one LFA next-hop within the selected type, then it will pick one based on the least cost.
- C) If more than one LFA next-hop with the same cost results from step (b), then SPF will select the first one. This is not a deterministic selection and will vary following each SPF calculation.

For the case of a broadcast interface, a node-protect LFA is not necessarily a link protect LFA if the path to the LFA next-hop goes over the same PN as the primary next-hop. Similarly, a link protect LFA may not guarantee link protection if it goes over the same PN as the primary next-hop. The selection algorithm when SPF finds multiple LFA next-hops for a given primary next-hop is modified as follows:

- A) The algorithm splits the LFA next-hops into two sets:
  - The first set consists of LFA next-hops which do not go over the PN used by primary next-hop,
  - The second set consists of LFA next-hops which go over the PN used by the primary next-hop.
- B) If there is more than one LFA next-hop in the first set, it will pick the node-protect type in favor of the link-protect type.
- C) If there is more than one LFA next-hop within the selected type, then it will pick one based on the least cost.
- D) If more than one LFA next-hop with equal cost results from step (c), SPF will select the first one from the remaining set. This is not a deterministic selection and will vary following each SPF calculation.

E) If no LFA next-hop results from step (d), SPF will rerun steps (b-d) using the second set.

Note this algorithm is more flexible than strictly applying the link protect rule in the presence of a PN and specified in 5286. A node-protect LFA which does not avoid the PN, i.e., does not guarantee link protection, can still be selected as a last resort. The same thing, a link-protect LFA which does not avoid the PN may still be selected as a last resort.

---

### **Loop-Free Alternate Calculation for Inter-Area/inter-Level Prefixes**

When SPF resolves OSPF inter-area prefixes or IS-IS inter-level prefixes, it will compute an LFA backup next-hop to the same exit area/border router as used by the primary next-hop.

## IS-IS Configuration Process Overview

Figure 19 displays the process to provision basic IS-IS parameters.

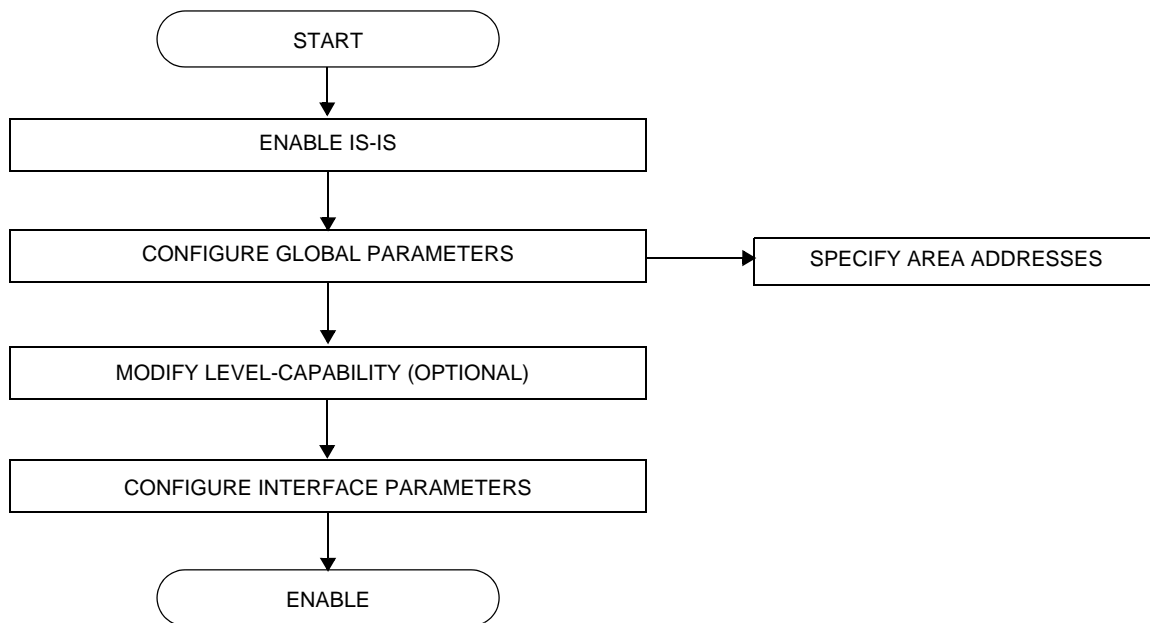

Figure 19: IS-IS Configuration and Implementation Flow

## Configuration Notes

This section describes IS-IS configuration caveats.

---

### General

- IS-IS must be enabled on each participating SR-Series .
- There are no default network entity titles.
- There are no default interfaces.
- By default, SR-Series routers are assigned a Level 1/Level 2 level capability.

## Configuring IS-IS with CLI

This section provides information to configure intermediate-system-to-intermediate-system (IS-IS) using the command line interface.

Topics in this section include:

- [IS-IS Configuration Overview on page 462](#)
  - [Router Levels on page 462](#)
  - [Area Address Attributes on page 462](#)
  - [Interface Level Capability on page 463](#)
  - [Route Leaking on page 464](#)
- [Basic IS-IS Configuration on page 465](#)
- [Common Configuration Tasks on page 467](#)
  - [Enabling IS-IS on page 468](#)
  - [Modifying Router-Level Parameters on page 468](#)
  - [Configuring ISO Area Addresses on page 470](#)
  - [Configuring Global IS-IS Parameters on page 471](#)
  - [Configuring Interface Parameters on page 476](#)
- [IS-IS Configuration Management Tasks on page 481](#)
  - [Disabling IS-IS on page 481](#)
  - [Modifying Global IS-IS Parameters on page 482](#)
  - [Modifying IS-IS Interface Parameters on page 483](#)
  - [Example: Configuring a Level 1 Area on page 478](#)
  - [Example: Modifying a Router's Level Capability on page 480](#)
  - [Configuring Leaking on page 485](#)
  - [Redistributing External IS-IS Routers on page 488](#)
  - [Specifying MAC Addresses for All IS-IS Routers on page 489](#)

## IS-IS Configuration Overview

---

### Router Levels

The router's level capability can be configured globally and on a per-interface basis. The interface-level parameters specify the interface's routing level. The neighbor capability and parameters define the adjacencies that are established.

IS-IS is not enabled by default. When IS-IS is enabled, the global default level capability is Level 1/2 which enables the router to operate as either a Level 1 and/or a Level 2 router with the associated databases. The router runs separate shortest path first (SPF) calculations for the Level 1 area routing and for the Level 2 multi-area routing to create the IS-IS routing table.

The level value can be modified on both or either of the global and interface levels to be only Level 1-capable, only Level 2-capable or Level 1 *and* Level 2-capable.

If the default value is not modified on any routers in the area, then the routers try to form both Level 1 and Level 2 adjacencies on all IS-IS interfaces. If the default values are modified to Level 1 or Level 2, then the number of adjacencies formed are limited to that level only.

---

### Area Address Attributes

The `area-id` command specifies the area address portion of the NET which is used to define the IS-IS area to which the router will belong. At least one `area-id` command should be configured on each router participating in IS-IS. A maximum of three `area-id` commands can be configured per router.

The area address identifies a point of connection to the network, such as a router interface, and is called a *network service access point (NSAP)*. The routers in an area manage routing tables about destinations within the area. The Network Entity Title (NET) value is used to identify the IS-IS area to which the router belongs.

NSAP addresses are divided into three parts. Only the Area ID portion is configurable.

1. Area ID — A variable length field between 1 and 13 bytes long. This includes the Authority and Format Identifier (AFI) as the most significant byte and the area ID.
2. System ID — A six-byte system identification. This value is not configurable. The system ID is derived from the system or router ID.
3. Selector ID — A one-byte selector identification that must contain zeros when configuring a NET. This value is not configurable. The selector ID is always 00.

The following example displays ISO addresses in IS-IS address format:

```
MAC address 00:a5:c7:6b:c4:90 49.0011.00a5.c76b.c490.00
IP address: 218.112.14.5 49.0011.2181.1201.4005.00
```

## Interface Level Capability

The level capability value configured on the interface level is compared to the level capability value configured on the global level to determine the type of adjacencies that can be established. The default level capability for 7750 SR-Series routers and interfaces is Level 1/2.

[Table 12](#) displays configuration combinations and the potential adjacencies that can be formed.

**Table 12: Potential Adjacency Capabilities**

| Global Level | Interface Level | Potential Adjacency    |
|--------------|-----------------|------------------------|
| L 1/2        | L 1/2           | Level 1 and/or Level 2 |
| L 1/2        | L 1             | Level 1 only           |
| L 1/2        | L 2             | Level 2 only           |
| L 2          | L 1/2           | Level 2 only           |
| L 2          | L 2             | Level 2 only           |
| L 2          | L 1             | none                   |
| L 1          | L 1/2           | Level 1 only           |
| L 1          | L 2             | none                   |
| L 1          | L 1             | Level 1 only           |

## Route Leaking

Alcatel-Lucent's implementation of IS-IS route leaking is performed in compliance with RFC 2966, *Domain-wide Prefix Distribution with Two-Level IS-IS*. As previously stated, IS-IS is a routing domain (an autonomous system running IS-IS) which can be divided into Level 1 areas with a Level 2-connected subset (backbone) of the topology that interconnects all of the Level 1 areas. Within each Level 1 area, the routers exchange link state information. Level 2 routers also exchange Level 2 link state information to compute routes between areas.

Routers in a Level 1 area typically only exchange information within the Level 1 area. For IP destinations not found in the prefixes in the Level 1 database, the Level 1 router forwards PDUs to the nearest router that is in both Level 1/Level 2 with the *attached bit* set in its Level 1 link-state PDU.

There are many reasons to implement domain-wide prefix distribution. The goal of domain-wide prefix distribution is to increase the granularity of the routing information within the domain. The routing mechanisms specified in RFC 1195 are appropriate in many situations and account for excellent scalability properties. However, in certain circumstances, the amount of scalability can be adjusted which can distribute more specific information than described by RFC 1195.

Distributing more prefix information can improve the quality of the resulting routes. A well known property of default routing is that loss of information can occur. This loss of information affects the computation of a route based upon less information which can result in sub-optimal routes.



## Basic IS-IS Configuration

For IS-IS to operate on 7750 SR-Series routers, IS-IS must be explicitly enabled, and at least one area address and interface must be configured. If IS-IS is enabled but no area address or interface is defined, the protocol is enabled but no routes are exchanged. When at least one area address and interface are configured, then adjacencies can be formed and routes exchanged.

To configure IS-IS, perform the following tasks:

- Enable IS-IS.
- If necessary, modify the level capability on the global level (default is level-1/2).
- Define area address(es)
- Configure IS-IS interfaces.

The following output displays IS-IS default values.

```
A:Dut-A>config>router>isis$ info detail
```

```

level-capability level-1/2
no graceful-restart
area-id 01
no authentication-key
no authentication-type
authentication-check
csnp-authentication
lsp-lifetime 1200
no export
hello-authentication
psnp-authentication
traffic-engineering
no reference-bandwidth
no disable-ldp-sync
ipv4-routing
no ipv6-routing
no unicast-import-disable
no multicast-import
spf-wait 10 1000 1000
no strict-adjacency-check
lsp-wait 5 0 1
level 1
 no authentication-key
 no authentication-type
 csnp-authentication
 external-preference 160
 hello-authentication
 preference 15
 psnp-authentication
 no wide-metrics-only
exit
level 2
 no authentication-key
 no authentication-type
```

## Basic IS-IS Configuration

```
 csnp-authentication
 external-preference 165
 hello-authentication
 preference 18
 psnp-authentication
 no wide-metrics-only
 exit
 no shutdown

A:Dut-A>config>router>isis$
```

## Common Configuration Tasks

To implement IS-IS in your network, you must enable IS-IS on each participating 7750 SR-Series router.

To assign different level capabilities to the routers and organize your network into areas, modify the level capability defaults on end systems from Level 1/2 to Level 1. Routers communicating to other areas can retain the Level 1/2 default.

On each router, at least one area ID also called the area address should be configured as well as at least one IS-IS interface.

- Enable IS-IS.
- Configure global IS-IS parameters.
  - Configure area address(es).
- Configure IS-IS interface-specific parameters.

## Configuring IS-IS Components

Use the CLI syntax displayed below for:

- [Enabling IS-IS on page 468](#)
  - [Modifying Router-Level Parameters on page 468](#)
  - [Configuring ISO Area Addresses on page 470](#)
  - [Configuring Global IS-IS Parameters on page 471](#)
  - [Configuring Interface Parameters on page 476](#)
  - [Example: Configuring a Level 1 Area on page 478](#)
  - [Example: Modifying a Router's Level Capability on page 480](#)
- 

### Enabling IS-IS

IS-IS must be enabled in order for the protocol to be active.

**NOTE:** Careful planning is essential to implement commands that can affect the behavior of global and interface levels.

To configure IS-IS on a router, enter the following command:

**CLI Syntax:** `isis`

**Example:** `config>router# isis`

---

### Modifying Router-Level Parameters

When IS-IS is enabled, the default `level-capability` is Level 1/2. This means that the router operates with both Level 1 and Level 2 routing capabilities. To change the default value in order for the router to operate as a Level 1 router or a Level 2 router, you must explicitly modify the `level` value.

If the level is modified, the protocol shuts down and restarts. Doing this can affect adjacencies and routes.

The `level-capability` value can be configured on the global level and also on the interface level. The `level-capability` value determines which level values can be assigned on the router level or on an interface-basis.

In order for the router to operate as a Level 1 only router or as a Level 2 only router, you must explicitly specify the *level-number* value.

- Select `level-1` to route only within an area.
- Select `level-2` to route to destinations outside an area, toward other eligible Level 2 routers.

To configure the router level, enter the following commands:

**CLI Syntax:** `config>router# isis`  
`level-capability {level-1|level-2|level-1/2}`  
`level {1|2}`

**Example:** `config>router# isis`  
`config>router>isis# level-capability 1/2`  
`config>router>isis# level 2`

The following example displays the configuration:

```
A:ALA-A>config>router>isis# info
#-----
echo "ISIS"
#-----

 level-capability level-1/2
 level 2

A:ALA-A>config>router>isis#
```

## Configuring ISO Area Addresses

Use the following CLI syntax to configure an area ID also called an address. A maximum of 3 area-id can be configured.

**CLI Syntax:** config>router# isis  
                  area-id area-address

The following example configures the router's area ID:

**Example:** config>router>isis#  
              config>router>isis# area-id 49.0180.0001  
              config>router>isis# area-id 49.0180.0002  
              config>router>isis# area-id 49.0180.0003

The following example displays the area ID configuration:

```
A:ALA-A>config>router>isis# info

 area-id 49.0180.0001
 area-id 49.0180.0002
 area-id 49.0180.0003

A:ALA-A>config>router>isis#
```

## Configuring Global IS-IS Parameters

Commands and parameters configured on the global level are inherited to the interface levels. Parameters specified in the interface and interface-level configurations take precedence over global configurations.

The following example displays global-level IS-IS configuration command usage:

```
Example: config>router# isis
 config>router>isis#
 config>router>isis# level-capability level-2
 config>router>isis# authentication-check
 config>router>isis# authentication-type password
 config>router>isis# authentication-key test
 config>router>isis# overload timeout 90
 config>router>isis# traffic-engineering
```

The following example displays the modified global-level configuration.

```
A:ALA-A>config>router>isis# info

 level-capability level-2
 area-id 49.0180.0001
 area-id 49.0180.0002
 area-id 49.0180.0003
 authentication-key "H5KBAWrAAQU" hash
 authentication-type password
 overload timeout 90
 traffic-engineering

A:ALA-A>config>router>isis#
```

## Migration to IS-IS Multi-Topology

To migrate to IS-IS multi-topology for IPv6, perform the following tasks:

Enable the sending/receiving of IPv6 unicast reachability information in IS-IS MT TLVs on all the routers that support MT.

**CLI Syntax:** config>router# isis  
multi-topology  
ipv6-unicast

```
A:ALA-49>config>router>isis# info detail

...
 ipv4-routing
 ipv6-routing native
 multi-topology
 ipv6-unicast
 exit
...

A:ALA-49>config>router>isis#
```

Ensure that all MT routers have the IPv6 reachability information required by MT TLVs:

**CLI Syntax:** show>router# isis  
topology ipv6-unicast

```
A:ALA-49>config>router>isis# show router isis topology ipv6-unicast
=====
Topology Table
=====
Node Interface Nexthop

No Matching Entries
=====
A:ALA-49>config>router>isis#
```



**CLI Syntax:** show>router# isis  
database detail

```
A:ALA-49>config>router>isis# show router isis database detail
=====
ISIS Database
=====
Displaying Level 1 database

LSP ID : ALA-49.00-00 Level : L1
Sequence : 0x22b Checksum : 0x60e4 Lifetime : 1082
Version : 1 Pkt Type : 18 Pkt Ver : 1
Attributes: L1L2 Max Area : 3
SysID Len : 6 Used Len : 404 Alloc Len : 1492

TLVs :
Area Addresses :
 Area Address : (13) 47.4001.8000.00a7.0000.ffdd.0007
Supp Protocols :
 Protocols : IPv4 IPv6
IS-Hostname :
 Hostname : ALA-49
TE Router ID :
 Router ID : 10.10.10.104
Internal Reach :
 IP Prefix : 10.10.10.104/32 (Dir. :Up) Metric : 0 (I)
 IP Prefix : 10.10.4.0/24 (Dir. :Up) Metric : 10 (I)
 IP Prefix : 10.10.5.0/24 (Dir. :Up) Metric : 10 (I)
 IP Prefix : 10.10.7.0/24 (Dir. :Up) Metric : 10 (I)
 IP Prefix : 10.10.0.0/24 (Dir. :Up) Metric : 10 (I)
 IP Prefix : 10.0.0.0/24 (Dir. :Up) Metric : 10 (I)
MT IPv6 Reach. :
 MT ID : 2
 IPv6 Prefix : 3ffe::101:100/120
 Flags : Up Internal Metric : 10
 IPv6 Prefix : 10::/64
 Flags : Up Internal Metric : 10
I/f Addresses :
 IP Address : 10.10.10.104
 IP Address : 10.10.4.3
 IP Address : 10.10.5.3
 IP Address : 10.10.7.3
 IP Address : 10.10.0.16
 IP Address : 10.0.0.104
I/f Addresses IPv6 :
 IPv6 Address : 3FFE::101:101
 IPv6 Address : 10::104
TE IP Reach. :
 IP Prefix : 10.10.10.104/32 (Dir. :Up) Metric : 0
 IP Prefix : 10.10.4.0/24 (Dir. :Up) Metric : 10
 IP Prefix : 10.10.5.0/24 (Dir. :Up) Metric : 10
 IP Prefix : 10.10.7.0/24 (Dir. :Up) Metric : 10
 IP Prefix : 10.10.0.0/24 (Dir. :Up) Metric : 10
 IP Prefix : 10.0.0.0/24 (Dir. :Up) Metric : 10
Authentication :
```

## Configuring IS-IS Components

```
Auth Type : Password(1) (116 bytes)

Level (1) LSP Count : 1

Displaying Level 2 database

LSP ID : ALA-49.00-00 Level : L2
Sequence : 0x22c Checksum : 0xb888 Lifetime : 1082
Version : 1 Pkt Type : 20 Pkt Ver : 1
Attributes: L1L2 Max Area : 3
SysID Len : 6 Used Len : 304 Alloc Len : 1492

TLVs :
Area Addresses :
 Area Address : (13) 47.4001.8000.00a7.0000.ffdd.0007
Supp Protocols :
 Protocols : IPv4 IPv6
IS-Hostname :
 Hostname : ALA-49
TE Router ID :
 Router ID : 10.10.10.104
Internal Reach :
 IP Prefix : 10.10.10.104/32 (Dir. :Up) Metric : 0 (I)
 IP Prefix : 10.10.4.0/24 (Dir. :Up) Metric : 10 (I)
 IP Prefix : 10.10.5.0/24 (Dir. :Up) Metric : 10 (I)
 IP Prefix : 10.10.7.0/24 (Dir. :Up) Metric : 10 (I)
 IP Prefix : 10.10.0.0/24 (Dir. :Up) Metric : 10 (I)
 IP Prefix : 10.0.0.0/24 (Dir. :Up) Metric : 10 (I)
MT IPv6 Reach. :
 MT ID : 2
 IPv6 Prefix : 3ffe::101:100/120
 Flags : Up Internal Metric : 10
 IPv6 Prefix : 10::/64
 Flags : Up Internal Metric : 10
I/f Addresses :
 IP Address : 10.10.10.104
 IP Address : 10.10.4.3
 IP Address : 10.10.5.3
 IP Address : 10.10.7.3
 IP Address : 10.10.0.16
 IP Address : 10.0.0.104
I/f Addresses IPv6 :
 IPv6 Address : 3FFE::101:101
 IPv6 Address : 10::104
TE IP Reach. :
 IP Prefix : 10.10.10.104/32 (Dir. :Up) Metric : 0
 IP Prefix : 10.10.4.0/24 (Dir. :Up) Metric : 10
 IP Prefix : 10.10.5.0/24 (Dir. :Up) Metric : 10
 IP Prefix : 10.10.7.0/24 (Dir. :Up) Metric : 10
 IP Prefix : 10.10.0.0/24 (Dir. :Up) Metric : 10
 IP Prefix : 10.0.0.0/24 (Dir. :Up) Metric : 10
Authentication :
 Auth Type : MD5(54) (16 bytes)

Level (2) LSP Count : 1
=====
A:ALA-49>config>router>isis#
```

Configure MT TLVs for IPv6 SPF:

**CLI Syntax:** config>router# isis  
ipv6-routing mt

```
A:ALA-49>config>router>isis# info detail

...
 ipv4-routing
 ipv6-routing mt
 multi-topology
 ipv6-unicast
 exit
...

A:ALA-49>config>router>isis#
```

Verify IPv6 routes:

**CLI Syntax:** show>router# isis  
routes ipv6-unicast

```
A:ALA-49>config>router>isis# show router isis routes ipv6-unicast
=====
Route Table
=====
Prefix Metric Lvl/Typ Ver. SysID/Hostname
 NextHop MT

No Matching Entries
=====
A:ALA-49>config>router>isis#
```

**CLI Syntax:** show>router# route-table ipv6

```
A:ALA-48>show>router# route-table ipv6
=====
IPv6 Route Table (Router: Base)
=====
Dest Prefix Type Proto Age Pref
 Next Hop[Interface Name] Metric

10::/64 Local Local 05h35m28s 0
 to-104 0

No. of Routes: 1
=====
A:ALA-48>show>router#
```

### Configuring Interface Parameters

There are no interfaces associated with IS-IS by default. An interface belongs to all areas configured on a router. Interfaces cannot belong to separate areas. There are no default interfaces applied to the router's IS-IS instance. You must configure at least one IS-IS interface in order for IS-IS to work.

To enable IS-IS on an interface, first configure an IP interface in the `config>router>interface` context. Then, apply the interface in the `config>router>isis>interface` context.

You can configure both the Level 1 parameters and the Level 2 parameters on an interface. The `level-capability` value determines which level values are used.

NOTE: For point-to-point interfaces, only the values configured under Level 1 are used regardless of the operational level of the interface.

The following example displays the modified interface parameters:

```
Example: config>router# isis
 config>router>isis# level 1
 config>router>isis>level# wide-metrics-only
 config>router>isis>level# exit
 config>router>isis# level 2
 config>router>isis>level# wide-metrics-only
 config>router>isis>level# exit
 config>router>isis# interface ALA-1-2
 config>router>isis>if# level-capability level-2
 config>router>isis>if# mesh-group 85
 config>router>isis>if# exit
 config>router>isis# interface ALA-1-3
 config>router>isis>if# level-capability level-1
 config>router>isis>if# interface-type point-to-point
 config>router>isis>if# mesh-group 101
 config>router>isis>if# exit
 config>router>isis# interface ALA-1-5
 config>router>isis>if# level-capability level-1
 config>router>isis>if# interface-type point-to-point
 config>router>isis>if# mesh-group 85
 config>router>isis>if# exit
 config>router>isis# interface to-103
 config>router>isis>if# level-capability level-1/2
 >router>isis>if# mesh-group 101
 config>router>isis>if# exit
 config>router>isis#
```

The following example displays the global and interface-level configurations.

```
A:ALA-A>config>router>isis# info

level-capability level-2
area-id 49.0180.0001
area-id 49.0180.0002
area-id 49.0180.0003
authentication-key "H5KBAWrAAQU" hash
authentication-type password
traffic-engineering
level 1
 wide-metrics-only
exit
level 2
 wide-metrics-only
exit
interface "system"
exit
interface "ALA-1-2"
 level-capability level-2
 mesh-group 85
exit
interface "ALA-1-3"
 level-capability level-1
 interface-type point-to-point
 mesh-group 101
exit
interface "ALA-1-5"
 level-capability level-1
 interface-type point-to-point
 mesh-group 85
exit
interface "to-103"
 mesh-group 101
exit

A:ALA-A>config>router>isis#
```

## Example: Configuring a Level 1 Area

**NOTE:** Interfaces are configured in the `config>router>interface` context.

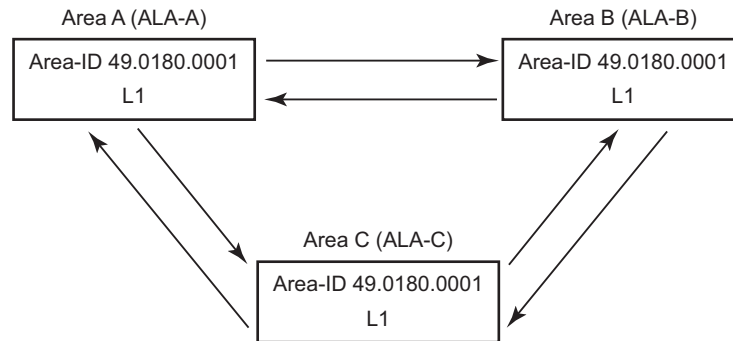

OSRG031

**Figure 20: Configuring a Level 1 Area**

The following example displays the command usage to configure a Level 1 area.

```
A:ALA-A>config>router# isis
A:ALA-A>config>router>isis# area-id 47.0001
A:ALA-A>config>router>isis# level-capability level-1
A:ALA-A>config>router>isis# interface system
A:ALA-A>config>router>isis>if# exit
A:ALA-A>config>router>isis# interface A-B
A:ALA-A>config>router>isis>if# exit
A:ALA-A>config>router>isis# interface A-C
A:ALA-A>config>router>isis>if# exit
A:ALA-A>config>router>isis#
```

```
A:ALA-B>config>router# isis
A:ALA-B>config>router>isis# area-id 47.0001
A:ALA-B>config>router>isis# level-capability level-1
A:ALA-B>config>router>isis# interface system
A:ALA-B>config>router>isis>if# exit
A:ALA-B>config>router>isis# interface B-A
A:ALA-B>config>router>isis>if# exit
A:ALA-B>config>router>isis# interface B-C
A:ALA-B>config>router>isis>if# exit
A:ALA-B>config>router>isis#
```

```
A:ALA-C>config>router# isis
A:ALA-C>config>router>isis# area-id 47.0001
A:ALA-C>config>router>isis# level-capability level-1
A:ALA-C>config>router>isis# interface system
```

```
A:ALA-C>config>router>isis>if# exit
A:ALA-C>config>router>isis# interface "C-A"
A:ALA-C>config>router>isis>if# exit
A:ALA-C>config>router>isis# interface "C-B"
A:ALA-C>config>router>isis>if# exit
```

```
A:ALA-A>config>router>isis# info

level-capability level-1
area-id 49.0180.0001
interface "system"
exit
interface "A-B"
exit
interface "A-C"
exit

```

```
A:ALA-A>config>router>isis#
```

```
A:ALA-B>config>router>isis# info

level-capability level-1
area-id 49.0180.0001
interface "system"
exit
interface "B-A"
exit
interface "B-C"
exit

```

```
A:ALA-B>config>router>isis#
```

```
A:ALA-C>config>router>isis# info
#-----
echo "ISIS"

level-capability level-1
area-id 49.0180.0001
interface "system"
exit
interface "C-A"
exit
interface "C-B"
exit

```

```
A:ALA-C>config>router>isis#
```

### Example: Modifying a Router's Level Capability

In the previous example, ALA-A, ALA-B, and ALA-C are configured as Level 1 systems. Level 1 systems communicate with other Level 1 systems in the same area. In this example, ALA-A is modified to set the level capability to Level 1/2. Now, the Level 1 systems in the area with NET 47.0001 forward PDUs to ALA-A for destinations that are not in the local area.

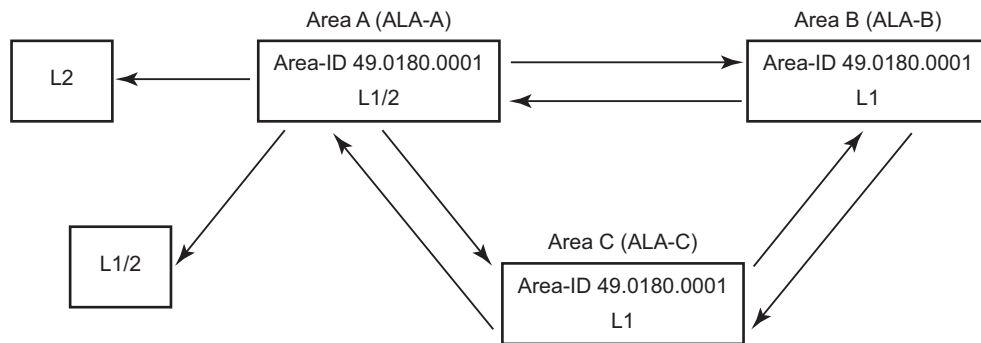

OSRG036

**Figure 21: Configuring a Level 1/2 Area**

The following example displays the command usage to configure a Level 1/2 system.

```
A:ALA-A>config>router# isis
A:ALA-A>config>router>isis# level-capability level-1/2
```



## IS-IS Configuration Management Tasks

This section discusses the following IS-IS configuration management tasks:

- [Disabling IS-IS on page 481](#)
  - [Removing IS-IS on page 481](#)
  - [Modifying Global IS-IS Parameters on page 482](#)
  - [Modifying IS-IS Interface Parameters on page 483](#)
    - [Example: Configuring a Level 1 Area on page 478](#)
    - [Example: Modifying a Router's Level Capability on page 480](#)
  - [Configuring Leaking on page 485](#)
  - [Redistributing External IS-IS Routers on page 488](#)
  - [Specifying MAC Addresses for All IS-IS Routers on page 489](#)
- 

### Disabling IS-IS

The `shutdown` command disables the IS-IS protocol instance on the router. The configuration settings are not changed, reset, or removed.

To disable IS-IS on a router, enter the following commands:

**CLI Syntax:** `config>router# isis  
shutdown`

---

### Removing IS-IS

The `no isis` command deletes the IS-IS protocol instance. The IS-IS configuration reverts to the default settings.

To remove the IS-IS configuration enter the following commands:

**CLI Syntax:** `config>router#  
no isis`

### Modifying Global IS-IS Parameters

You can modify, disable, or remove global IS-IS parameters without shutting down entities. Changes take effect immediately. Modifying the level capability on the global level causes the IS-IS protocol to restart.

The following example displays command usage to modify various parameters:

```
Example: config>router>isis# overload timeout 500
 config>router>isis# level-capability level-1/2
 config>router>isis# no authentication-check
 config>router>isis# authentication-key raiderslost
```

The following example displays the global modifications

```
A:ALA-A>config>router>isis# info

 area-id 49.0180.0001
 area-id 49.0180.0002
 area-id 49.0180.0003
 authentication-key "//oZrvtvFPn06S42lRIJSE" hash
 authentication-type password
 no authentication-check
 overload timeout 500 on-boot
 level 1
 wide-metrics-only
 exit
 level 2
 wide-metrics-only
 exit
 interface "system"
 exit
 interface "ALA-1-2"
 level-capability level-2
 mesh-group 85
 exit
 interface "ALA-1-3"
 level-capability level-1
 interface-type point-to-point
 mesh-group 101
 exit
 interface "ALA-1-5"
 level-capability level-1
 interface-type point-to-point
 mesh-group 85
 exit
 interface "to-103"
 mesh-group 101
 exit
 interface "A-B"
 exit
 interface "A-C"
 exit

A:ALA-A>config>router>isis#
```

## Modifying IS-IS Interface Parameters

You can modify, disable, or remove interface-level IS-IS parameters without shutting down entities. Changes take effect immediately. Modifying the level capability on the interface causes the IS-IS protocol on the interface to restart.

To remove an interface, issue the `no interface ip-int-name` command.  
To disable an interface, issue the `shutdown` command in the interface context.

The following example displays interface IS-IS modification command usage:

```
Example:config>router# isis
config>router>isis# interface ALA-1-3
config>router>isis>if# mesh-group 85
config>router>isis>if# passive
config>router>isis>if# lsp-pacing-interval 5000
config>router>isis>if# exit
config>router>isis# interface to-103
config>router>isis>if# hello-authentication-type message-digest
config>router>isis>if# hello-authentication-key 49ersrule
config>router>isis>if# exit
```

The following example displays the modified interface parameters.

```
A:ALA-A>config>router>isis# info

area-id 49.0180.0001
area-id 49.0180.0002
area-id 49.0180.0003
authentication-key "//oZrvtvFPn06S42lRIJSE" hash
authentication-type password
no authentication-check
overload timeout 500 on-boot
level 1
 wide-metrics-only
exit
level 2
 wide-metrics-only
exit
interface "system"
exit
interface "ALA-1-2"
 level-capability level-2
 mesh-group 85
exit
interface "ALA-1-3"
 level-capability level-1
 interface-type point-to-point
 lsp-pacing-interval 5000
 mesh-group 85
 passive
exit
interface "ALA-1-5"
```

## IS-IS Configuration Management Tasks

```
 level-capability level-1
 interface-type point-to-point
 mesh-group 85
 exit
 interface "to-103"
 hello-authentication-key "DvR31264KQ6vXMTvbAZ1mE" hash
 hello-authentication-type message-digest
 mesh-group 101
 exit
 interface "A-B"
 exit

A:ALA-A>config>router>isis#
```

## Configuring Leaking

IS-IS allows a two-level hierarchy to route PDUs. Level 1 areas can be interconnected by a contiguous Level 2 backbone.

The Level 1 link-state database contains information only about that area. The Level 2 link-state database contains information about the Level 2 system and each of the Level 1 systems in the area. A Level 1/2 router contains information about both Level 1 and Level 2 databases. A Level 1/2 router advertises information about its Level 1 area toward the other Level 1/2 or Level 2 (only) routers.

Packets with destinations outside the Level 1 area are forwarded toward the closest Level 1/2 router which, in turn, forwards the packets to the destination area.

Sometimes, the shortest path to an outside destination is not through the closest Level 1/2 router, or, the only Level 1/2 system to forward packets out of an area is not operational. Route leaking provides a mechanism to leak Level 2 information to Level 1 systems to provide routing information regarding inter-area routes. Then, a Level 1 router has more options to forward packets.

Configure a route policy to leak routes from Level 2 into Level 1 areas in the `config>router>policy-options>policy-statement` context.

The following example shows the command usage to configure prefix list and policy statement parameters in the `config>router` context.

```
config>router>policy-options# prefix-list loops
..>policy-options>prefix-list# prefix 10.1.1.0/24 longer
..>policy-options>prefix-list# exit
..>policy-options# policy-statement leak
..>policy-options>policy-statement# entry 10
..>policy-options>policy-statement>entry# from
..>policy-options>policy-statement>entry>from# prefix-list loops
..>policy-options>policy-statement>entry>from# level 2
..>policy-options>policy-statement>entry>from# exit
..>policy-options>policy-statement>entry# to
..>policy-options>policy-statement>entry>to# level 1
..>policy-options>policy-statement>entry>to# exit
..>policy-options>policy-statement>entry# action accept
..>policy-options>policy-statement>entry>action# exit
..>policy-options>policy-statement>entry# exit
..>policy-options>policy-statement#exit
..>policy-options# commit
..>policy-options#
```

## IS-IS Configuration Management Tasks

```
A:ALA-A>config>router>policy-options# info

prefix-list "loops"
 prefix 10.1.1.0/24 longer
exit
policy-statement "leak"
 entry 10
 from
 prefix-list "loop"
 level 2
 exit
 to
 level 1
 exit
 action accept
 exit
 exit
exit
exit

A:ALA-A>config>router>policy-options#
```

Next, apply the policy to leak routes from Level 2 into Level 1 systems on ALA-A.

```
config>router#isis
config>router>isis# export leak
```

```
A:ALA-A>config>router>isis# info

area-id 49.0180.0001
area-id 49.0180.0002
area-id 49.0180.0003
authentication-key "//oZrvtvFPn06S42lRIJsE" hash
authentication-type password
no authentication-check
export "leak"
...

A:ALA-A>config>router>isis#
```

After the policy is applied, create a policy to redistribute external IS-IS routes from Level 1 systems into the Level 2 backbone (see [Redistributing External IS-IS Routers on page 488](#)). In the `config>router` context, configure the following policy statement parameters:

```
config>router>policy-options# begin
..>policy-options# policy-statement "isis-ext"
..>policy-options>policy-statement# entry 10
..>policy-options>policy-statement>entry$ from
..>policy-options>policy-statement>entry>from$ external
..>policy-options>policy-statement>entry>from# exit
..>policy-options>policy-statement>entry# to
..>policy-options>policy-statement>entry>to$ level 2
..>policy-options>policy-statement>entry>to# exit
..>policy-options>policy-statement>entry# action accept
..>policy-options>policy-statement>entry>action# exit
..>policy-options>policy-statement>entry# exit
..>policy-options>policy-statement# exit
..>policy-options# commit
```

```
A:ALA-A>config>router>policy-options# info
```

```

prefix-list "loops"
 prefix 10.1.1.0/24 longer
exit
policy-statement "leak"
 entry 10
 from
 prefix-list "loop"
 level 2
 exit
 to
 level 1
 exit
 action accept
 exit
 exit
exit
policy-statement "isis-ext"
 entry 10
 from
 external
 exit
 to
 level 2
 exit
 action accept
 exit
 exit
exit

```

```
A:ALA-A>config>router>policy-options#
```

### Redistributing External IS-IS Routers

IS-IS does not redistribute Level 1 external routes into Level 2 by default. You must explicitly apply the policy to redistribute external IS-IS routes. Policies are created in the `config>router>policy-options` context. Refer to the *Route Policy* section of this manual for more information.

The following example displays the policy statement configuration.

```
config>router>policy-options# info

 prefix-list "loops"
 prefix 10.1.1.0/24 longer
 exit
 policy-statement "leak"
 entry 10
 from
 prefix-list "loop"
 level 2
 exit
 to
 level 1
 exit
 action accept
 exit
 exit
 exit
 policy-statement "isis-ext"
 entry 10
 from
 external
 exit
 to
 level 2
 exit
 action accept
 exit
 exit
 exit

config>router>policy-options#
```



## Specifying MAC Addresses for All IS-IS Routers

Specify the MAC address to use for all L1 or L2 IS-IS routers. The following example shows how to specify all L1 routers:

**Example:** `all-l1isis 01-80-C2-00-00-14`

You can also specify the MAC address for all L2 IS-IS routers by using the **all-l2isis** command.



---

## IS-IS Configuration Commands

---

### Generic Commands

#### isis

**Syntax**    **isis** [*instance-id*]  
**no isis** [*instance-id*]

**Context**    config>router

**Description**    This command creates the context to configure the Intermediate-System-to-Intermediate-System (IS-IS) protocol instance.

The IS-IS protocol instance is enabled with the **no shutdown** command in the **config>router>isis** context. Alternatively, the IS-IS protocol instance is disabled with the **shutdown** command in the **config>router>isis** context.

The **no** form of the command deletes the IS-IS protocol instance. Deleting the protocol instance removes all configuration parameters for this IS-IS instance.

**Parameters**    *instance-id* — Specifies the instance ID for an IS-IS instance.

**Values**        1–31

**Default**        0

#### shutdown

**Syntax**    [**no**] **shutdown**

**Context**    config>router>isis  
config>router>isis>interface *ip-int-name*  
config>router>isis>if>level *level-number*

**Description**    This command administratively disables an entity. When disabled, an entity does not change, reset, or remove any configuration settings or statistics.

The operational state of the entity is disabled as well as the operational state of any entities contained within. Many objects must be shut down before they may be deleted.

The **no** form of this command administratively enables an entity.

**Special Cases**    **IS-IS Global** — In the **config>router>isis** context, the **shutdown** command disables the IS-IS protocol instance. By default, the protocol is enabled, **no shutdown**.

**IS-IS Interface** — In the **config>router>isis>interface** context, the command disables the IS-IS interface. By default, the IS-IS interface is enabled, **no shutdown**.

## Generic Commands

**IS-IS Interface and Level** — In the `config>router>isis>interface ip-int-name>level` context, the command disables the IS-IS interface for the level. By default, the IS-IS interface at the level is enabled, **no shutdown**.

**Default** **no shutdown** — IS-IS entity is administratively enabled.

### tag

**Syntax** **tag tag**  
**no tag**

**Context** config>router>isis>interface

**Description** This command configures a route tag to the specified IP address of an interface.

**Parameters** tag — [1..4294967295]

### all-l1isis

**Syntax** **all-l1isis ieee-address**  
**no all-l1isis**

**Context** config>router>isis

**Description** This command enables you to specify the MAC address to use for all L1 IS-IS routers. The MAC address should be a multicast address. You should shut/no shut the IS-IS instance to make the change operational.

**Default** all-l1isis 01-80-C2-00-01-00

**Parameters** *ieee-address* — Specifies the destination MAC address for all L1 I-IS neighbors on the link for this ISIS instance.

### all-l2isis

**Syntax** **all-l2isis ieee-address**  
**no all-l2isis**

**Context** config>router>isis

**Description** This command enables you to specify the MAC address to use for all L2 IS-IS routers. The MAC address should be a multicast address. You should shut/no shut the IS-IS instance to make the change operational.

**Default** all-l2isis 01-80-C2-00-02-11

**Parameters** *ieee-address* — Specifies the destination MAC address for all L2 ISIS neighbors on the link for this ISIS instance.

## authentication-check

|                    |                                                                                                                                                                                                                                                                                                                                                                                                                                                                                                                                                                                                                                     |
|--------------------|-------------------------------------------------------------------------------------------------------------------------------------------------------------------------------------------------------------------------------------------------------------------------------------------------------------------------------------------------------------------------------------------------------------------------------------------------------------------------------------------------------------------------------------------------------------------------------------------------------------------------------------|
| <b>Syntax</b>      | <b>[no] authentication-check</b>                                                                                                                                                                                                                                                                                                                                                                                                                                                                                                                                                                                                    |
| <b>Context</b>     | config>router>isis                                                                                                                                                                                                                                                                                                                                                                                                                                                                                                                                                                                                                  |
| <b>Description</b> | <p>This command sets an authentication check to reject PDUs that do not match the type or key requirements. The default behavior when authentication is configured is to reject all IS-IS protocol PDUs that have a mismatch in either the authentication type or authentication key.</p> <p>When <b>no authentication-check</b> is configured, authentication PDUs are generated and IS-IS PDUs are authenticated on receipt. However, mismatches cause an event to be generated and will not be rejected.</p> <p>The <b>no</b> form of this command allows authentication mismatches to be accepted and generate a log event.</p> |
| <b>Default</b>     | <b>authentication-check</b> — Rejects authentication mismatches.                                                                                                                                                                                                                                                                                                                                                                                                                                                                                                                                                                    |

## authentication-key

|                    |                                                                                                                                                                                                                                                                                                                                                                                                                                                                                                                                                                                                                                                                                                                                                                                                                                                                                                                                                                  |
|--------------------|------------------------------------------------------------------------------------------------------------------------------------------------------------------------------------------------------------------------------------------------------------------------------------------------------------------------------------------------------------------------------------------------------------------------------------------------------------------------------------------------------------------------------------------------------------------------------------------------------------------------------------------------------------------------------------------------------------------------------------------------------------------------------------------------------------------------------------------------------------------------------------------------------------------------------------------------------------------|
| <b>Syntax</b>      | <b>authentication-key</b> [ <i>authentication-key</i>   <i>hash-key</i> ] [ <b>hash</b>   <b>hash2</b> ]<br><b>no authentication-key</b>                                                                                                                                                                                                                                                                                                                                                                                                                                                                                                                                                                                                                                                                                                                                                                                                                         |
| <b>Context</b>     | config>router>isis<br>config>router>isis>level <i>level-number</i>                                                                                                                                                                                                                                                                                                                                                                                                                                                                                                                                                                                                                                                                                                                                                                                                                                                                                               |
| <b>Description</b> | <p>This command sets the authentication key used to verify PDUs sent by neighboring routers on the interface. Neighboring routers use passwords to authenticate PDUs sent from an interface. For authentication to work, both the authentication <i>key</i> and the authentication <i>type</i> on a segment must match. The <b>authentication-type</b> statement must also be included.</p> <p>To configure authentication on the global level, configure this command in the <b>config&gt;router&gt;isis</b> context. When this parameter is configured on the global level, all PDUs are authenticated including the hello PDU.</p> <p>To override the global setting for a specific level, configure the <b>authentication-key</b> command in the <b>config&gt;router&gt;isis&gt;level</b> context. When configured within the specific level, hello PDUs are not authenticated.</p> <p>The <b>no</b> form of the command removes the authentication key.</p> |
| <b>Default</b>     | <b>no authentication-key</b> — No authentication key is configured.                                                                                                                                                                                                                                                                                                                                                                                                                                                                                                                                                                                                                                                                                                                                                                                                                                                                                              |
| <b>Parameters</b>  | <p><i>authentication-key</i> — The authentication key. The key can be any combination of ASCII characters up to 255 characters in length (un-encrypted). If spaces are used in the string, enclose the entire string in quotation marks (“ ”).</p> <p><i>hash-key</i> — The hash key. The key can be any combination of ASCII characters up to 342 characters in length (encrypted). If spaces are used in the string, enclose the entire string in quotation marks (“ ”).</p> <p>This is useful when a user must configure the parameter, but, for security purposes, the actual unencrypted key value is not provided.</p> <p><b>hash</b> — Specifies the key is entered in an encrypted form. If the <b>hash</b> parameter is not used, the key is assumed to be in a non-encrypted, clear text form. For security, all keys are stored in encrypted form in the configuration file with the <b>hash</b> parameter specified.</p>                             |

## Generic Commands

**hash2** — Specifies the key is entered in a more complex encrypted form. If the **hash2** parameter is not used, the less encrypted **hash** form is assumed.

### authentication-type

|                    |                                                                                                                                                                                                                                                                                                                                                                                                                                                                                                                                                                                                                                         |
|--------------------|-----------------------------------------------------------------------------------------------------------------------------------------------------------------------------------------------------------------------------------------------------------------------------------------------------------------------------------------------------------------------------------------------------------------------------------------------------------------------------------------------------------------------------------------------------------------------------------------------------------------------------------------|
| <b>Syntax</b>      | <b>authentication-type</b> { <b>password</b>   <b>message-digest</b> }<br><b>no authentication</b>                                                                                                                                                                                                                                                                                                                                                                                                                                                                                                                                      |
| <b>Context</b>     | config>router>isis<br>config>router>isis>level <i>level-number</i>                                                                                                                                                                                                                                                                                                                                                                                                                                                                                                                                                                      |
| <b>Description</b> | <p>This command enables either simple password or message digest authentication or must go in either the global IS-IS or IS-IS level context.</p> <p>Both the authentication key and the authentication type on a segment must match. The <b>authentication-key</b> statement must also be included.</p> <p>Configure the authentication type on the global level in the <b>config&gt;router&gt;isis</b> context.</p> <p>Configure or override the global setting by configuring the authentication type in the <b>config&gt;router&gt;isis&gt;level</b> context.</p> <p>The <b>no</b> form of the command disables authentication.</p> |
| <b>Default</b>     | <b>no authentication-type</b> — No authentication type is configured and authentication is disabled.                                                                                                                                                                                                                                                                                                                                                                                                                                                                                                                                    |
| <b>Parameters</b>  | <b>password</b> — Specifies that simple password (plain text) authentication is required.<br><b>message-digest</b> — Specifies that MD5 authentication in accordance with RFC2104 is required.                                                                                                                                                                                                                                                                                                                                                                                                                                          |

### bfd-enable

|                    |                                                                                                                                                                                                                                                                                                                                                                                                                                                                                                                                                |
|--------------------|------------------------------------------------------------------------------------------------------------------------------------------------------------------------------------------------------------------------------------------------------------------------------------------------------------------------------------------------------------------------------------------------------------------------------------------------------------------------------------------------------------------------------------------------|
| <b>Syntax</b>      | <b>[no] bfd-enable</b> { <b>ipv4</b>   <b>ipv6</b> }                                                                                                                                                                                                                                                                                                                                                                                                                                                                                           |
| <b>Context</b>     | config>router>isis>interface                                                                                                                                                                                                                                                                                                                                                                                                                                                                                                                   |
| <b>Description</b> | <p>This command enables the use of bi-directional forwarding (BFD) to control IPv4 adjacencies. By enabling BFD on an IPv4 or IPv6 protocol interface, the state of the protocol interface is tied to the state of the BFD session between the local node and the remote node. The parameters used for the BFD are set by the BFD command under the IP interface. This command must be given separately to enable/disable BFD for both IPv4 and IPv6.</p> <p>The <b>no</b> form of this command removes BFD from the associated adjacency.</p> |
| <b>Default</b>     | no bfd-enable ipv4                                                                                                                                                                                                                                                                                                                                                                                                                                                                                                                             |

## default-route-tag

|                    |                                                                    |
|--------------------|--------------------------------------------------------------------|
| <b>Syntax</b>      | <b>default-route-tag</b> <i>tag</i><br><b>no default-route-tag</b> |
| <b>Context</b>     | config>router>isis                                                 |
| <b>Description</b> | This command configures the route tag for default route.           |
| <b>Parameters</b>  | <i>tag</i> — <i>tag</i> — Assigns a default tag                    |
| <b>Values</b>      | Accepts decimal or hex formats:<br>ISIS: [0x0..0xFFFFFFFF]H        |
| <b>Values</b>      | 1 — 4294967295                                                     |

## csnp-authentication

|                    |                                                                                                                                                                                                  |
|--------------------|--------------------------------------------------------------------------------------------------------------------------------------------------------------------------------------------------|
| <b>Syntax</b>      | <b>[no] csnp-authentication</b>                                                                                                                                                                  |
| <b>Context</b>     | config>router>isis<br>config>router>isis>level <i>level-number</i>                                                                                                                               |
| <b>Description</b> | This command enables authentication of individual ISIS packets of complete sequence number PDUs (CSNP) type.<br><br>The <b>no</b> form of the command suppresses authentication of CSNP packets. |

## csnp-interval

|                    |                                                                                                                                                                                                                                      |
|--------------------|--------------------------------------------------------------------------------------------------------------------------------------------------------------------------------------------------------------------------------------|
| <b>Syntax</b>      | <b>csnp-interval</b> <i>seconds</i><br><b>no csnp-interval</b>                                                                                                                                                                       |
| <b>Context</b>     | config>router>isis>interface <i>ip-int-name</i>                                                                                                                                                                                      |
| <b>Description</b> | This command configures the time interval, in seconds, to send complete sequence number (CSN) PDUs from the interface. IS-IS must send CSN PDUs periodically.<br><br>The <b>no</b> form of the command reverts to the default value. |
| <b>Default</b>     | <b>csnp-interval 10</b> — CSN PDUs are sent every 10 seconds for LAN interfaces.<br><b>csnp-interval 5</b> — CSN PDUs are sent every 5 seconds for point-to-point interfaces.                                                        |
| <b>Parameters</b>  | <i>seconds</i> — The time interval, in seconds between successive CSN PDUs sent from this interface expressed as a decimal integer.                                                                                                  |
| <b>Values</b>      | 1 — 65535                                                                                                                                                                                                                            |

### default-metric

|                    |                                                                                                                                                                        |
|--------------------|------------------------------------------------------------------------------------------------------------------------------------------------------------------------|
| <b>Syntax</b>      | <b>default-metric</b> <i>ipv4 metric</i><br><b>no default-metric</b>                                                                                                   |
| <b>Context</b>     | config>router>isis>level                                                                                                                                               |
| <b>Description</b> | This command specifies the configurable default metric used for all IS-IS interfaces on this level. This value is not used if a metric is configured for an interface. |
| <b>Default</b>     | 10<br><i>ipv4 metric</i> — Specifies the default metric for IPv4 unicast.                                                                                              |
| <b>Values</b>      | 1 — 16777215                                                                                                                                                           |

### disable-ldp-sync

|                    |                                                                                                                                                                                                                                                                                                                                                                                                                                                                                                                                                                                                                                                                                                                                                                                                                                              |
|--------------------|----------------------------------------------------------------------------------------------------------------------------------------------------------------------------------------------------------------------------------------------------------------------------------------------------------------------------------------------------------------------------------------------------------------------------------------------------------------------------------------------------------------------------------------------------------------------------------------------------------------------------------------------------------------------------------------------------------------------------------------------------------------------------------------------------------------------------------------------|
| <b>Syntax</b>      | <b>[no] disable-ldp-sync</b>                                                                                                                                                                                                                                                                                                                                                                                                                                                                                                                                                                                                                                                                                                                                                                                                                 |
| <b>Context</b>     | config>router>isis                                                                                                                                                                                                                                                                                                                                                                                                                                                                                                                                                                                                                                                                                                                                                                                                                           |
| <b>Description</b> | <p>This command disables the IGP-LDP synchronization feature on all interfaces participating in the OSPF or IS-IS routing protocol. When this command is executed, IGP immediately advertises the actual value of the link cost for all interfaces which have the IGP-LDP synchronization enabled if the currently advertized cost is different. It will then disable IGP-LDP synchronornization for all interfaces. This command does not delete the interface configuration. The <b>no</b> form of this command has to be entered to re-enable IGP-LDP synchronization for this routing protocol.</p> <p>The <b>no</b> form of this command restores the default settings and re-enables IGP-LDP synchronization on all interfaces participating in the OSPF or IS-IS routing protocol and for which the ldp-sync-timer is configured.</p> |
| <b>Default</b>     | no disable-ldp-sync                                                                                                                                                                                                                                                                                                                                                                                                                                                                                                                                                                                                                                                                                                                                                                                                                          |

### export

|                    |                                                                                                                                                                                                                                                                                                                                                                                                                                                                                                                                                     |
|--------------------|-----------------------------------------------------------------------------------------------------------------------------------------------------------------------------------------------------------------------------------------------------------------------------------------------------------------------------------------------------------------------------------------------------------------------------------------------------------------------------------------------------------------------------------------------------|
| <b>Syntax</b>      | <b>[no] export</b> <i>policy-name</i> [ <i>policy-name</i> ...up to 5 max]                                                                                                                                                                                                                                                                                                                                                                                                                                                                          |
| <b>Context</b>     | config>router>isis                                                                                                                                                                                                                                                                                                                                                                                                                                                                                                                                  |
| <b>Description</b> | <p>This command configures export routing policies that determine the routes exported from the routing table to IS-IS.</p> <p>If no export policy is defined, non IS-IS routes are not exported from the routing table manager to IS-IS.</p> <p>If multiple policy names are specified, the policies are evaluated in the order they are specified. The first policy that matches is applied. If multiple export commands are issued, the last command entered overrides the previous command. A maximum of five policy names can be specified.</p> |



If an **aggregate** command is also configured in the **config>router** context, then the aggregation is applied before the export policy is applied.

Routing policies are created in the **config>router>policy-options** context.

The **no** form of the command removes the specified *policy-name* or all policies from the configuration if no *policy-name* is specified.

**Default** **no export** — No export policy name is specified.

**Parameters** *policy-name* — The export policy name. Up to five *policy-name* arguments can be specified.

## export-limit

**Syntax** **export-limit** *number* [**log** *percentage*]  
**no export-limit**

**Context** config>router>isis

**Description** This command configures the maximum number of routes (prefixes) that can be exported into IS-IS from the route table.

The **no** form of the command removes the parameters from the configuration.

**Default** no export-limit, the export limit for routes or prefixes is disabled..

**Parameters** *number* — Specifies the maximum number of routes (prefixes) that can be exported into RIP from the route table.

**Values** 1 — 4294967295

**log percentage** — Specifies the percentage of the export-limit, at which a warning log message and SNMP notification would be sent.

**Values** 1 — 100

## external-preference

**Syntax** **external-preference** *preference*  
**no external-preference**

**Context** config>router>isis>level *level-number*

**Description** This command configures the external route preference for the IS-IS level.

The **external-preference** command configures the preference level of either IS-IS level 1 or IS-IS level 2 external routes. By default, the preferences are as listed in the table below.

A route can be learned by the router by different protocols, in which case, the costs are not comparable. When this occurs, the preference decides the route to use.

Different protocols should not be configured with the same preference, if this occurs the tiebreaker is dependent on the default preference table. If multiple routes are learned with an identical preference using the

## Generic Commands

same protocol, the lowest cost route is used. If multiple routes are learned with an identical preference using the same protocol and the costs (metrics) are equal, then the decision of the route to use is determined by the configuration of the **ecmp** in the **config>router** context.

**Default** Default preferences are listed in the following table:

| Route Type             | Preference | Configurable |
|------------------------|------------|--------------|
| Direct attached        | 0          | No           |
| Static-route           | 5          | Yes          |
| OSPF internal routes   | 10         | No           |
| IS-IS Level 1 internal | 15         | Yes*         |
| IS-IS Level 2 internal | 18         | Yes*         |
| OSPF external          | 150        | Yes          |
| IS-IS Level 1 external | 160        | Yes          |
| IS-IS Level 2 external | 165        | Yes          |
| BGP                    | 170        | Yes          |

\*. Internal preferences are changed using the **preference** command in the **config>router>isis>level *level-number*** context

**Parameters** *preference* — The preference for external routes at this level as expressed.

**Values** 1 — 255

## graceful-restart

**Syntax** [no] graceful-restart

**Context** config>router>isis

**Description** This command enables graceful-restart helper support for ISIS. The 7750 SR OS will act as a helper to neighbors who are graceful-restart-capable and are restarting.

When the control plane of a graceful-restart-capable router fails, the neighboring routers (graceful-restart helpers) temporarily preserve adjacency information so packets continue to be forwarded through the failed graceful-restart router using the last known routes. If the control plane of the graceful-restart router comes back up within the timer limits, then the routing protocols re-converge to minimize service interruption.

The **no** form of the command disables graceful restart and removes all graceful restart configurations in the ISIS instance.

**Default** disabled

## helper-disable

**Syntax** [no] helper-disable

**Context** config>router>isis>graceful-restart

**Description** This command disables the helper support for graceful restart.

When **graceful-restart** is enabled, the router can be a helper (meaning that the router is helping a neighbor to restart) or be a restarting router or both. The 7750 SR OS supports only helper mode. This facilitates the graceful restart of neighbors but will not act as a restarting router (meaning that the 7750 SR OS will not help the neighbors to restart).

The **no helper-disable** command enables helper support and is the default when graceful-restart is enabled.

**Default** disabled

## hello-authentication

**Syntax** [no] hello-authentication

**Context** config>router>isis  
config>router>isis>level *level-number*

**Description** This command enables authentication of individual ISIS packets of HELLO type.

The **no** form of the command suppresses authentication of HELLO packets.

## loopfree-alternate-exclude

**Syntax** [no] loopfree-alternate

**Context** configure>router>isis>level  
configure>router>isis>interface

**Description** This command instructs IGP to not include a specific interface or all interfaces participating in a specific IS-IS level or OSPF area in the SPF LFA computation. This provides a way of reducing the LFA SPF calculation where it is not needed.

When an interface is excluded from the LFA SPF in IS-IS, it is excluded in both level 1 and level 2. When it is excluded from the LFA SPF in OSPF, it is excluded in all areas. However, the above OSPF command can only be executed under the area in which the specified interface is primary and once enabled, the interface is excluded in that area and in all other areas where the interface is secondary. If the user attempts to apply it to an area where the interface is secondary, the command will fail.

The **no** form of this command re-instates the default value for this command.

**Default** no loopfree-alternate-exclude

### loopfree-alternate

|                    |                                                                                                                                                                                                                                                                                                                                                                                                                                                                                                                                      |
|--------------------|--------------------------------------------------------------------------------------------------------------------------------------------------------------------------------------------------------------------------------------------------------------------------------------------------------------------------------------------------------------------------------------------------------------------------------------------------------------------------------------------------------------------------------------|
| <b>Syntax</b>      | <b>[no] loopfree-alternate</b>                                                                                                                                                                                                                                                                                                                                                                                                                                                                                                       |
| <b>Context</b>     | config>router>isis                                                                                                                                                                                                                                                                                                                                                                                                                                                                                                                   |
| <b>Description</b> | <p>This command enables Loop-Free Alternate (LFA) computation by SPF under the IS-IS routing protocol level or under the OSPF routing protocol instance level.</p> <p>When this command is enabled, it instructs the IGP SPF to attempt to pre-compute both a primary next-hop and an LFA next-hop for every learned prefix. When found, the LFA next-hop is populated into the routing table along with the primary next-hop for the prefix.</p> <p>The <b>no</b> form of this command disables the LFA computation by IGP SPF.</p> |
| <b>Default</b>     | no loopfree-alternate                                                                                                                                                                                                                                                                                                                                                                                                                                                                                                                |

### hello-authentication-key

|                    |                                                                                                                                                                                                                                                                                                                                                                                                                                                                                                                                                                                                                                                                                                                                                                                                                                                                                                                                                                                                                                                                                                                                                                                                                                                              |
|--------------------|--------------------------------------------------------------------------------------------------------------------------------------------------------------------------------------------------------------------------------------------------------------------------------------------------------------------------------------------------------------------------------------------------------------------------------------------------------------------------------------------------------------------------------------------------------------------------------------------------------------------------------------------------------------------------------------------------------------------------------------------------------------------------------------------------------------------------------------------------------------------------------------------------------------------------------------------------------------------------------------------------------------------------------------------------------------------------------------------------------------------------------------------------------------------------------------------------------------------------------------------------------------|
| <b>Syntax</b>      | <b>hello-authentication-key</b> [ <i>authentication-key</i>   <i>hash-key</i> ] [ <b>hash</b>   <b>hash2</b> ]<br><b>no hello-authentication-key</b>                                                                                                                                                                                                                                                                                                                                                                                                                                                                                                                                                                                                                                                                                                                                                                                                                                                                                                                                                                                                                                                                                                         |
| <b>Context</b>     | config>router>isis>interface <i>ip-int-name</i><br>config>router>isis>if>level <i>level-number</i>                                                                                                                                                                                                                                                                                                                                                                                                                                                                                                                                                                                                                                                                                                                                                                                                                                                                                                                                                                                                                                                                                                                                                           |
| <b>Description</b> | <p>This command configures the authentication key (password) for hello PDUs. Neighboring routers use the password to verify the authenticity of hello PDUs sent from this interface. Both the hello authentication key and the hello authentication type on a segment must match. The <b>hello-authentication-type</b> must be specified.</p> <p>To configure the hello authentication key in the interface context use the <b>hello-authentication-key</b> in the <b>config&gt;router&gt;isis&gt;interface</b> context.</p> <p>To configure or override the hello authentication key for a specific level, configure the <b>hello-authentication-key</b> in the <b>config&gt;router&gt;isis&gt;interface&gt;level</b> context.</p> <p>If both IS-IS and hello-authentication are configured, hello messages are validated using hello authentication. If only IS-IS authentication is configured, it will be used to authenticate all IS-IS (including hello) protocol PDUs.</p> <p>When the hello authentication key is configured in the <b>config&gt;router&gt;isis&gt;interface</b> context, it applies to all levels configured for the interface.</p> <p>The <b>no</b> form of the command removes the authentication-key from the configuration.</p> |
| <b>Default</b>     | <b>no hello-authentication-key</b> — No hello authentication key is configured.                                                                                                                                                                                                                                                                                                                                                                                                                                                                                                                                                                                                                                                                                                                                                                                                                                                                                                                                                                                                                                                                                                                                                                              |
| <b>Parameters</b>  | <p><i>authentication-key</i> — The hello authentication key (password). The key can be any combination of ASCII characters up to 254 characters in length (un-encrypted). If spaces are used in the string, enclose the entire string in quotation marks (“ ”).</p> <p><i>hash-key</i> — The hash key. The key can be any combination of ASCII characters up to 342 characters in length (encrypted). If spaces are used in the string, enclose the entire string in quotation marks (“ ”).</p>                                                                                                                                                                                                                                                                                                                                                                                                                                                                                                                                                                                                                                                                                                                                                              |

This is useful when a user must configure the parameter, but, for security purposes, the actual unencrypted key value is not provided.

**hash** — Specifies the key is entered in an encrypted form. If the **hash** parameter is not used, the key is assumed to be in a non-encrypted, clear text form. For security, all keys are stored in encrypted form in the configuration file with the **hash** parameter specified.

**hash2** — Specifies the key is entered in a more complex encrypted form. If the **hash2** parameter is not used, the less encrypted **hash** form is assumed.

## hello-authentication-type

|                    |                                                                                                                                                                                                                                                                                                                                                                                                                                                                                                                                                                                                                                                                                                                             |
|--------------------|-----------------------------------------------------------------------------------------------------------------------------------------------------------------------------------------------------------------------------------------------------------------------------------------------------------------------------------------------------------------------------------------------------------------------------------------------------------------------------------------------------------------------------------------------------------------------------------------------------------------------------------------------------------------------------------------------------------------------------|
| <b>Syntax</b>      | <b>hello-authentication-type</b> { <b>password</b>   <b>message-digest</b> }<br><b>no hello-authentication-type</b>                                                                                                                                                                                                                                                                                                                                                                                                                                                                                                                                                                                                         |
| <b>Context</b>     | config>router>isis>interface <i>ip-int-name</i><br>config>router>isis>if>level <i>level-number</i>                                                                                                                                                                                                                                                                                                                                                                                                                                                                                                                                                                                                                          |
| <b>Description</b> | <p>This command enables hello authentication at either the interface or level context. Both the hello authentication key and the hello authentication type on a segment must match. The hello <b>authentication-key</b> statement must also be included.</p> <p>To configure the hello authentication type at the interface context, use <b>hello-authentication-type</b> in the <b>config&gt;router&gt;isis&gt;interface</b> context.</p> <p>To configure or override the hello authentication setting for a given level, configure the <b>hello-authentication-type</b> in the <b>config&gt;router&gt;isis&gt;interface&gt;level</b> context.</p> <p>The <b>no</b> form of the command disables hello authentication.</p> |
| <b>Default</b>     | <b>no hello-authentication-type</b> — Hello authentication is disabled.                                                                                                                                                                                                                                                                                                                                                                                                                                                                                                                                                                                                                                                     |
| <b>Parameters</b>  | <p><b>password</b> — Specifies simple password (plain text) authentication is required.</p> <p><b>message-digest</b> — Specifies MD5 authentication in accordance with RFC2104 (HMAC: Keyed-Hashing for Message Authentication) is required.</p>                                                                                                                                                                                                                                                                                                                                                                                                                                                                            |

## hello-interval

|                    |                                                                                                                                                                                                 |
|--------------------|-------------------------------------------------------------------------------------------------------------------------------------------------------------------------------------------------|
| <b>Syntax</b>      | <b>hello-interval</b> <i>seconds</i><br><b>no hello-interval</b>                                                                                                                                |
| <b>Context</b>     | config>router>isis>if>level <i>level-number</i>                                                                                                                                                 |
| <b>Description</b> | <p>This command configures the interval in seconds between hello messages issued on this interface at this level.</p> <p>The <b>no</b> form of the command to reverts to the default value.</p> |
| <b>Default</b>     | <b>3</b> — Hello interval default for the designated intersystem.                                                                                                                               |

## Generic Commands

**9** — Hello interval default for non-designated intersystems.

**Parameters** *seconds* — The hello interval in seconds expressed as a decimal integer.

**Values** 1 — 20000

## hello-multiplier

**Syntax** **hello-multiplier** *multiplier*  
**no hello-multiplier**

**Context** config>router>isis>if>level *level-number*

**Description** This command configures the number of missing hello PDUs from a neighbor after the router declares the adjacency down.

The **no** form of the command reverts to the default value.

**Default** **3** — The router can miss up to 3 hello messages before declaring the adjacency down.

**Parameters** *multiplier* — The multiplier for the hello interval expressed as a decimal integer.

**Values** 2 — 100

## ipv6-unicast-metric

**Syntax** **ipv6-unicast-metric** *metric*  
**no ipv6-unicast-metric**

**Context** config>router>isis>if>level

**Description** This command configures IS-IS interface metric for IPv6 unicast.

The **no** form of this command removes the metric from the configuration.

**Parameters** *metric* — Specifies the IS-IS interface metric for IPv6 unicast.

**Values** 1 — 16777215

## interface

**Syntax** [**no**] **interface** *ip-int-name*

**Context** config>router>isis

**Description** This command creates the context to configure an IS-IS interface.

When an area is defined, the interfaces belong to that area. Interfaces cannot belong to separate areas.

When the interface is a POS channel, the OSINCP is enabled when the interface is created and removed when the interface is deleted.

The **no** form of the command removes IS-IS from the interface.

The **shutdown** command in the **config>router>isis>interface** context administratively disables IS-IS on the interface without affecting the IS-IS configuration.

**Default** **no interface** — No IS-IS interfaces are defined.

**Parameters** *ip-int-name* — Identify the IP interface name created in the **config>router>interface** context. The IP interface name must already exist.

## interface-type

**Syntax** **interface-type** {**broadcast** | **point-to-point**}  
**no interface-type**

**Context** config>router>isis>interface *ip-int-name*

**Description** This command configures the IS-IS interface type as either broadcast or point-to-point.

Use this command to set the interface type of an Ethernet link to point-to-point to avoid having to carry the designated IS-IS overhead if the link is used as a point-to-point.

If the interface type is not known at the time the interface is added to IS-IS and subsequently the IP interface is bound (or moved) to a different interface type, then this command must be entered manually.

The **no** form of the command reverts to the default value.

**Special Cases** **SONET** — Interfaces on SONET channels default to the point-to-point type.

**Ethernet or Unknown** — Physical interfaces that are Ethernet or unknown default to the broadcast type.

**Default** **point-to-point** — For IP interfaces on SONET channels.

**broadcast** — For IP interfaces on Ethernet or unknown type physical interfaces.

**Parameters** **broadcast** — Configures the interface to maintain this link as a broadcast network.

**point-to-point** — Configures the interface to maintain this link as a point-to-point link.

## ipv4-routing

**Syntax** [**no**] **ipv4-routing**

**Context** config>router>isis

**Description** This command specifies whether this IS-IS instance supports IPv4.

The **no** form of the command disables IPv4 on the IS-IS instance.

**Default** ipv4-routing

## Generic Commands

### ipv6-routing

|                    |                                                                                                                                                                                                                                                       |
|--------------------|-------------------------------------------------------------------------------------------------------------------------------------------------------------------------------------------------------------------------------------------------------|
| <b>Syntax</b>      | <b>[no] ipv6-routing {native   mt}</b>                                                                                                                                                                                                                |
| <b>Context</b>     | config>router>isis                                                                                                                                                                                                                                    |
| <b>Description</b> | This command enables IPv6 routing.<br>The <b>no</b> form of the command disables support for IS-IS IPv6 TLVs for IPv6 routing.                                                                                                                        |
| <b>Default</b>     | disabled                                                                                                                                                                                                                                              |
| <b>Parameters</b>  | <b>native</b> — Enables IS-IS IPv6 TLVs for IPv6 routing and enables support for native IPv6 TLVs.<br><b>mt</b> — Enables IS-IS multi-topology TLVs for IPv6 routing. When this parameter is specified, the support for native IPv6 TLVs is disabled. |

### ldp-over-rsvp

|                    |                                                                                                                                |
|--------------------|--------------------------------------------------------------------------------------------------------------------------------|
| <b>Syntax</b>      | <b>[no] ldp-over-rsvp</b>                                                                                                      |
| <b>Context</b>     | config>router>isis                                                                                                             |
| <b>Description</b> | This command allows LDP over RSVP processing in IS-IS.<br>The <b>no</b> form of the command disables LDP over RSVP processing. |
| <b>Default</b>     | no ldp-over-rsvp                                                                                                               |

### iid-tlv-enable

|                    |                                                                                                                                                                                                                                                                                                                             |
|--------------------|-----------------------------------------------------------------------------------------------------------------------------------------------------------------------------------------------------------------------------------------------------------------------------------------------------------------------------|
| <b>Syntax</b>      | <b>[no] iid-tlv-enable</b>                                                                                                                                                                                                                                                                                                  |
| <b>Context</b>     | config>router>isis                                                                                                                                                                                                                                                                                                          |
| <b>Description</b> | This command specifies whether Instance Identifier (IID) TLV has been enabled or disabled for this ISIS instance.<br>When enabled, each I-IS instance marks its packets with the IID TLV containing its unique 16-bit IID for the routing domain. You should shut/no shut the isis instance to make the change operational. |
| <b>Default</b>     | no iid-tlv-enable                                                                                                                                                                                                                                                                                                           |



## level

**Syntax** `level level-number`

**Context** `config>router>isis`  
`config>router>isis>interface ip-int-name`

**Description** This command creates the context to configure IS-IS Level 1 or Level 2 area attributes.

A router can be configured as a Level 1, Level 2, or Level 1-2 system. A Level 1 adjacency can be established if there is at least one area address shared by this router and a neighbor. A Level 2 adjacency cannot be established over this interface.

Level 1/2 adjacency is created if the neighbor is also configured as Level 1/2 router and has at least one area address in common. A Level 2 adjacency is established if there are no common area IDs.

A Level 2 adjacency is established if another router is configured as Level 2 or a Level 1/2 router with interfaces configured as Level 1/2 or Level 2. Level 1 adjacencies will not be established over this interface.

To reset global and/or interface level parameters to the default, the following commands must be entered independently:

```
level> no hello-authentication-key
level> no hello-authentication-type
level> no hello-interval
level> no hello-multiplier
level> no metric
level> no passive
level> no priority
```

**Special Cases** **Global IS-IS Level** — The `config>router>isis` context configures default global parameters for both Level 1 and Level 2 interfaces.

**IS-IS Interface Level** — The `config>router>isis>interface` context configures IS-IS operational characteristics of the interface at Level 1 and/or Level 2. A logical interface can be configured on one Level 1 and one Level 2. In this case, each level can be configured independently and parameters must be removed independently.

By default an interface operates in both Level 1 and Level 2 modes.

**Default** level 1 or level 2

**Parameters** *level-number* — The IS-IS level number.

**Values** 1, 2

## level-capability

**Syntax** `level-capability {level-1 | level-2 | level-1/2}`  
`no level-capability`

**Context** `config>router>isis`  
`config>router>isis>interface ip-int-name`

**Description** This command configures the routing level for an instance of the IS-IS routing process. An IS-IS router and an IS-IS interface can operate at Level 1, Level 2 or both Level 1 *and* 2. Table 13 displays configuration combinations and the potential adjacencies that can be formed.

**Table 13: Potential Adjacency Capabilities**

| Global Level | Interface Level | Potential Adjacency    |
|--------------|-----------------|------------------------|
| L 1/2        | L 1/2           | Level 1 and/or Level 2 |
| L 1/2        | L 1             | Level 1 only           |
| L 1/2        | L 2             | Level 2 only           |
| L 2          | L 1/2           | Level 2 only           |
| L 2          | L 2             | Level 2 only           |
| L 2          | L 1             | none                   |
| L 1          | L 1/2           | Level 1 only           |
| L 1          | L 2             | none                   |
| L 1          | L 1             | Level 1 only           |

The **no** form of the command removes the level capability from the configuration.

**Special Cases** **IS-IS Router** — In the `config>router>isis` context, changing the **level-capability** performs a restart on the IS-IS protocol instance.

**IS-IS Interface** — In the `config>router>isis>interface` context, changing the **level-capability** performs a restart of IS-IS on the interface.

**Default** `level-1/2`

**Parameters** `level-1` — Specifies the router/interface can operate at Level 1 only.

`level-2` — Specifies the router/interface can operate at Level 2 only.

`level-1/2` — Specifies the router/interface can operate at both Level 1 and Level 2.

## lsp-pacing-interval

|                    |                                                                                                                                                                                                                                                                                                                                            |
|--------------------|--------------------------------------------------------------------------------------------------------------------------------------------------------------------------------------------------------------------------------------------------------------------------------------------------------------------------------------------|
| <b>Syntax</b>      | <b>lsp-pacing-interval</b> <i>milliseconds</i><br><b>no lsp-pacing-interval</b>                                                                                                                                                                                                                                                            |
| <b>Context</b>     | config>router>isis>interface <i>ip-int-name</i>                                                                                                                                                                                                                                                                                            |
| <b>Description</b> | This command configures the interval between LSP PDUs sent from this interface.<br>To avoid bombarding adjacent neighbors with excessive data, pace the Link State Protocol Data Units (LSP's). If a value of zero is configured, no LSP's are sent from the interface.<br>The <b>no</b> form of the command reverts to the default value. |
| <b>Default</b>     | <b>100</b> — LSPs are sent in 100 millisecond intervals.                                                                                                                                                                                                                                                                                   |
| <b>Parameters</b>  | <i>milliseconds</i> — The interval in milliseconds that IS-IS LSP's can be sent from the interface expressed as a decimal integer.                                                                                                                                                                                                         |
|                    | <b>Values</b> 0 — 65535                                                                                                                                                                                                                                                                                                                    |

## lsp-lifetime

|                    |                                                                                                                                                                                                                                                                                                                                                                                                                                                                                                                                                              |
|--------------------|--------------------------------------------------------------------------------------------------------------------------------------------------------------------------------------------------------------------------------------------------------------------------------------------------------------------------------------------------------------------------------------------------------------------------------------------------------------------------------------------------------------------------------------------------------------|
| <b>Syntax</b>      | <b>lsp-lifetime</b> <i>seconds</i><br><b>no lsp-lifetime</b>                                                                                                                                                                                                                                                                                                                                                                                                                                                                                                 |
| <b>Context</b>     | config>router>isis                                                                                                                                                                                                                                                                                                                                                                                                                                                                                                                                           |
| <b>Description</b> | This command sets the time, in seconds, the router wants the LSPs it originates to be considered valid by other routers in the domain.<br>Each LSP received is maintained in an LSP database until the <b>lsp-lifetime</b> expires unless the originating router refreshes the LSP. By default, each router refreshes its LSP's every 20 minutes (1200 seconds) so other routers will not age out the LSP.<br>The LSP refresh timer is derived from this formula: $\text{lsp-lifetime}/2$<br>The <b>no</b> form of the command reverts to the default value. |
| <b>Default</b>     | <b>1200</b> — LSPs originated by the router should be valid for 1200 seconds (20 minutes).                                                                                                                                                                                                                                                                                                                                                                                                                                                                   |
| <b>Parameters</b>  | <i>seconds</i> — The time, in seconds, that the router wants the LSPs it originates to be considered valid by other routers in the domain.                                                                                                                                                                                                                                                                                                                                                                                                                   |
|                    | <b>Values</b> 350 — 65535                                                                                                                                                                                                                                                                                                                                                                                                                                                                                                                                    |

## lsp-mtu-size

|                    |                                                                                                                                                                                                                                                                                                                                                                                                                                                                                                                                                                                                  |
|--------------------|--------------------------------------------------------------------------------------------------------------------------------------------------------------------------------------------------------------------------------------------------------------------------------------------------------------------------------------------------------------------------------------------------------------------------------------------------------------------------------------------------------------------------------------------------------------------------------------------------|
| <b>Syntax</b>      | <b>lsp-mtu-size</b> <i>size</i><br><b>no lsp-mtu-size</b>                                                                                                                                                                                                                                                                                                                                                                                                                                                                                                                                        |
| <b>Context</b>     | config>router>isis                                                                                                                                                                                                                                                                                                                                                                                                                                                                                                                                                                               |
| <b>Description</b> | This command configures the LSP MTU size. If the <i>size</i> value is changed from the default using CLI or SNMP, then ISIS must be restarted in order for the change to take effect. This can be done by performing a <b>shutdown</b> command and then a <b>no shutdown</b> command in the <b>config&gt;router&gt;isis</b> context. Note: Using the <b>exec</b> command to execute a configuration file to change the LSP MTU-size from its default value will automatically bounce IS-IS for the change to take effect.<br><br>The <b>no</b> form of the command reverts to the default value. |
| <b>Default</b>     | 1492                                                                                                                                                                                                                                                                                                                                                                                                                                                                                                                                                                                             |
| <b>Parameters</b>  | <i>size</i> — Specifies the LSP MTU size.<br><br><b>Values</b> 490 — 9190                                                                                                                                                                                                                                                                                                                                                                                                                                                                                                                        |

## lsp-wait

|                    |                                                                                                                                                                                                                                                                                                                                                                                                                                                                                           |
|--------------------|-------------------------------------------------------------------------------------------------------------------------------------------------------------------------------------------------------------------------------------------------------------------------------------------------------------------------------------------------------------------------------------------------------------------------------------------------------------------------------------------|
| <b>Syntax</b>      | <b>lsp-wait</b> <i>lsp-wait</i> [ <i>lsp-initial-wait</i> [ <i>lsp-second-wait</i> ]]                                                                                                                                                                                                                                                                                                                                                                                                     |
| <b>Context</b>     | config>router>isis                                                                                                                                                                                                                                                                                                                                                                                                                                                                        |
| <b>Description</b> | This command is used to customize the throttling of IS-IS LSP-generation. Timers that determine when to generate the first, second and subsequent LSPs can be controlled with this command. Subsequent LSPs are generated at increasing intervals of the second <b>lsp-wait</b> timer until a maximum value is reached.                                                                                                                                                                   |
| <b>Parameters</b>  | <i>lsp-max-wait</i> — Specifies the maximum interval in seconds between two consecutive occurrences of an LSP being generated.<br><br><b>Values</b> 1 — 120<br><b>Default</b> 5<br><br><i>lsp-initial-wait</i> — Specifies the initial LSP generation delay in seconds.<br><br><b>Values</b> 0 — 100<br><b>Default</b> 0<br><br><i>lsp-second-wait</i> — Specifies the hold time in seconds between the first and second LSP generation.<br><br><b>Values</b> 1 — 100<br><b>Default</b> 1 |

## mcast-import-ipv6

**Syntax** [no] mcast-import-ipv6

**Context** configure>router>isis

**Description** This command administratively enables/disables submission of routes into the IPv6 multicast RTM by IS-IS.

## multi-topology

**Syntax** [no] multi-topology

**Context** config>router>isis

**Description** This command enables IS-IS multi-topology support.

**Default** disabled

## ipv6-unicast

**Syntax** [no] ipv6-unicast

**Context** config>router>isis>multi-topology

**Description** This command enables multi-topology TLVs.  
The no form of the command disables multi-topology TLVs.

## multicast-import

**Syntax** [no] multicast-import

**Context** config>router>isis

**Description** This command enables the submission of routes into the multicast Route Table Manager (RTM) by IS-IS.  
The **no** form of the command disables the submission of routes into the multicast RTM.

**Default** no multicast-import

### mesh-group

|                    |                                                                                                                                                                                                                                                                                                                                                                                                                                                                                                                                                                                                                                                                                                                                                                                                                                                                                            |
|--------------------|--------------------------------------------------------------------------------------------------------------------------------------------------------------------------------------------------------------------------------------------------------------------------------------------------------------------------------------------------------------------------------------------------------------------------------------------------------------------------------------------------------------------------------------------------------------------------------------------------------------------------------------------------------------------------------------------------------------------------------------------------------------------------------------------------------------------------------------------------------------------------------------------|
| <b>Syntax</b>      | <b>mesh-group</b> { <b>value</b> / <b>blocked</b> }<br><b>no mesh-group</b>                                                                                                                                                                                                                                                                                                                                                                                                                                                                                                                                                                                                                                                                                                                                                                                                                |
| <b>Context</b>     | config>router>isis>interface <i>ip-int-name</i>                                                                                                                                                                                                                                                                                                                                                                                                                                                                                                                                                                                                                                                                                                                                                                                                                                            |
| <b>Description</b> | <p>This command assigns an interface to a mesh group. Mesh groups limit the amount of flooding that occurs when a new or changed LSP is advertised throughout an area.</p> <p>All routers in a mesh group should be fully meshed. When LSPs need to be flooded, only a single copy is received rather than a copy per neighbor.</p> <p>To create a mesh group, configure the same mesh group value for each interface that is part of the mesh group. All routers must have the same mesh group value configured for all interfaces that are part of the mesh group.</p> <p>To prevent an interface from flooding LSPs, the optional <b>blocked</b> parameter can be specified. Configure mesh groups carefully. It is easy to create isolated islands that do not receive updates as (other) links fail. The <b>no</b> form of the command removes the interface from the mesh group.</p> |
| <b>Default</b>     | <b>no mesh-group</b> — The interface does not belong to a mesh group.                                                                                                                                                                                                                                                                                                                                                                                                                                                                                                                                                                                                                                                                                                                                                                                                                      |
| <b>Parameters</b>  | <p><b>value</b> — The unique decimal integer value distinguishes this mesh group from other mesh groups on this or any other router that is part of this mesh group.</p> <p><b>Values</b> 1 — 2000000000</p> <p><b>blocked</b> — Prevents an interface from flooding LSPs.</p>                                                                                                                                                                                                                                                                                                                                                                                                                                                                                                                                                                                                             |

### ipv6-unicast-disable

|                    |                                                                                                                                                                                                                                                                                                                                                                               |
|--------------------|-------------------------------------------------------------------------------------------------------------------------------------------------------------------------------------------------------------------------------------------------------------------------------------------------------------------------------------------------------------------------------|
| <b>Syntax</b>      | <b>[no] ipv6-unicast-disable</b>                                                                                                                                                                                                                                                                                                                                              |
| <b>Context</b>     | config>router>isis>if                                                                                                                                                                                                                                                                                                                                                         |
| <b>Description</b> | <p>This command disables IS-IS IPv6 unicast routing for the interface.</p> <p>By default IPv6 unicast on all interfaces is enabled. However, IPv6 unicast routing on IS-IS is in effect when the <b>config&gt;router&gt;isis&gt;ipv6-routing mt</b> command is configured.</p> <p>The <b>no</b> form of the command enables IS-IS IPv6 unicast routing for the interface.</p> |

### metric

|                    |                                                                         |
|--------------------|-------------------------------------------------------------------------|
| <b>Syntax</b>      | <b>metric</b> <i>metric</i><br><b>no metric</b>                         |
| <b>Context</b>     | config>router>isis>if>level <i>level-number</i>                         |
| <b>Description</b> | This command configures the metric used for the level on the interface. |

In order to calculate the lowest cost to reach a given destination, each configured level on each interface must have a cost. The costs for each level on an interface may be different.

If the metric is not configured, the default of 10 is used unless reference bandwidth is configured.

The **no** form of the command reverts to the default value.

**Default** 10 — A metric of 10 for the level on the interface is used.

**Parameters** *metric* — The metric assigned for this level on this interface.

**Values** 1 — 16777215

## advertise-passive-only

**Syntax** [no] advertise-passive-only

**Context** config>router>isis

**Description** This command enables and disables IS-IS to advertise only prefixes that belong to passive interfaces.

## area-id

**Syntax** [no] area-id *area-address*

**Context** config>router>isis

**Description** This command was previously named the **net** *network-entity-title* command. The **area-id** command allows you to configure the area ID portion of NSAP addresses which identifies a point of connection to the network, such as a router interface, and is called a Network Service Access Point (NSAP). Addresses in the IS-IS protocol are based on the ISO NSAP addresses and Network Entity Titles (NETs), not IP addresses.

A maximum of 3 area addresses can be configured.

NSAP addresses are divided into three parts. Only the area ID portion is configurable.

- Area ID — A variable length field between 1 and 13 bytes long. This includes the Authority and Format Identifier (AFI) as the most significant byte and the area ID.
- System ID — A six-byte system identification. This value is not configurable. The system ID is derived from the system or router ID.
- Selector ID — A one-byte selector identification that must contain zeros when configuring a NET. This value is not configurable. The selector ID is always 00.

The NET is constructed like an NSAP but the selector byte contains a 00 value. NET addresses are exchanged in hello and LSP PDUs. All net addresses configured on the node are advertised to its neighbors.

For Level 1 interfaces, neighbors can have different area IDs, but, they must have at least one area ID (AFI + area) in common. Sharing a common area ID, they become neighbors and area merging between the potentially different areas can occur.

For Level 2 (only) interfaces, neighbors can have different area IDs. However, if they have no area IDs in common, they become only Level 2 neighbors and Level 2 LSPs are exchanged.

## Generic Commands

For Level 1 and Level 2 interfaces, neighbors can have different area IDs. If they have at least one area ID (AFI + area) in common, they become neighbors. In addition to exchanging Level 2 LSPs, area merging between potentially different areas can occur.

If multiple **area-id** commands are entered, the system ID of all subsequent entries must match the first area address.

The **no** form of the command removes the area address.

**Default** **none** — No area address is assigned.

**Parameters** *area-address* — The 1 — 13-byte address. Of the total 20 bytes comprising the NET, only the first 13 bytes can be manually configured. As few as one byte can be entered or, at most, 13 bytes. If less than 13 bytes are entered, the rest is padded with zeros.

## overload

**Syntax** **overload [timeout seconds]**  
**no overload**

**Context** config>router>isis

**Description** This command administratively sets the IS-IS router to operate in the overload state for a specific time period, in seconds, or indefinitely.

During normal operation, the router may be forced to enter an overload state due to a lack of resources. When in the overload state, the router is only used if the destination is reachable by the router and will not be used for other transit traffic.

If a time period is specified, the overload state persists for the configured length of time. If no time is specified, the overload state operation is maintained indefinitely.

The **overload** command can be useful in circumstances where the router is overloaded or used prior to executing a **shutdown** command to divert traffic around the router.

The **no** form of the command causes the router to exit the overload state.

**Default** **no overload**

**Parameters** *seconds* — The time, in seconds, that this router must operate in overload state.

**Default** infinity (overload state maintained indefinitely)

**Values** 60 — 1800



## overload-on-boot

**Syntax** **overload-on-boot** [*timeoutseconds*]  
**no overload-on-boot**

**Context** config>router>isis

**Description** When the router is in an overload state, the router is used only if there is no other router to reach the destination. This command configures the IGP upon bootup in the overload state until one of the following events occur:

1. The timeout timer expires.
2. A manual override of the current overload state is entered with the **config>router>isis>no overload** command.

The **no overload** command does not affect the **overload-on-boot** function.

If no timeout is specified, IS-IS will go into overload indefinitely after a reboot. After the reboot, the IS-IS status will display a permanent overload state:

L1 LSDB Overload : Manual on boot (Indefinitely in overload)

L2 LSDB Overload : Manual on boot (Indefinitely in overload)

This state can be cleared with the **config>router>isis>no overload** command.

When specifying a timeout value, IS-IS will go into overload for the configured timeout after a reboot. After the reboot, the IS-IS status will display the remaining time the system stays in overload:

L1 LSDB Overload : Manual on boot (Overload Time Left : 17)

L2 LSDB Overload : Manual on boot (Overload Time Left : 17)

The overload state can be cleared before the timeout expires with the **config>router>isis>no overload** command.

The **no** form of the command removes the overload-on-boot functionality from the configuration.

**Default** no overload-on-boot

Use **show router ospf status** and/or **show router isis status** commands to display the administrative and operational state as well as all timers.

**Parameters** **timeout seconds** — Configure the timeout timer for overload-on-boot in seconds.

**Values** 60 — 1800

## Generic Commands

### passive

**Syntax** [no] **passive**

**Context** config>router>isis>interface *ip-int-name*  
config>router>isis>if>level *level-number*

**Description** This command adds the passive attribute which causes the interface to be advertised as an IS-IS interface without running the IS-IS protocol. Normally, only interface addresses that are configured for IS-IS are advertised as IS-IS interfaces at the level that they are configured.

When the passive mode is enabled, the interface or the interface at the level ignores ingress IS-IS protocol PDUs and will not transmit IS-IS protocol PDUs.

The **no** form of the command removes the passive attribute.

**Special Cases** **Service Interfaces** — Service interfaces (defined using the service-prefix command in **config>router**) are passive by default.

**All other Interfaces** — All other interfaces are not passive by default.

**Default** **passive** — Service interfaces are passive.  
**no passive** — All other interfaces are not passive.

### preference

**Syntax** **preference** *preference*  
**no preference**

**Context** config>router>isis>level *level-number*

**Description** This command configures the preference level of either IS-IS Level 1 or IS-IS Level 2 internal routes. By default, the preferences are listed in the table below.

A route can be learned by the router by different protocols, in which case, the costs are not comparable. When this occurs, the preference is used to decide to which route will be used.

Different protocols should not be configured with the same preference, if this occurs the tiebreaker is per the default preference table as defined in the table below. If multiple routes are learned with an identical preference using the same protocol, the lowest cost route is used. If multiple routes are learned with an identical preference using the same protocol and the costs (metrics) are equal, then the decision what route to use is determined by the configuration of the **ecmp** in the config>router context.

**Default** Default preferences are listed in the following table:

| Route Type           | Preference | Configurable |
|----------------------|------------|--------------|
| Direct attached      | 0          | No           |
| Static-route         | 5          | Yes          |
| OSPF internal routes | 10         | No           |

| Route Type             | Preference | Configurable | (Continued) |
|------------------------|------------|--------------|-------------|
| IS-IS level 1 internal | 15         | Yes          |             |
| IS-IS level 2 internal | 18         | Yes          |             |
| OSPF external          | 150        | Yes          |             |
| IS-IS level 1 external | 160        | Yes*         |             |
| IS-IS level 2 external | 165        | Yes*         |             |
| BGP                    | 170        | Yes          |             |

\*. External preferences are changed using the **external-preference** command in the `config>router>isis>level level-number` context.

**Parameters** *preference* — The preference for external routes at this level expressed as a decimal integer.

**Values** 1 — 255

## priority

**Syntax** **priority** *number*  
**no priority**

**Context** `config>router>isis>if>level level-number`

**Description** This command configures the priority of the IS-IS router interface for designated router election on a multi-access network.

This priority is included in hello PDUs transmitted by the interface on a multi-access network. The router with the highest priority is the preferred designated router. The designated router is responsible for sending LSPs with regard to this network and the routers that are attached to it.

The **no** form of the command reverts to the default value.

**Default** 64

**Parameters** *number* — The priority for this interface at this level.

**Values** 0 — 127

## psnp-authentication

**Syntax** [**no**] **psnp-authentication**

**Context** `config>router>isis`  
`config>router>isis>level`

**Description** This command enables authentication of individual ISIS packets of partial sequence number PDU (PSNP) type.

## Generic Commands

The **no** form of the command suppresses authentication of PSNP packets.

### reference-bandwidth

**Syntax** **reference-bandwidth** *reference-bandwidth*  
**no reference-bandwidth**

**Context** config>router>isis

**Description** This command configures the reference bandwidth that provides the basis of bandwidth relative costing. In order to calculate the lowest cost to reach a specific destination, each configured level on each interface must have a cost. If the reference bandwidth is defined, then the cost is calculated using the following formula:

$$\text{cost} = \text{reference-bandwidth} \div \text{bandwidth}$$

If the reference bandwidth is configured as 10 Gigabits (10,000,000,000), a 100 M/bps interface has a default metric of 100. In order for metrics in excess of 63 to be configured, wide metrics must be deployed. (See wide-metrics-only in the **config>router>isis** context.)

If the reference bandwidth is not configured, then all interfaces have a default metric of 10.

The **no** form of the command reverts to the default value.

**Default** **no reference-bandwidth** — No reference bandwidth is defined. All interfaces have a metric of 10.

**Parameters** *reference-bandwidth* — The reference bandwidth in kilobits per second expressed as a decimal integer.

### rsvp-shortcut

**Syntax** [**no**] **rsvp-shortcut**

**Context** config>router>isis

**Description** This command enables the use of an RSVP-TE shortcut for resolving IGP routes by IS-IS or OSPF routing protocols.

This command instructs IS-IS or OSPF to include RSVP LSPs originating on this node and terminating on the router-id of a remote node as direct links with a metric equal to the operational metric provided by MPLS.

When **rsvp-shortcut** is enabled at the IGP instance level, all RSVP LSPs originating on this node are eligible by default as long as the destination address of the LSP, as configured in **config->router>mpls>lsp>to**, corresponds to a router-id of a remote node. RSVP LSPs with a destination address corresponding to an interface address of a remote node are automatically not considered by IS-IS or OSPF. The user can however exclude a specific RSVP LSP from being used as a shortcut for resolving IGP routes by entering the command **config>router>mpls>lsp>no igp-shortcut**.

Also, the SPF in OSPF or IS-IS will only use RSVP LSPs as IGP shortcuts or as endpoints for LDP-over-RSVP. These applications of RSVP LSPs are mutually exclusive at the IGP instance level. If the user enabled both options at the IGP instance level, then the shortcut application takes precedence when the LSP level configuration has both options enabled.

When an IPv4 packet is received on an ingress network interface, a subscriber IES interface, or a regular IES interface, the lookup of the packet in RTM will result in the resolution of the packet to an RSVP LSP if all the following conditions are satisfied:

- RSVP shortcut is enabled on the IGP routing protocol which has a route for the packet's destination address.
- SPF has pre-determined that the IGP path cost using the RSVP LSP shortcut is the best.

In this case, the packet is sent labeled with the label stack corresponding to the NHLFE of the RSVP LSP.

The failure of an RSVP LSP shortcut or of a local interface triggers a full SPF computation which may result in installing a new route over another RSVP LSP shortcut or a regular IP next-hop.

When ECMP is enabled and multiple equal-cost paths exist for the IGP route, the ingress IOM will spray the packets for this route based on hashing routine currently supported for IPv4 packets. Spraying will be performed across a regular IP next-hop and across an RSVP shortcut next-hop as long as the IP path does not go over the tail-end of the RSVP LSP.

The **no** form of this command disables the resolution of IGP routes using RSVP shortcuts.

**Default** no rsvp-shortcut

## advertise-tunnel-links

**Syntax** [no] advertise-tunnel-links

**Context** config>router>isis

**Description** This command enables the advertisement of RSVP LSP shortcuts into IGP similar to regular links so that other routers in the network can include them in their SPF computations. An LSP must exist in the reverse direction in order for the advertized link to pass the bi-directional link check and be usable by other routers in the network. However, this is not required for the node which originates the LSP.

The LSP is advertised as an unnumbered point-to-point link and the link LSP/LSA has no Traffic Engineering opaque sub-TLVs per RFC 3906.

The no form of this command disables the advertisement of RSVP LSP shortcuts into IGP.

**Default** no advertise-tunnel-links

### retransmit-interval

|                    |                                                                                                                                                                                |
|--------------------|--------------------------------------------------------------------------------------------------------------------------------------------------------------------------------|
| <b>Syntax</b>      | <b>retransmit-interval</b> <i>seconds</i><br><b>no retransmit-interval</b>                                                                                                     |
| <b>Context</b>     | config>router>isis>interface <i>ip-int-name</i>                                                                                                                                |
| <b>Description</b> | This command configures the minimum time between LSP PDU retransmissions on a point-to-point interface.<br><br>The <b>no</b> form of the command reverts to the default value. |
| <b>Default</b>     | <b>100</b>                                                                                                                                                                     |
| <b>Parameters</b>  | <i>seconds</i> — The interval in seconds that IS-IS LSPs can be sent on the interface.<br><b>Values</b> 1 — 65535                                                              |

### spf-wait

|                    |                                                                                                                                                                                                                                                                                                                                                                                                                                                                                                                                                                                                                                                                                                                                                                                                                                         |
|--------------------|-----------------------------------------------------------------------------------------------------------------------------------------------------------------------------------------------------------------------------------------------------------------------------------------------------------------------------------------------------------------------------------------------------------------------------------------------------------------------------------------------------------------------------------------------------------------------------------------------------------------------------------------------------------------------------------------------------------------------------------------------------------------------------------------------------------------------------------------|
| <b>Syntax</b>      | <b>[no] spf-wait</b> <i>spf-wait</i> [ <i>spf-initial-wait</i> [ <i>spf-second-wait</i> ]]                                                                                                                                                                                                                                                                                                                                                                                                                                                                                                                                                                                                                                                                                                                                              |
| <b>Context</b>     | config>router>isis                                                                                                                                                                                                                                                                                                                                                                                                                                                                                                                                                                                                                                                                                                                                                                                                                      |
| <b>Description</b> | This command defines the maximum interval between two consecutive SPF calculations in seconds. Timers that determine when to initiate the first, second and subsequent SPF calculations after a topology change occurs can be controlled with this command. Subsequent SPF runs (if required) will occur at exponentially increasing intervals of the <i>spf-second-wait</i> interval. For example, if the <i>spf-second-wait</i> interval is 1000, then the next SPF will run after 2000 milliseconds, and then next SPF will run after 4000 milliseconds, etc., until it reaches the <i>spf-wait</i> value. The SPF interval will stay at <i>spf-wait</i> value until there are no more SPF runs scheduled in that interval. After a full interval without any SPF runs, the SPF interval will drop back to <i>spf-initial-wait</i> . |
| <b>Default</b>     | no spf-wait                                                                                                                                                                                                                                                                                                                                                                                                                                                                                                                                                                                                                                                                                                                                                                                                                             |
| <b>Parameters</b>  | <i>spf-wait</i> — Specifies the maximum interval in seconds between two consecutive spf calculations.<br><b>Values</b> 1 — 120<br><b>Default</b> 10<br><i>spf-initial-wait</i> — Specifies the initial SPF calculation delay in milliseconds after a topology change.<br><b>Values</b> 10 — 100000<br><b>Default</b> 1000<br><i>spf-second-wait</i> — Specifies the hold time in milliseconds between the first and second SPF calculation.<br><b>Values</b> 1 — 100000<br><b>Default</b> 1000                                                                                                                                                                                                                                                                                                                                          |

## strict-adjacency-check

**Syntax** [no] **strict-adjacency-check**

**Context** config>router>isis

**Description** This command enables strict checking of address families (IPv4 and IPv6) for IS-IS adjacencies. When enabled, adjacencies will not come up unless both routers have exactly the same address families configured. If there is an existing adjacency with unmatched address families, it will be torn down. This command is used to prevent black-holing traffic when IPv4 and IPv6 topologies are different. When disabled (no strict-adjacency-check) a BFD session failure for either IPv4 or Ipv6 will cause the routes for the other address family to be removed as well.

When disabled (**no strict-adjacency-check**), both routers only need to have one common address family to establish the adjacency.

**Default** no strict-adjacency-check

## summary-address

**Syntax** **summary-address** {*ip-prefix/mask* | *ip-prefix* [*netmask*]} *level* [**tag** *tag*]  
**no summary-address** {*ip-prefix/mask* | *ip-prefix* [*netmask*]}

**Context** config>router>isis

**Description** This command creates summary-addresses.

**Default** none

**Parameters** *ip-prefix/mask* — Specifies information for the specified IP prefix and mask length.

|               |                     |                                     |
|---------------|---------------------|-------------------------------------|
| <b>Values</b> | ipv4-prefix:        | a.b.c.d (host bits must be 0)       |
|               | ipv4-prefix-length: | 0 — 32                              |
|               | ipv6-prefix:        | x:x:x:x:x:x:x (eight 16-bit pieces) |
|               |                     | x:x:x:x:x:d.d.d.d                   |
|               |                     | x: [0 — FFFF]H                      |
|               |                     | d: [0 — 255]D                       |
|               | ipv6-prefix-length: | [0 — 128]                           |

*netmask* — The subnet mask in dotted decimal notation.

**Values** 0.0.0.0 — 255.255.255.255 (network bits all 1 and host bits all 0)

*level* — Specifies IS-IS level area attributes.

**Values** level-1, level-2, level-1/2

**tag** *tag* — Assigns an OSPF, RIP or ISIS tag to routes matching the entry.

**Values** Accepts decimal or hex formats:  
 OSPF and ISIS: [0x0..0xFFFFFFFF]H  
 RIP: [0x0..0xFFFF]H

## Generic Commands

### suppress-default

**Syntax** [no] **suppress-default**

**Context** config>router>isis

**Description** This command enables or disables IS-IS to suppress the installation of default routes.

### traffic-engineering

**Syntax** [no] **traffic-engineering**

**Context** config>router>isis

**Description** This command configures traffic-engineering and determines if IGP shortcuts are required by BGP.

**Default** disabled

### unicast-import-disable

**Syntax** [no] **unicast-import-disable**

**Context** config>router>isis

**Description** This command allows one IGP to import its routes into RPF RTM while another IGP imports routes only into the unicast RTM. Import policies can redistribute routes from an IGP protocol into the RPF RTM (the multicast routing table). By default, the IGP routes will not be imported into RPF RTM as such an import policy must be explicitly configured.

**Default** disabled

### wide-metrics-only

**Syntax** [no] **wide-metrics-only**

**Context** config>router>isis>level *level-number*

**Description** This command enables the exclusive use of wide metrics in the LSPs for the level number.. Narrow metrics can have values between 1 and 63. IS-IS can generate two TLVs, one for the adjacency and one for the IP prefix. In order to support traffic engineering, wider metrics are required. When wide metrics are used, a second pair of TLVs are added, again, one for the adjacency and one for the IP prefix.

By default, both sets of TLVs are generated. When wide-metrics-only is configured, IS-IS only generates the pair of TLVs with wide metrics for that level.

The **no** form of the command reverts to the default value.



---

# IS-IS Command Reference

---

## Command Hierarchies

### Configuration Commands

- [Global Commands on page 521](#)
- [Interface Commands on page 522](#)
- [Show Commands on page 524](#)
- [Clear Commands on page 524](#)
- [Debug Commands on page 524](#)

```

config
 — router
 — [no] isis [instance-id]
 — [no] advertise-passive-only
 — [no] advertise-tunnel-links
 — all-l1isis ieee-address
 — no all-l1isis
 — all-l2isisieee-address
 — no all-l2isis
 — [no] area-id area-address
 — [no] authentication-check
 — authentication-key [authentication-key | hash-key] [hash | hash2]
 — no authentication-key
 — authentication-type {password | message-digest}
 — no authentication-type
 — [no] csnp-authentication
 — default-route-tag tag
 — no default-route-tag
 — [no] disable-ldp-sync
 — export policy-name [.. policy-name]
 — no export
 — export-limit number [log percentage]
 — no export-limit
 — [no] graceful-restart
 — [no] helper-disable
 — [no] hello-authentication
 — [no] ipv4-routing
 — [no] ipv6-routing {native | mt}
 — [no] ldp-over-rsvp
 — level {1 | 2}
 — authentication-key [authentication-key | hash-key] [hash | hash2]
 — no authentication-key
 — authentication-type {password | message-digest}
 — no authentication-type

```

- [no] **csnp-authentication**
- **default-metric** *ipv4 metric*
- **no default-metric**
- **external-preference** *external-preference*
- **no external-preference**
- [no] **hello-authentication**
- [no] **loopfree-alternate-exclude**
- **preference** *preference*
- **no preference**
- [no] **psnp-authentication**
- [no] **wide-metrics-only**
- **level-capability** {**level-1** | **level-2** | **level-1/2**}
- [no] **loopfree-alternate**
- **lsp-lifetime** *seconds*
- **no lsp-lifetime**
- **lsp-mtu-size** *size*
- **no lsp-mtu-size**
- [no] **lsp-wait** *lsp-wait* [*lsp-initial-wait* [*lsp-second-wait*]]
- [no] **mcast-import-ipv6**
- [no] **multi-topology**
  - [no] **ipv6-unicast**
- [no] **multicast-import**
- **overload** [**timeout** *seconds*]
- **no overload**
- **overload-on-boot** [**timeout** *seconds*]
- **no overload-on-boot**
- [no] **psnp-authentication**
- **reference-bandwidth** *reference-bandwidth*
- **no reference-bandwidth**
- [no] **rsvp-shortcut**
- [no] **shutdown**
- [no] **spf-wait** *spf-wait* [*spf-initial-wait* [*spf-second-wait*]]
- [no] **strict-adjacency-check**
- [no] **suppress-default**
- **summary-address** {*ip-prefix/mask* | *ip-prefix* [*netmask*]} **level** [**tag** *tag*]
- **no summary-address** {*ip-prefix/mask* | *ip-prefix* [*netmask*]}
- [no] **traffic-engineering**
- [no] **unicast-import-disable**
- [no] **interface** *ip-int-name*
  - [no] **bfd-enable** {**ipv4** | **ipv6**}
  - **csnp-interval** *seconds*
  - **no csnp-interval**
  - **hello-authentication-key** [*authentication-key* | *hash-key*][**hash** | **hash2**]
  - **no hello-authentication-key**
  - **hello-authentication-type** {**password** | **message-digest**}
  - **no hello-authentication-type**
  - **interface-type** {**broadcast** | **point-to-point**}
  - **no interface-type**
  - [no] **metric**
  - **level** {**1** | **2**}
    - **hello-authentication-key** [*authentication-key* | *hash-key*] [**hash** | **hash2**]
    - **no hello-authentication-key**
    - **hello-authentication-type** [**password** | **message-digest**]

- **no hello-authentication-type**
- **hello-interval** *seconds*
- **no hello-interval**
- **hello-multiplier** *multiplier*
- **no hello-multiplier**
- **ipv6-unicast-metric** *metric*
- **no ipv6-unicast-metric**
- **metric** *metric*
- **no metric**
- **[no] passive**
- **priority** *number*
- **no priority**
- **level-capability** {**level-1** | **level-2** | **level-1/2**}
- **lsp-pacing-interval** *milli-seconds*
- **no lsp-pacing-interval**
- **[no] loopfree-alternate-exclude**
- **[no] loopfree-alternate**
- **mesh-group** [*value* / **blocked**]
- **no mesh-group**
- **[no] passive**
- **retransmit-interval** *seconds*
- **no retransmit-interval**
- **[no] shutdown**
- **tag** *tag*
- **no tag**

## Show Commands

## Show Commands

```
show
 — router
 — isis
 — adjacency [ip-address | ip-int-name | nbr-system-id] [detail]
 — database [system-id | lsp-id] [detail] [level level]
 — hostname
 — interface [ip-int-name | ip-address] [detail]
 — lfa-coverage
 — neighbor
 — routes [ipv4-unicast | ipv6-unicast | mt mt-id-number | alternative | ip-prefix/prefix-length]
 — spf [detail] [lfa]
 — spf-log [detail]
 — statistics
 — status
 — summary-address [ip-address [/mask]]
 — topology [ipv4-unicast | ipv6-unicast | mt mt-id-number] [detail]
```

## Clear Commands

```
clear
 — router
 — isis [isis-instance]
 — adjacency [system-id]
 — database [system-id]
 — export
 — spf-log
 — statistics
```

## Debug Commands

```
debug
 — router
 — isis
 — [no] adjacency [ip-int-name | ip-address | nbr-system-id]
 — [no] cspf
 — [no] graceful-restart
 — interface [ip-int-name | ip-address]
 — no interface
 — leak [ip-address]
 — no leak
 — [no] lsdB [level-number] [system-id | lsp-id]
 — [no] misc
 — packet [packet-type] [ip-int-name | ip-address] [detail]
 — rtm [ip-address]
 — no rtm
```

— [no] **spf** [*level-number*] [*system-id*]



## Show Commands

### isis

**Syntax** `isis [isis-instance]`

**Context** `show>router`

**Description** This command displays information for a specified IS-IS instance.

**Parameters** *instance-id* — Specifies the instance ID for an IS-IS instance.

**Values** 1–31

**Default** 0

### adjacency

**Syntax** `adjacency [ip-address | ip-int-name | nbr-system-id] [detail]`

**Context** `show>router>isis`

**Description** This command displays information regarding IS-IS neighbors. When no *ip-address*, *ip-int-name*, or *nbr-system-id* are specified, then all adjacencies display.

**Parameters** *ip-address* — When specified, only adjacencies with that interface display.

**Values**

|               |                                     |
|---------------|-------------------------------------|
| ipv4-address: | a.b.c.d (host bits must be 0)       |
| ipv6-address: | x:x:x:x:x:x:x (eight 16-bit pieces) |
|               | x:x:x:x:x:d.d.d.d                   |
| x:            | [0 — FFFF]H                         |
| d:            | [0 — 255]D                          |

*ip-int-name* — When specified, only adjacencies with that interface display.

*nbr-system-id* — When specified, only the adjacency with that ID displays.

**detail** — All output displays in the detailed format.

**Output** **Standard and Detailed IS-IS Adjacency Output** — The following table describes the standard and detailed command output fields for an IS-IS adjacency.

| Label     | Description                                        |
|-----------|----------------------------------------------------|
| Interface | Interface name associated with the neighbor.       |
| System-id | Neighbor's system ID.                              |
| Level     | 1-L1 only, 2-L2 only, 3-L1 and L2.                 |
| State     | Up, down, new, one-way, initializing, or rejected. |

## Show Commands

| Label               | Description (Continued)                                                                                                                                                                                                                                      |
|---------------------|--------------------------------------------------------------------------------------------------------------------------------------------------------------------------------------------------------------------------------------------------------------|
| Hold                | Hold time remaining for the adjacency.                                                                                                                                                                                                                       |
| SNPA                | Subnetwork point of attachment, MAC address of the next hop.                                                                                                                                                                                                 |
| Circuit type        | Level on the interface L1, L2, or both.                                                                                                                                                                                                                      |
| Expires In          | Number of seconds until adjacency expires.                                                                                                                                                                                                                   |
| Priority            | Priority to become designated router.                                                                                                                                                                                                                        |
| Up/down transitions | Number of times neighbor state has changed.                                                                                                                                                                                                                  |
| Event               | Event causing last transition.                                                                                                                                                                                                                               |
| Last transition     | Time since last transition change.                                                                                                                                                                                                                           |
| Speaks              | Supported protocols (only IP).                                                                                                                                                                                                                               |
| IP address          | IP address of neighbor.                                                                                                                                                                                                                                      |
| MT enab             | Yes – The neighbor is advertising at least 1 non MTID#0.                                                                                                                                                                                                     |
| Topology            | Derived from the MT TLV in the IIH <ul style="list-style-type: none"> <li>• MT#0, MT#2 =&gt; “Topology : Unicast, IPv6-Unicast”</li> <li>• Native IPv4 or native IPv6 =&gt; “Topology : Unicast”</li> </ul> Not supported MTID's => Topology line suppressed |

### Sample Output

```
*A:Dut-A# show router isis adjacency
=====
ISIS Adjacency
=====
System ID Usage State Hold Interface MT Enab

Dut-B L1 Up 2 ip-3FFE::A0A:101 Yes
Dut-B L2 Up 2 ip-3FFE::A0A:101 Yes
Dut-F L1L2 Up 5 ies-1-3FFE::A0A:1501 Yes

Adjacencies : 3
=====
*A:Dut-A#

*A:ALA-A# show router isis adjacency 180.0.7.12
=====
ISIS Adjacency
=====
System ID Usage State Hold Interface MT Enab

asbr_east L2 Up 25 if2/5 Yes

Adjacencies : 1
=====
```



```
*A:ALA-A#
```

```
*A:ALA-A# show router isis adjacency if2/5
```

```
=====
ISIS Adjacency
=====
```

```
System ID Usage State Hold Interface

```

```
asbr_east L2 Up 20 if2/5

```

```
Adjacencies : 1
=====
```

```
*A:ALA-A#
```

```
*A:Dut-A# show router isis adjacency detail
```

```
=====
ISIS Adjacency
=====
```

```
SystemID : Dut-B SNPA : 20:81:01:01:00:01
Interface : ip-3FFE::A0A:101 Up Time : 0d 00:56:10
State : Up Priority : 64
Nbr Sys Typ : L1 L. Circ Typ : L1
Hold Time : 2 Max Hold : 2
Adj Level : L1 MT Enabled : Yes
Topology : Unicast, IPv6-Unicast
```

```
IPv6 Neighbor : FE80::2281:1FF:FE01:1
IPv4 Neighbor : 10.10.1.2
Restart Support : Disabled
Restart Status : Not currently being helped
Restart Supressed : Disabled
Number of Restarts: 0
Last Restart at : Never
```

```
SystemID : Dut-B SNPA : 20:81:01:01:00:01
Interface : ip-3FFE::A0A:101 Up Time : 0d 00:56:10
State : Up Priority : 64
Nbr Sys Typ : L2 L. Circ Typ : L2
Hold Time : 2 Max Hold : 2
Adj Level : L2 MT Enabled : Yes
Topology : Unicast, IPv6-Unicast
```

```
IPv6 Neighbor : FE80::2281:1FF:FE01:1
IPv4 Neighbor : 10.10.1.2
Restart Support : Disabled
Restart Status : Not currently being helped
Restart Supressed : Disabled
Number of Restarts: 0
Last Restart at : Never
```

```
SystemID : Dut-F SNPA : 00:00:00:00:00:00
Interface : ies-1-3FFE::A0A:1501 Up Time : 0d 01:18:34
State : Up Priority : 0
Nbr Sys Typ : L1L2 L. Circ Typ : L1L2
Hold Time : 5 Max Hold : 6
Adj Level : L1L2 MT Enabled : Yes
Topology : Unicast, IPv6-Unicast
```

## Show Commands

```
IPv6 Neighbor : FE80::2285:FFFF:FE00:0
IPv4 Neighbor : 10.10.21.6
Restart Support : Disabled
Restart Status : Not currently being helped
Restart Supressed : Disabled
Number of Restarts: 0
Last Restart at : Never
```

```
=====
*A:Dut-A#
```

```
A:Dut-A# show router isis status
```

```
=====
ISIS Status
=====
```

```
System Id : 0100.2000.1001
Admin State : Up
Ipv4 Routing : Enabled
Ipv6 Routing : Disabled
Last Enabled : 08/28/2006 10:22:17
Level Capability : L2
Authentication Check : True
Authentication Type : None
CSNP-Authentication : Enabled
HELLO-Authentication : Enabled
PSNP-Authentication : Enabled
Traffic Engineering : Enabled
Graceful Restart : Disabled
GR Helper Mode : Disabled
LSP Lifetime : 1200
LSP Wait : 1 sec (Max) 1 sec (Initial) 1 sec (Second)
Adjacency Check : loose
L1 Auth Type : none
L2 Auth Type : none
L1 CSNP-Authenticati*: Enabled
L1 HELLO-Authenticat*: Enabled
L1 PSNP-Authenticati*: Enabled
L1 Preference : 15
L2 Preference : 18
L1 Ext. Preference : 160
L2 Ext. Preference : 165
L1 Wide Metrics : Disabled
L2 Wide Metrics : Enabled
L1 LSDB Overload : Disabled
L2 LSDB Overload : Disabled
L1 LSPs : 0
L2 LSPs : 15
Last SPF : 08/28/2006 10:22:25
SPF Wait : 1 sec (Max) 10 ms (Initial) 10 ms (Second)
Export Policies : None
Area Addresses : 49.0001
=====
```

```
* indicates that the corresponding row element may have been truncated.
```

```
A:Dut-A#
```

## database

**Syntax** `database [system-id | lsp-id] [detail] [level level]`

**Context** show>router>isis

**Description** This command displays the entries in the IS-IS link state database.

**Parameters** *system-id* — Only the LSPs related to that *system-id* are listed. If no *system-id* or *lsp-id* are specified, all database entries are listed.

*lsp-id* — Only the specified LSP (hostname) is listed. If no *system-id* or *lsp-id* are specified, all database entries are listed.

**detail** — All output is displayed in the detailed format.

**level level** — Only the specified IS-IS protocol level attributes are displayed.

**Output** **IS-IS Database Output** — The following table describes the IS-IS database output.

| Label      | Description                                                                                                                                                                                                                                                                                                                                                                                                                                                                                                                                                                                                                                                                                                                                                                                                                                                                                                                                               |
|------------|-----------------------------------------------------------------------------------------------------------------------------------------------------------------------------------------------------------------------------------------------------------------------------------------------------------------------------------------------------------------------------------------------------------------------------------------------------------------------------------------------------------------------------------------------------------------------------------------------------------------------------------------------------------------------------------------------------------------------------------------------------------------------------------------------------------------------------------------------------------------------------------------------------------------------------------------------------------|
| LSP ID     | LSP IDs are auto-assigned by the originating IS-IS node. The LSP ID is comprised of three sections. The first 6 bytes is the system ID for that node, followed by a single byte value for the pseudonode generated by that router, then finally, a fragment byte which starts at zero. For example, if a router's system ID is 1800.0000.0029, the first LSP ID is 1800.0000.0029.00-00. If there are too many routes, LSP ID 1800.0000.0029.00-01 is created to contain the excess routes. If the router is the Designated Intermediate System (DIS) on a broadcast network, a pseudo-node LSP is created. Usually the internal circuit ID is used to determine the ID assigned to the pseudonode. For instance, for circuit 4, a LSP pseudonode with ID 1800.0000.0029.04-00 is created. The 7750 SR OS learns hostnames and uses the hostname in place of the system ID. An example of LDP IDs are:<br>acc_arl.00-00<br>acc_arl.00-01<br>acc_arl.04-00 |
| Sequence   | The sequence number of the LSP that allows other systems to determine if they have received the latest information from the source.                                                                                                                                                                                                                                                                                                                                                                                                                                                                                                                                                                                                                                                                                                                                                                                                                       |
| Checksum   | The checksum of the entire LSP packet.                                                                                                                                                                                                                                                                                                                                                                                                                                                                                                                                                                                                                                                                                                                                                                                                                                                                                                                    |
| Lifetime   | Amount of time, in seconds, that the LSP remains valid.                                                                                                                                                                                                                                                                                                                                                                                                                                                                                                                                                                                                                                                                                                                                                                                                                                                                                                   |
| Attributes | OV — The overload bit is set.<br><br>L1 — Specifies a Level 1 IS type.<br><br>L2 — Specifies a Level 2 IS type.<br><br>ATT — The attach bit is set. When this bit is set, the router can also act as a Level 2 router and can reach other areas.                                                                                                                                                                                                                                                                                                                                                                                                                                                                                                                                                                                                                                                                                                          |

## Show Commands

| Label          | Description (Continued)                                                                                                                                                                |
|----------------|----------------------------------------------------------------------------------------------------------------------------------------------------------------------------------------|
| LSP Count      | A sum of all the configured Level 1 and Level 2 LSPs.                                                                                                                                  |
| LSP ID         | Displays a unique identifier for each LSP composed of SysID, Pseudonode ID and LSP name.                                                                                               |
| Lifetime       | Displays the remaining time until the LSP expires.                                                                                                                                     |
| Version        | Displays the version/protocol ID extension. This value is always set to 1.                                                                                                             |
| Pkt Type       | Displays the PDU type number.                                                                                                                                                          |
| Pkt Ver        | Displays the version/protocol ID extension. This value is always set to 1.                                                                                                             |
| Max Area       | Displays the maximum number of area addresses supported.                                                                                                                               |
| Sys ID Len     | Displays the length of the system ID field (0 or 6 for 6 digits).                                                                                                                      |
| Use Len        | The actual length of the PDU.                                                                                                                                                          |
| Alloc Len      | The amount of memory space allocated for the LSP.                                                                                                                                      |
| Area Address   | Displays the area addresses to which the router is connected.                                                                                                                          |
| Supp Protocols | Displays the data protocols that are supported.                                                                                                                                        |
| IS-Hostname    | The name of the router originating the LSP.                                                                                                                                            |
| Virtual Flag   | 0 – Level 1 intermediate systems report this octet as 0 to all neighbors.<br><br>1 – Indicates that the path to a neighbor is a Level 2 virtual path used to repair an area partition. |
| Neighbor       | Displays the routers running interfaces to which the router is connected.                                                                                                              |
| Internal Reach | Displays a 32-bit metric. A bit is added for the ups and downs resulting from Level 2 to Level 1 route-leaking.                                                                        |
| IP Prefix      | Displays the IP addresses that the router knows about by externally-originated interfaces.                                                                                             |
| Metrics        | Displays a routing metric used in the IS-IS link-state calculation.                                                                                                                    |

### Sample Output

```
*A:ALA-A# show router isis database
=====
ISIS Database
=====
LSP ID Sequence Checksum Lifetime Attributes
```

```

Displaying Level 1 database

```

```
abr_dfw.00-00 0x50 0x164f 603 L1L2
Level (1) LSP Count : 1
Displaying Level 2 database

```

```
asbr_east.00-00 0x53 0xe3f5 753 L1L2
abr_dfw.00-00 0x57 0x94ff 978 L1L2
abr_dfw.03-00 0x50 0x14f1 614 L1L2
Level (2) LSP Count : 3

```

```
*A:ALA-A#
```

```
*A:Dut-B# show router isis database Dut-A.00-00 detail
```

```
=====
ISIS Database
=====
```

```
Displaying Level 1 database

```

```
Level (1) LSP Count : 0
```

```
Displaying Level 2 database

```

```
LSP ID : Dut-A.00-00 Level : L2
Sequence : 0x6 Checksum : 0xb7c4 Lifetime : 1153
Version : 1 Pkt Type : 20 Pkt Ver : 1
Attributes: L1L2 Max Area : 3
SysID Len : 6 Used Len : 311 Alloc Len : 311
```

```
TLVs :
```

```
Area Addresses:
```

```
Area Address : (2) 30.31
```

```
Supp Protocols:
```

```
Protocols : IPv4
```

```
IS-Hostname : Dut-A
```

```
Router ID :
```

```
Router ID : 10.20.1.1
```

```
I/F Addresses :
```

```
I/F Address : 10.20.1.1
```

```
I/F Address : 10.10.1.1
```

```
I/F Address : 10.10.2.1
```

```
TE IS Nbrs :
```

```
Nbr : Dut-B.01
```

```
Default Metric : 1000
```

```
Sub TLV Len : 98
```

```
IF Addr : 10.10.1.1
```

```
MaxLink BW: 100000 kbps
```

```
Resvble BW: 100000 kbps
```

```
Unresvd BW:
```

```
BW[0] : 10000 kbps
```

```
BW[1] : 40000 kbps
```

```
BW[2] : 40000 kbps
```

```
BW[3] : 40000 kbps
```

```
BW[4] : 50000 kbps
```

```
BW[5] : 50000 kbps
```

```
BW[6] : 50000 kbps
```

```
BW[7] : 10000 kbps
```

## Show Commands

```
Admin Grp : 0x0
TE Metric : 1000
SUBTLV BW CONSTS : 8
 BW Model : 1
 BC[0]: 10000 kbps
 BC[1]: 0 kbps
 BC[2]: 40000 kbps
 BC[3]: 0 kbps
 BC[4]: 0 kbps
 BC[5]: 50000 kbps
 BC[6]: 0 kbps
 BC[7]: 0 kbps
TE IP Reach :
 Default Metric : 0
 Control Info: , prefLen 32
 Prefix : 10.20.1.1
 Default Metric : 1000
 Control Info: , prefLen 24
 Prefix : 10.10.1.0
 Default Metric : 1000
 Control Info: , prefLen 24
 Prefix : 10.10.2.0

Level (2) LSP Count : 1
=====
*A:Dut-B#
```

## hostname

**Syntax** hostname

**Context** show>router>isis

**Description** This command displays the hostname database. There are no options or parameters.

**Output** **IS-IS Hostname Output** — The following table describes output fields for IS-IS hostname output.

| Label     | Description                                  |
|-----------|----------------------------------------------|
| System-id | System identifier mapped to hostname.        |
| Hostname  | Hostname for the specific <i>system-id</i> . |
| Type      | The type of entry (static or dynamic).       |

### Sample Output

```
A:ALA-A# show router isis hostname
=====
Hosts
=====
System Id Hostname

1800.0000.0002 core_west
1800.0000.0005 core_east
```

```

1800.0000.0008 asbr_west
1800.0000.0009 asbr_east
1800.0000.0010 abr_sjc
1800.0000.0011 abr_lax
1800.0000.0012 abr_nyc
1800.0000.0013 abr_dfw
1800.0000.0015 dist_oak
1800.0000.0018 dist_nj
1800.0000.0020 acc_nj
1800.0000.0021 acc_ri
1800.0000.0027 dist_arl
1800.0000.0028 dist_msq
1800.0000.0029 acc_arl
1800.0000.0030 acc_msq
=====
A:ALA-A#

```

## interface

**Syntax** `interface [ip-int-name | ip-address] [detail]`

**Context** `show>router>isis`

**Description** This command shows IS-IS interface information. When no *ip-addr* or the *ip-int-name* is specified, all interfaces are listed.

**Parameters** *ip-address* — Only displays the interface information associated with the specified IP address.

| Values | ipv4-address | a.b.c.d (host bits must be 0)       |
|--------|--------------|-------------------------------------|
|        | ipv6-address | x:x:x:x:x:x:x (eight 16-bit pieces) |
|        |              | x:x:x:x:x:d.d.d.d                   |
|        |              | x: [0 — FFFF]H                      |
|        |              | d: [0 — 255]D                       |

*ip-int-name* — Only displays the interface information associated with the specified IP interface name.

**detail** — All output is given in the detailed format.

**Output** **IS-IS Interface Output** — The following table describes IS-IS interface output fields.

| Label        | Description                                                                            |
|--------------|----------------------------------------------------------------------------------------|
| Interface    | The interface name.                                                                    |
| Level        | Specifies the interface level (1, 2, or 1 and 2).                                      |
| CirID        | Specifies the circuit identifier.                                                      |
| Oper State   | Up — The interface is operationally up.<br>Down — The interface is operationally down. |
| L1/L2 Metric | Interface metric for Level 1 and Level 2, if none are set to 0.                        |

## Show Commands

### Sample Output

```
A:ALA-A# show router isis interface
=====
ISIS Interfaces
=====
Interface Level CircID Oper State L1/L2 Metric

system L1L2 1 Up 10/10
if2/1 L2 8 Up -/10
if2/2 L1 5 Up 10/-
if2/3 L1 6 Up 10/-
if2/4 L1 7 Up 10/-
if2/5 L2 2 Up -/10
lag-1 L2 3 Up -/10
if2/8 L2 4 Up -/10

Interfaces : 8
=====
A:ALA-A#
```

```
A:SetupCLI# show router isis interface detail
=====
ISIS Interfaces
=====
Interface : system Level Capability: L2
Oper State : Up Admin State : Up
Auth Type : None Auth State : Enabled
Circuit Id : 1 Retransmit Int. : 65535
Type : Pt-to-Pt LSP Pacing Int. : 100
CSNP Int. : 22
Mesh Group : 54
Bfd Enabled : Yes
Te Metric : 0 Te State : Down
Admin Groups : None
Ldp Sync : outOfService Ldp Sync Wait : Disabled
Ldp Timer State: Disabled Ldp Tm Left : 0
Route Tag : 4294967295 LFA : Included

Level : 2 Adjacencies : 0
Auth Type : None Metric : 0
Hello Timer : 9 Hello Mult. : 3
Priority : 64 IPv6-Ucast-Met : 0
Passive : No

Interface : ip_if_1 Level Capability: L1L2
Oper State : Down Admin State : Down
Auth Type : None Auth State : Enabled
Circuit Id : 5 Retransmit Int. : 65535
Type : Pt-to-Pt LSP Pacing Int. : 100
CSNP Int. : 22
Mesh Group : 54
Bfd Enabled : Yes
Te Metric : 0 Te State : Down
Admin Groups : None
Ldp Sync : outOfService Ldp Sync Wait : Disabled
Ldp Timer State: Disabled Ldp Tm Left : 0
```



```

Route Tag : 4294967295 LFA : Included

Level : 1 Adjacencies : 0
Auth Type : Password Metric : 1
Hello Timer : 20000 Hello Mult. : 100
Priority : 1 IPv6-Ucast-Met : 10
Passive : Yes

Level : 2 Adjacencies : 0
Auth Type : Password Metric : 1
Hello Timer : 20000 Hello Mult. : 100
Priority : 1 IPv6-Ucast-Met : 10

Interface : LOA1 Level Capability: L1L2
Oper State : Down Admin State : Up
Auth Type : None Auth State : Enabled
Circuit Id : 49 Retransmit Int. : 5
Type : Broadcast LSP Pacing Int. : 100
CSNP Int. : 10
Mesh Group : Inactive
Bfd Enabled : No
Te Metric : 0 Te State : Down
Admin Groups : None
Ldp Sync : outOfService Ldp Sync Wait : Disabled
Ldp Timer State: Disabled Ldp Tm Left : 0
Route Tag : None LFA : Excluded

Level : 1 Adjacencies : 0
Desg. IS : 0000.0000.0000 Metric : 1000
Auth Type : None Hello Mult. : 3
Hello Timer : 9 IPv6-Ucast-Met : 1000
Priority : 64
Passive : No

Level : 2 Adjacencies : 0
Desg. IS : 0000.0000.0000 Metric : 1000
Auth Type : None Hello Mult. : 3
Hello Timer : 9 IPv6-Ucast-Met : 1000
Priority : 64
Passive : No

```

## lfa-coverage

**Syntax** `lfa-coverage`

**Context** `show>router>isis`

**Description** This command displays IS-IS LFA coverage information.

### Sample Output

```
*A:SR# show router isis lfa-coverage
```

## Show Commands

```
=====
LFA Coverage
=====
Topology Level Node IPv4

IPV4 Unicast L1 4/4(100%) 826/826(100%)
IPV4 Unicast L2 2/2(100%) 826/826(100%)
IPV6 Unicast L1 3/3(100%) 0/0(0%)
IPV6 Unicast L2 0/0(0%) 0/0(0%)
=====
*A:SR#

*A:SRR>config>router>isis# show router isis lfa-coverage
=====
LFA Coverage
=====
Topology Level Node IPv4 IPv6

IPV4 Unicast L1 3/4(75%) 1484/1975(75%) 0/0(0%)
IPV4 Unicast L2 3/3(100%) 1484/1975(75%) 0/0(0%)
=====
*A:SRR>config>router>isis#
```

## neighbor

**Syntax** neighbor

**Context** show>router>isis

**Description** This command displays neighboring route information in the IS-IS route table.

### Sample Output

```
A:linus-212# show router isis neighbor

=====
Topology Table
=====
Node Interface Nexthop

IS-IS IP paths (MT-ID 0), Level 1

linus-211.00 ab linus-211
linus-216.00 ab linus-211
linus-216.01 ab linus-211

IS-IS IP paths (MT-ID 0), Level 2

linus-211.00 ab linus-211
linus-216.00 ab linus-211
linus-216.01 ab linus-211
=====
```

## routes

**Syntax** `routes [ipv4-unicast | ipv6-unicast | mt mt-id-number | alternative | ip-prefix[/prefix-length]]`

**Context** `show>router>isis`

**Description** This command displays the routes in the IS-IS route table.

**Parameters** **ipv4-unicast** — Displays IPv4 unicast parameters.

**ipv6-unicast** — Displays IPv6 unicast parameters.

**mt *mt-id-number*** — Displays multi-topology parameters.

**Values** 0, 2

**alternative** — Displays LFA details.

**Output** **IS-IS Route Output** — The following table describes IS-IS route output fields.

| Label     | Description                                                                        |
|-----------|------------------------------------------------------------------------------------|
| Prefix    | The route prefix and mask.                                                         |
| Metric MT | The route's metric.                                                                |
| Lvl/Type  | Specifies the level (1 or 2) and the route type, Internal (Int) or External (Ext). |
| Version   | SPF version that generated route.                                                  |
| Nexthop   | System ID of nexthop, give hostname if possible.                                   |
| Hostname  | Hostname for the specific <i>system-id</i> .                                       |

**Sample Output**

```
*A:Dut-B# show router isis routes
=====
Route Table
=====
Prefix [Flags] Metric Lvl/Typ Ver. SysID/Hostname
 NextHop MT AdminTag

10.20.1.2/32 0 1/Int. 3 Dut-B
 0.0.0.0 0
10.20.1.3/32 [L] 10 2/Int. 2 Dut-C
 10.20.3.3 0
10.20.1.4/32 10 2/Int. 3 Dut-D
 10.20.4.4 0
10.20.1.5/32 20 2/Int. 3 Dut-C
 10.20.3.3 0
10.20.1.6/32 20 2/Int. 3 Dut-D
 10.20.4.4 0
10.20.3.0/24 10 1/Int. 3 Dut-B
 0.0.0.0 0
10.20.4.0/24 10 1/Int. 3 Dut-B
```

## Show Commands

```

0.0.0.0 0 0
10.20.5.0/24 20 2/Int. 2 Dut-C
 10.20.3.3 0 0
10.20.6.0/24 20 2/Int. 4 Dut-D
 10.20.4.4 0 0
10.20.9.0/24 20 2/Int. 3 Dut-D
 10.20.4.4 0 0
10.20.10.0/24 30 2/Int. 3 Dut-C
 10.20.3.3 0 0

Routes : 11
Flags: L = LFA nexthop available
=====
*A:Dut-B#

*A:Dut-B# show router isis routes alternative

Route Table
=====
Prefix [Flags] Metric Lvl/Typ Ver. SysID/Hostname
NextHop MT AdminTag
Alt-Nexthop Alt-Metric

0 1/Int. 3 Dut-B-----10.20.1.2/32
 0.0.0.0 0 0
10.20.1.3/32 10 2/Int. 2 Dut-C
 10.20.3.3 0 0
 10.20.3.3 (lfa) 15
10.20.1.4/32 10 2/Int. 3 Dut-D
 10.20.4.4 0 0
10.20.1.5/32 20 2/Int. 3 Dut-C
 10.20.3.3 0 0
10.20.1.6/32 20 2/Int. 3 Dut-D
 10.20.4.4 0 0
10.20.3.0/24 10 1/Int. 3 Dut-B
 0.0.0.0 0 0
10.20.4.0/24 10 1/Int. 3 Dut-B
 0.0.0.0 0 0
10.20.5.0/24 20 2/Int. 2 Dut-C
 10.20.3.3 0 0
10.20.6.0/24 20 2/Int. 4 Dut-D
 10.20.4.4 0 0
10.20.9.0/24 20 2/Int. 3 Dut-D
 10.20.4.4 0 0
10.20.10.0/24 30 2/Int. 3 Dut-C
 10.20.3.3 0 0

-----Routes : 11
Flags: LFA = Loop-Free Alternate nexthop
=====
*A:Dut-B#

*A:Dut-A# show router isis routes
=====
Route Table
=====
Prefix Metric Lvl/Typ Ver. SysID/Hostname
NextHop MT

```

```

10.10.1.0/24 10 1/Int. 5 Dut-A
 0.0.0.0 0
10.10.3.0/24 20 1/Int. 137 Dut-B
 10.10.1.2 0
10.10.4.0/24 20 1/Int. 137 Dut-B
 10.10.1.2 0
10.10.5.0/24 30 1/Int. 137 Dut-B
 10.10.1.2 0
10.10.9.0/24 60 1/Int. 52 Dut-F
 10.10.21.6 0
10.10.10.0/24 70 1/Int. 52 Dut-F
 10.10.21.6 0
10.10.12.0/24 20 1/Int. 137 Dut-B
 10.10.1.2 0
10.10.13.0/24 10 1/Int. 7 Dut-A
 0.0.0.0 0
10.10.14.0/24 20 1/Int. 52 Dut-F
 10.10.21.6 0
10.10.15.0/24 30 1/Int. 137 Dut-B
 10.10.1.2 0
10.10.16.0/24 30 1/Int. 137 Dut-B
 10.10.1.2 0
10.10.21.0/24 10 1/Int. 48 Dut-A
 0.0.0.0 0
10.10.22.0/24 30 1/Int. 137 Dut-B
 10.10.1.2 0
10.20.1.1/32 0 1/Int. 10 Dut-A
 0.0.0.0 0
10.20.1.2/32 10 1/Int. 137 Dut-B
 10.10.1.2 0
10.20.1.3/32 20 1/Int. 137 Dut-B
 10.10.1.2 0
10.20.1.4/32 20 1/Int. 137 Dut-B
 10.10.1.2 0
10.20.1.5/32 30 1/Int. 137 Dut-B
 10.10.1.2 0
10.20.1.6/32 10 1/Int. 52 Dut-F
 10.10.21.6 0
3FFE::A0A:100/120 10 1/Int. 5 Dut-A
 :: 0
10.10.1.0/24 10 1/Int. 65 Dut-A
 0.0.0.0 2
10.10.13.0/24 10 1/Int. 65 Dut-A
 0.0.0.0 2
10.10.21.0/24 10 1/Int. 65 Dut-A
 0.0.0.0 2
10.20.1.1/32 0 1/Int. 65 Dut-A
 0.0.0.0 2
3FFE::A0A:100/120 10 1/Int. 65 Dut-A
 :: 2
3FFE::A0A:300/120 20 1/Int. 116 Dut-B
 FE80::2281:1FF:FE01:1-"ip-3FFE::A0A:101" 2
3FFE::A0A:400/120 20 1/Int. 116 Dut-B
 FE80::2281:1FF:FE01:1-"ip-3FFE::A0A:101" 2
3FFE::A0A:500/120 30 1/Int. 130 Dut-B
 FE80::2281:1FF:FE01:1-"ip-3FFE::A0A:101" 2
3FFE::A0A:900/120 60 1/Int. 71 Dut-F
 FE80::2285:FFFF:FE00:0-"ies-1-3FFE::A0A:1501" 2

```

## Show Commands

```

3FFE::A0A:A00/120 70 1/Int. 71 Dut-F
 FE80::2285:FFFF:FE00:0-"ies-1-3FFE::A0A:1501" 2
3FFE::A0A:C00/120 20 1/Int. 116 Dut-B
 FE80::2281:1FF:FE01:1-"ip-3FFE::A0A:101" 2
3FFE::A0A:D00/120 10 1/Int. 65 Dut-A
 :: 2
3FFE::A0A:E00/120 20 1/Int. 71 Dut-F
 FE80::2285:FFFF:FE00:0-"ies-1-3FFE::A0A:1501" 2
3FFE::A0A:F00/120 30 1/Int. 130 Dut-B
 FE80::2281:1FF:FE01:1-"ip-3FFE::A0A:101" 2
3FFE::A0A:1000/120 30 1/Int. 130 Dut-B
 FE80::2281:1FF:FE01:1-"ip-3FFE::A0A:101" 2
3FFE::A0A:1500/120 10 1/Int. 65 Dut-A
 :: 2
3FFE::A0A:1600/120 30 1/Int. 127 Dut-B
 FE80::2281:1FF:FE01:1-"ip-3FFE::A0A:101" 2
3FFE::A14:101/128 0 1/Int. 65 Dut-A
 :: 2
3FFE::A14:102/128 10 1/Int. 116 Dut-B
 FE80::2281:1FF:FE01:1-"ip-3FFE::A0A:101" 2
3FFE::A14:103/128 20 1/Int. 130 Dut-B
 FE80::2281:1FF:FE01:1-"ip-3FFE::A0A:101" 2
3FFE::A14:104/128 20 1/Int. 127 Dut-B
 FE80::2281:1FF:FE01:1-"ip-3FFE::A0A:101" 2
3FFE::A14:105/128 30 1/Int. 130 Dut-B
 FE80::2281:1FF:FE01:1-"ip-3FFE::A0A:101" 2
3FFE::A14:106/128 10 1/Int. 71 Dut-F
 FE80::2285:FFFF:FE00:0-"ies-1-3FFE::A0A:1501" 2

Routes : 43
=====
*A:Dut-A#

*A:SRR# show router isis routes 1.1.1.0/24
=====
Route Table
=====
Prefix[Flags] Metric Lvl/Typ Ver. SysID/Hostname
 NextHop MT AdminTag

1.1.1.0/24 [L] 7540 1/Int. 6109 SRL
 60.60.1.1 0 0

No. of Routes: 1
Flags: L = LFA nexthop available
=====
*A:SRR# show router isis routes 1.1.1.0/24 alternative
=====
Route Table
=====
Prefix[Flags] Metric Lvl/Typ Ver. SysID/Hostname
 NextHop MT AdminTag
 Alt-Nexthop Alt-Metric Alt-Type

1.1.1.0/24 7550 1/Int. 6114 SRL
 60.60.1.1 0 0
 11.22.12.4 (LFA) 16784764 linkProtection

No. of Routes: 1

```

```

Flags: LFA = Loop-Free Alternate nexthop
=====
*A:SRR#

*A:SRR# show router isis routes 1.1.1.0/24
=====
Route Table
=====
Prefix[Flags] Metric Lvl/Typ Ver. SysID/Hostname
NextHop MT AdminTag

1.1.1.0/24 [L] 7540 1/Int. 6109 SRL
 60.60.1.1 0 0

No. of Routes: 1
Flags: L = LFA nexthop available
=====
*A:SRR# show router isis routes 1.1.1.0/24 alternative
=====
Route Table
=====
Prefix[Flags] Metric Lvl/Typ Ver. SysID/Hostname
NextHop MT AdminTag
Alt-Nexthop Alt-Metric Alt-Type

1.1.1.0/24 7550 1/Int. 6114 SRL
 60.60.1.1 0 0
 11.22.12.4 (LFA) 16784764 linkProtection

No. of Routes: 1
Flags: LFA = Loop-Free Alternate nexthop
=====
*A:SRR#

```

## spf

**Syntax** `spf [detail] [lfa]`

**Context** `show>router>isis`

**Description** This command displays information regarding SPF calculation.

**Output** **Router ISIS Output** — The following table describes the output fields for ISIS SPF.

| Label     | Description                                |
|-----------|--------------------------------------------|
| Node      | The route node and mask.                   |
| Interface | The outgoing interface name for the route. |
| Metric    | The route's metric.                        |
| Nexthop   | The system ID of nexthop or hostname.      |

| Label | Description (Continued)                                                                           |
|-------|---------------------------------------------------------------------------------------------------|
| SNPA  | The Subnetwork Points of Attachment (SNPA) where a router is physically attached to a subnetwork. |

**Sample Output**

```
linus-212>show>router>isis# show router isis spf
=====
Path Table
=====
Node Interface Nexthop

linus-211.00 ab linus-211
x linux-222 *
linus-216.00 ab linus-211
linus-216.00 ab linus-211
linus-216.01 ab linus-211
=====
```

```
A:ALA-A# show router isis spf
=====
Path Table
=====
Node Interface Nexthop

abr_sjc.00 if2/2 dist_oak
abr_sjc.00 if2/3 dist_nj
dist_oak.00 if2/2 dist_oak
dist_nj.00 if2/3 dist_nj
acc_nj.00 if2/3 dist_nj
acc_ri.00 if2/3 dist_nj
core_west.00 if2/8 core_west
core_east.00 lag-1 core_east
asbr_west.00 if2/8 core_west
asbr_east.00 if2/5 asbr_east
abr_sjc.00 lag-1 core_east
abr_sjc.00 if2/8 core_west
abr_lax.00 lag-1 core_east
abr_lax.00 if2/8 core_west
abr_dfw.00 if2/5 asbr_east
abr_dfw.00 lag-1 core_east
abr_dfw.00 if2/8 core_west
dist_arl.00 if2/5 asbr_east
dist_arl.00 lag-1 core_east
dist_arl.00 if2/8 core_west
dist_msq.00 if2/5 asbr_east
dist_msq.00 lag-1 core_east
dist_msq.00 if2/8 core_west
acc_arl.00 if2/5 asbr_east
acc_arl.00 lag-1 core_east
acc_arl.00 if2/8 core_west
acc_msq.00 if2/5 asbr_east
acc_msq.00 lag-1 core_east
acc_msq.00 if2/8 core_west
acc_msq.03 if2/5 asbr_east
```



```

acc_msq.03 lag-1 core_east
acc_msq.03 if2/8 core_west
acc_msq.04 if2/5 asbr_east
acc_msq.04 lag-1 core_east
acc_msq.04 if2/8 core_west
=====

```

A:ALA-A#

A:ALA-A# show router isis spf detail

=====  
Path Table  
=====

```

Node : abr_sjc.00 Metric : 20
Interface : if2/2 SNPA : 00:00:00:00:00:00
NextHop : dist_oak

```

```

Node : abr_sjc.00 Metric : 20
Interface : if2/3 SNPA : 00:00:00:00:00:00
NextHop : dist_nj

```

```

Node : dist_oak.00 Metric : 10
Interface : if2/2 SNPA : 00:00:00:00:00:00
NextHop : dist_oak

```

```

Node : dist_nj.00 Metric : 10
Interface : if2/3 SNPA : 00:00:00:00:00:00
NextHop : dist_nj

```

```

Node : acc_nj.00 Metric : 20
Interface : if2/3 SNPA : 00:00:00:00:00:00
NextHop : dist_nj

```

```

Node : acc_ri.00 Metric : 20
Interface : if2/3 SNPA : 00:00:00:00:00:00
NextHop : dist_nj

```

```

Node : core_west.00 Metric : 10
Interface : if2/8 SNPA : 00:00:00:00:00:00
NextHop : core_west

```

...

=====  
A:ALA-A#

\*A:SRR>config>router>isis# show router isis spf lfa detail

=====  
Path Table  
=====

Level 1

```

Node : SRL.00 Metric : 1000
Interface : aps-10 SNPA : n/a
NextHop : SRL

```

```

LFA intf : sru4-3 LFA Metric : 16778214
LFA nh : SRU4 LFA type : linkProtection

```

```

Node : SRU4.00 Metric : 1000

```

## Show Commands

```
Interface : sru4-3 SNPA : n/a
Nexthop : SRU4

LFA intf : aps-11 LFA Metric : 16777214
LFA nh : SRU4 LFA type : linkProtection

Node : ESS-7.00 Metric : 16779214
Interface : aps-10 SNPA : n/a
Nexthop : SRL

LFA intf : sru4-3 LFA Metric : 33555428
LFA nh : SRU4 LFA type : nodeProtection

Node : ESS-7.09 Metric : 16778214
Interface : sru4-3 SNPA : n/a
Nexthop : SRU4

Node : ESS-7.0A Metric : 16778214
Interface : sru4-3 SNPA : n/a
Nexthop : SRU4

Node : ESS-7.0B Metric : 16778214
Interface : sru4-3 SNPA : n/a
Nexthop : SRU4

Node : SRC.00 Metric : 1000
Interface : src-asap-2 SNPA : n/a
Nexthop : SRC

Node : SRC.01 Metric : 2000
Interface : aps-10 SNPA : n/a
Nexthop : SRL

Node : SRC.02 Metric : 16778214
Interface : src-asap-2 SNPA : n/a
Nexthop : SRC

Node : SRC.03 Metric : 1063
Interface : aps-10 SNPA : n/a
Nexthop : SRL

Level 2

Node : SRL.00 Metric : 1000
Interface : aps-1 SNPA : n/a
Nexthop : SRL

Node : SRL.00 Metric : 1000
Interface : if-30.30.1.2 SNPA : n/a
Nexthop : SRL

Node : SRL.00 Metric : 1000
Interface : if-40.40.1.2 SNPA : n/a
Nexthop : SRL

Node : SRL.09 Metric : 2000
Interface : aps-1 SNPA : n/a
Nexthop : SRL
```

```

Node : SRL.09 Metric : 2000
Interface : if-30.30.1.2 SNPA : n/a
NextHop : SRL

Node : SRL.09 Metric : 2000
Interface : if-40.40.1.2 SNPA : n/a
NextHop : SRL

Node : SRL.0A Metric : 2000
Interface : aps-1 SNPA : n/a
NextHop : SRL

Node : SRL.0A Metric : 2000
Interface : if-30.30.1.2 SNPA : n/a
NextHop : SRL

Node : SRL.0A Metric : 2000
Interface : if-40.40.1.2 SNPA : n/a
NextHop : SRL

Node : SRU4.00 Metric : 2000
Interface : aps-1 SNPA : n/a
NextHop : SRL

Node : SRU4.00 Metric : 2000
Interface : if-30.30.1.2 SNPA : n/a
NextHop : SRL

Node : SRU4.00 Metric : 2000
Interface : if-40.40.1.2 SNPA : n/a
NextHop : SRL

Node : SRU4.14 Metric : 16778214
Interface : germ-1 SNPA : n/a
NextHop : SROne

Node : ESS-7.00 Metric : 1000
Interface : ess-7-1 SNPA : 00:16:4d:c1:25:e4
NextHop : ESS-7

 LFA intf : ess-7-2 LFA Metric : 16777214
 LFA nh : ESS-7 LFA type : linkProtection

Node : ESS-7.05 Metric : 16778214
Interface : aps-1 SNPA : n/a
NextHop : SRL

Node : ESS-7.05 Metric : 16778214
Interface : if-30.30.1.2 SNPA : n/a
NextHop : SRL

Node : ESS-7.05 Metric : 16778214
Interface : if-40.40.1.2 SNPA : n/a
NextHop : SRL

Node : ESS-7.05 Metric : 16778214
Interface : ess-7-1 SNPA : 00:16:4d:c1:25:e4
NextHop : ESS-7

```

## Show Commands

```
Node : ESS-7.06 Metric : 16778214
Interface : aps-1 SNPA : n/a
Nexthop : SRL

Node : ESS-7.06 Metric : 16778214
Interface : if-30.30.1.2 SNPA : n/a
Nexthop : SRL

Node : ESS-7.06 Metric : 16778214
Interface : if-40.40.1.2 SNPA : n/a
Nexthop : SRL

Node : ESS-7.06 Metric : 16778214
Interface : ess-7-1 SNPA : 00:16:4d:c1:25:e4
Nexthop : ESS-7

Node : ESS-7.0C Metric : 16778214
Interface : ess-7-1 SNPA : 00:16:4d:c1:25:e4
Nexthop : ESS-7

Node : ESS-7.0D Metric : 16778214
Interface : ess-7-1 SNPA : 00:16:4d:c1:25:e4
Nexthop : ESS-7

Node : ESS-7.0E Metric : 16778214
Interface : ess-7-1 SNPA : 00:16:4d:c1:25:e4
Nexthop : ESS-7

Node : ESS-7.12 Metric : 16778214
Interface : ess-7-1 SNPA : 00:16:4d:c1:25:e4
Nexthop : ESS-7

Node : ESS-7.12 Metric : 16778214
Interface : germ-1 SNPA : n/a
Nexthop : SROne

Node : SRC.00 Metric : 1000
Interface : src-asap-1 SNPA : n/a
Nexthop : SRC

LFA intf : aps-1 LFA Metric : 2063
LFA nh : SRL LFA type : linkProtection

Node : SRC.05 Metric : 16778214
Interface : src-asap-1 SNPA : n/a
Nexthop : SRC

Node : SRC.06 Metric : 16778214
Interface : src-asap-1 SNPA : n/a
Nexthop : SRC

Node : SRC.07 Metric : 16778214
Interface : src-asap-1 SNPA : n/a
Nexthop : SRC

Node : SRC.08 Metric : 16778214
Interface : src-asap-1 SNPA : n/a
Nexthop : SRC
```

```

Node : SRC.09 Metric : 16778214
Interface : src-asap-1 SNPA : n/a
Nexthop : SRC

Node : SRC.0A Metric : 16778214
Interface : src-asap-1 SNPA : n/a
Nexthop : SRC

Node : SRC.0B Metric : 16778214
Interface : src-asap-1 SNPA : n/a
Nexthop : SRC

Node : SRC.0C Metric : 16778214
Interface : src-asap-1 SNPA : n/a
Nexthop : SRC

Node : SRC.0D Metric : 16778214
Interface : src-asap-1 SNPA : n/a
Nexthop : SRC

Node : SRC.0E Metric : 16778214
Interface : src-asap-1 SNPA : n/a
Nexthop : SRC

Node : SROne.00 Metric : 1000
Interface : germ-1 SNPA : n/a
Nexthop : SROne

LFA intf : aps-1 LFA Metric : 2000
LFA nh : SRL LFA type : linkProtection

```

```

=====
*A:SRR>config>router>isis#

```

## spf-log

**Syntax** `spf-log [detail]`

**Context** `show>router>isis`

**Description** Displays the IS-IS SPF log information.

**Parameters** `detail` — Displays detailed logged information.

**Output** **Router ISIS SFP Log Output** — The following table describes the ISIS SPF log output fields.

| Label    | Description                                                                     |
|----------|---------------------------------------------------------------------------------|
| When     | Displays the timestamp when the SPF run started on the system                   |
| Duration | Displays the time (in hundredths of a second) required to complete the SPF run. |
| L1 Nodes | Displays the number of level 1 nodes involved in the SPF run.                   |

## Show Commands

| Label       | Description (Continued)                                               |
|-------------|-----------------------------------------------------------------------|
| L2 Nodes    | Displays the number of level 2 nodes involved in the SPF run.         |
| Event Count | Displays the number of SPF events that triggered the SPF calculation. |
| Log Entries | The total number of log entries.                                      |

### Sample Output

```
*A:Dut-A# show router isis spf-log
=====
ISIS SPF Log
=====
When Duration L1 Nodes L2 Nodes Event Count Type

02/20/2012 08:57:33 <0.01s 6 6 141 Reg
02/20/2012 08:57:34 <0.01s 14 14 20 Reg
02/20/2012 08:57:34 <0.01s 28 28 20 Lfa
02/20/2012 08:57:36 <0.01s 14 14 18 Reg
02/20/2012 08:57:36 <0.01s 28 28 18 Lfa
02/20/2012 08:57:44 <0.01s 14 14 3 Reg
02/20/2012 08:57:45 <0.01s 28 28 3 Lfa

Log Entries : 7
=====
*A:Dut-A#

A:SetupCLI# show router isis spf-log detail
=====
ISIS SPF Log
=====
When : 10/01/2011 03:40:25 Duration : <0.01s
L1 Nodes : 1 L2 Nodes : 1
Trigger LSP: SetupCLI.00-00 Event Count : 78
SPF Type : Reg
Reason : LSPCONTENT

When : 10/01/2011 03:40:26 Duration : <0.01s
L1 Nodes : 1 L2 Nodes : 1
Trigger LSP: SetupCLI.00-00 Event Count : 1
SPF Type : Reg
Reason : LSPCONTENT

When : 10/01/2011 03:40:25 Duration : <0.01s
L1 Nodes : 1 L2 Nodes : 1
Trigger LSP: SetupCLI.00-00 Event Count : 25
SPF Type : Reg
Reason : NEWAREA NEWREACH LSPCONTENT MANUALREQ

When : 10/01/2011 03:40:27 Duration : <0.01s
L1 Nodes : 1 L2 Nodes : 1
Trigger LSP: SetupCLI.00-00 Event Count : 1
SPF Type : Reg
Reason : LSPCONTENT
```

```

When : 10/01/2011 03:40:27 Duration : <0.01s
L1 Nodes : 0 L2 Nodes : 0
Trigger LSP: SetupCLI.00-00 Event Count : 1
SPF Type : Lfa
Reason : LSPCONTENT

```

```

When : 10/01/2011 03:40:25 Duration : <0.01s
L1 Nodes : 1 L2 Nodes : 1
Trigger LSP: SetupCLI.00-00 Event Count : 75
SPF Type : Reg
Reason : LSPCONTENT

```

```

When : 10/01/2011 03:40:27 Duration : <0.01s
L1 Nodes : 1 L2 Nodes : 1
Trigger LSP: SetupCLI.00-00 Event Count : 1
SPF Type : Reg
Reason : LSPCONTENT

```

```

=====
A:SetupCLI#

```

```

A:ALA-48# show router isis spf-log

```

```

=====
ISIS SPF Log

```

```

=====
When Duration L1 Nodes L2 Nodes Event Count

01/30/2007 11:01:54 <0.01s 1 1 3
=====

```

```

Log Entries : 1

```

```

=====
A:ALA-48#

```

## statistics

**Syntax** **statistics**

**Context** show>router>isis

**Description** This command displays information regarding IS-IS traffic statistics.

**Output** **IS-IS Statistics Output** — This table describes IS-IS statistics output fields.

| Label           | Description                                                          |
|-----------------|----------------------------------------------------------------------|
| Purge Initiated | The number of times purges have been initiated.                      |
| SPF Runs        | The number of times shortest path first calculations have been made. |
| LSP Regens      | The count of LSP regenerations.                                      |
| Requests        | The number of CSPF requests made to the protocol.                    |

## Show Commands

| Label         | Description (Continued)                                                                         |
|---------------|-------------------------------------------------------------------------------------------------|
| Paths Found   | The number of responses to CSPF requests for which paths satisfying the constraints were found. |
| PDU Type      | The PDU type.                                                                                   |
| Received      | The count of link state PDUs received by this instance of the protocol.                         |
| Processed     | The count of link state PDUs processed by this instance of the protocol.                        |
| Dropped       | The count of link state PDUs dropped by this instance of the protocol.                          |
| Sent          | The count of link state PDUs sent out by this instance of the protocol.                         |
| Retransmitted | The count of link state PDUs that had to be retransmitted by this instance of the protocol.     |

### Sample Output

```
*A:SRR>config>router>isis# show router isis statistics
=====
ISIS Statistics
=====
ISIS Instance : 0 SPF Runs : 6274
Purge Initiated : 2654 LSP Regens. : 250706

CSPF Statistics
Requests : 4991 Request Drops : 0
Paths Found : 20 Paths Not Found : 4971

LFA Statistics
LFA Runs : 6274

PDU Type Received Processed Dropped Sent Retransmitted

LSP 9997718 9997718 0 7060383 0
IIH 149110 149110 0 171964 0
CSNP 411712 411712 0 204861 0
PSNP 528654 528654 0 615952 0
Unknown 0 0 0 0 0
=====
*A:SRR>config>router>isis#
```



## status

**Syntax** status**Context** show>router>isis**Description** This command displays information regarding IS-IS status.**Output** **IS-IS Status Output** — The following table describes IS-IS status output fields.

| Label                | Description                                                                                                                                                                   |
|----------------------|-------------------------------------------------------------------------------------------------------------------------------------------------------------------------------|
| System-id            | Neighbor system ID.                                                                                                                                                           |
| Admin State          | Up — IS-IS is administratively up.<br>Down — IS-IS is administratively down.                                                                                                  |
| Ipv4 Routing         | Enabled — IPv4 routing is enabled.<br>Disabled — IPv4 routing is disabled.                                                                                                    |
| Ipv6 Routing         | Disabled — IPv6 routing is disabled.<br>Enabled, Native — IPv6 routing is enabled.<br>Enabled, Multi-topology — Multi-topology TLVs for IPv6 routing is enabled.              |
| Multi-topology       | Disabled — Multi-topology TLVs for IPv6 routing is disabled.<br>Enabled — Multi-topology TLVs for IPv6 routing is enabled.                                                    |
| Last Enabled         | The date/time when IS-IS was last enabled in the router.                                                                                                                      |
| Level Capability     | The routing level for the IS-IS routing process.                                                                                                                              |
| Authentication Check | True — All IS-IS mismatched protocol packets are rejected.<br>False — Authentication is performed on received IS-IS protocol packets but mismatched packets are not rejected. |
| Authentication Type  | The method of authentication used to verify the authenticity of packets sent by neighboring routers on an IS-IS interface.                                                    |
| Traffic Engineering  | Enabled — TE is enabled for the router.<br>Disabled — TE is disabled so that TE metrics are not generated and are ignored when received by this node.                         |
| Graceful Restart     | Enabled — Graceful restart is enabled for this instance of IS-IS on the router.                                                                                               |

## Show Commands

| Label                | Description (Continued)                                                                                                                    |
|----------------------|--------------------------------------------------------------------------------------------------------------------------------------------|
|                      | Disabled – Graceful restart capability is disabled for this instance of IS-IS on the router.                                               |
| Ldp Sync Admin State | Indicates whether the IGP-LDP synchronization feature is enabled or disabled on all interfaces participating in the OSPF routing protocol. |

### Sample Output

```
A:SetupCLI# show router isis status
=====
ISIS Status
=====
System Id : 0100.2003.0040
Admin State : Up
Ipv4 Routing : Enabled
Ipv6 Routing : Disabled
Last Enabled : 10/01/2011 04:11:47
Level Capability : L1L2
Authentication Check : True
Authentication Type : MD5
CSNP-Authentication : Enabled
HELLO-Authentication : Enabled
PSNP-Authentication : Enabled
Traffic Engineering : Enabled
Graceful Restart : Enabled
GR Helper Mode : Enabled
LSP Lifetime : 2400
LSP Wait : 120 sec (Max) 0 sec (Initial) 1 sec (Second)
LSP MTU Size : 9190 (Config) 9190 (Oper)
Adjacency Check : strict
L1 Auth Type : password
L2 Auth Type : md5
L1 CSNP-Authenticati* : Enabled
L1 HELLO-Authenticat* : Enabled
L1 PSNP-Authenticati* : Enabled
L1 Preference : 30
L2 Preference : 22
L1 Ext. Preference : 40
L2 Ext. Preference : 34
L1 Wide Metrics : Enabled
L2 Wide Metrics : Enabled
L1 LSDB Overload : Disabled
L2 LSDB Overload : Disabled
L1 LSPs : 1
L2 LSPs : 1
L1 Default Metric : 10
L2 Default Metric : 10
L1 IPv6 Def Metric : 10
L2 IPv6 Def Metric : 10
Last SPF : 10/01/2011 04:11:49
SPF Wait : 120 sec (Max) 1000 ms (Initial) 1000 ms (Second)
Export Policies : None
Multicast Import : None
Multi-topology : Disabled
Advertise-Passive-On* : Enabled
```

```

Suppress Default : Enabled
Default Route Tag : 1
Area Addresses : 49.0001
 : 47.1234.1234.1234.1234.1234.ffff
Ldp Sync Admin State : Down
LDP-over-RSVP : Enabled
RSVP-Shortcut : Enabled
Advertise-Tunnel-Link : Disabled
Export Limit : 0
Exp Lmt Log Percent : 0
Total Exp Routes(L1) : 0
Total Exp Routes(L2) : 0
IID TLV : Enabled
All-L1-MacAddr : 01:80:c2:00:00:14
All-L2-MacAddr : 01:80:c2:00:00:15
Loopfree-Alternate : Enabled
L1 LFA : Included
L2 LFA : Included

```

```

=====
* indicates that the corresponding row element may have been truncated.

```

```

Task 113366: IPFRR

```

```

*A:SRR>config>router>isis# show router isis status

```

```

=====
ISIS Status
=====
System Id : 1100.2000.1002
Admin State : Up
Ipv4 Routing : Enabled
Ipv6 Routing : Enabled, Native
Last Enabled : 07/25/2011 18:11:34
Level Capability : L1L2
Authentication Check : True
Authentication Type : None
CSNP-Authentication : Enabled
HELLO-Authentication : Enabled
PSNP-Authentication : Enabled
Traffic Engineering : Enabled
Graceful Restart : Disabled
GR Helper Mode : Disabled
LSP Lifetime : 350
LSP Wait : 5 sec (Max) 0 sec (Initial) 1 sec (Second)
LSP MTU Size : 1492 (Config) 1492 (Oper)
Adjacency Check : loose
L1 Auth Type : none
L2 Auth Type : none
L1 CSNP-Authenticati* : Enabled
L1 HELLO-Authenticat* : Enabled
L1 PSNP-Authenticati* : Enabled
L1 Preference : 15
L2 Preference : 18
L1 Ext. Preference : 160
L2 Ext. Preference : 165
L1 Wide Metrics : Enabled

```

## Show Commands

```
L2 Wide Metrics : Enabled
L1 LSDB Overload : Disabled
L2 LSDB Overload : Disabled
L1 LSPs : 86
L2 LSPs : 113
L1 Default Metric : 10
L2 Default Metric : 10
L1 IPv6 Def Metric : 10
L2 IPv6 Def Metric : 10
Last SPF : 07/26/2011 15:27:09
SPF Wait : 10 sec (Max) 1000 ms (Initial) 1000 ms (Second)
Export Policies : isis_from_ALL_to_0
Multicast Import : both
Multi-topology : Enabled
Advertise-Passive-On* : Disabled
Suppress Default : Disabled
Default Route Tag : None
Area Addresses : 49.0001
Ldp Sync Admin State : Up
LDP-over-RSVP : Enabled
RSVP-Shortcut : Disabled
Advertise-Tunnel-Link : Disabled
Export Limit : 0
Exp Lmt Log Percent : 0
Total Exp Routes(L1) : 0
Total Exp Routes(L2) : 0
IID TLV : Disabled
All-L1-MacAddr : 01:80:c2:00:00:14
All-L2-MacAddr : 01:80:c2:00:00:15
Loopfree-Alternate : Enabled
=====
* indicates that the corresponding row element may have been truncated.
*A:SRR>config>router>isis#
```

## summary-address

**Syntax** `summary-address [ip-address [/mask]]`

**Context** `show>router>isis`

**Description** Displays ISIS summary addresses.

**Output** **Router ISIS Summary Address Output** — The following table describes the ISIS summary address output fields.

| Label   | Description                                                           |
|---------|-----------------------------------------------------------------------|
| Address | The IP address.                                                       |
| Level   | Specifies the IS-IS level from which the prefix should be summarized. |

### Sample Output

```

A:ALA-48# show router isis summary-address
=====
ISIS Summary Address
=====
Address Level

1.0.0.0/8 L1
2.1.0.0/24 L1L2
3.1.2.3/32 L2

Summary Addresses : 3
=====
A:ALA-48#

```

## topology

**Syntax** `topology [ipv4-unicast | ipv6-unicast | mt mt-id-number] [detail]`

**Context** show>router>isis

**Description** This command shows IS-IS topology information.

**Parameters** **ipv4-unicast** — Displays IPv4 unicast parameters.

**ipv6-unicast** — Displays IPv6 unicast parameters.

**mt *mt-id-number*** — Displays multi-topology parameters.

**Values** 0, 2

**detail** — Displays detailed topology information.

**Output** **Router ISIS Topology Output** — The following table describes the ISIS topology output fields.

| Label     | Description                      |
|-----------|----------------------------------|
| Node      | Displays the IP address.         |
| Interface | Displays the interface name.     |
| Nexthop   | Displays the nexthop IP address. |

### Sample Output

```

*A:Dut-A# show router isis topology
=====
Topology Table
=====
Node Interface Nexthop

IS-IS IP paths (MT-ID 0), Level 1

```

## Show Commands

```
Dut-B.00 ip-3FFE::A0A:101 Dut-B
Dut-B.01 ip-3FFE::A0A:101 Dut-B
Dut-CA.00 ip-3FFE::A0A:101 Dut-B
Dut-CA.01 ip-3FFE::A0A:101 Dut-B
Dut-CA.02 ip-3FFE::A0A:101 Dut-B
Dut-CA.05 ip-3FFE::A0A:101 Dut-B
Dut-DA.00 ip-3FFE::A0A:101 Dut-B
Dut-DA.01 ip-3FFE::A0A:101 Dut-B
Dut-E.00 ip-3FFE::A0A:101 Dut-B
Dut-F.00 ies-1-3FFE::A0A:1501 Dut-F
Dut-F.01 ies-1-3FFE::A0A:1501 Dut-F
Dut-F.02 ies-1-3FFE::A0A:1501 Dut-F
```

-----  
IS-IS IPv6 paths (MT-ID 2), Level 1  
-----

```
Dut-B.00 ip-3FFE::A0A:101 Dut-B
Dut-B.01 ip-3FFE::A0A:101 Dut-B
Dut-CA.00 ip-3FFE::A0A:101 Dut-B
Dut-CA.01 ip-3FFE::A0A:101 Dut-B
Dut-CA.02 ip-3FFE::A0A:101 Dut-B
Dut-CA.05 ip-3FFE::A0A:101 Dut-B
Dut-DA.00 ip-3FFE::A0A:101 Dut-B
Dut-DA.01 ip-3FFE::A0A:101 Dut-B
Dut-E.00 ip-3FFE::A0A:101 Dut-B
Dut-F.00 ies-1-3FFE::A0A:1501 Dut-F
Dut-F.01 ies-1-3FFE::A0A:1501 Dut-F
Dut-F.02 ies-1-3FFE::A0A:1501 Dut-F
```

-----  
IS-IS IP paths (MT-ID 0), Level 2  
-----

```
Dut-B.00 ip-3FFE::A0A:101 Dut-B
Dut-B.01 ip-3FFE::A0A:101 Dut-B
Dut-CA.00 ip-3FFE::A0A:101 Dut-B
Dut-CA.01 ip-3FFE::A0A:101 Dut-B
Dut-CA.02 ip-3FFE::A0A:101 Dut-B
Dut-CA.05 ip-3FFE::A0A:101 Dut-B
Dut-DA.00 ip-3FFE::A0A:101 Dut-B
Dut-DA.01 ip-3FFE::A0A:101 Dut-B
Dut-E.00 ip-3FFE::A0A:101 Dut-B
Dut-F.00 ies-1-3FFE::A0A:1501 Dut-F
Dut-F.01 ies-1-3FFE::A0A:1501 Dut-F
Dut-F.02 ies-1-3FFE::A0A:1501 Dut-F
```

-----  
IS-IS IPv6 paths (MT-ID 2), Level 2  
-----

```
Dut-B.00 ip-3FFE::A0A:101 Dut-B
Dut-B.01 ip-3FFE::A0A:101 Dut-B
Dut-CA.00 ip-3FFE::A0A:101 Dut-B
Dut-CA.01 ip-3FFE::A0A:101 Dut-B
Dut-CA.02 ip-3FFE::A0A:101 Dut-B
Dut-CA.05 ip-3FFE::A0A:101 Dut-B
Dut-DA.00 ip-3FFE::A0A:101 Dut-B
Dut-DA.01 ip-3FFE::A0A:101 Dut-B
Dut-E.00 ip-3FFE::A0A:101 Dut-B
Dut-F.00 ies-1-3FFE::A0A:1501 Dut-F
Dut-F.01 ies-1-3FFE::A0A:1501 Dut-F
Dut-F.02 ies-1-3FFE::A0A:1501 Dut-F
```

=====  
\*A:Dut-A#

---

## Clear Commands

### isis

**Syntax** `isis [isis-instance]`

**Context** `clear>router>isis`

**Description** This command enables the context to clear and reset ISIS protocol entities.

**Parameters** *isis-instance* — Specifies the IS-IS instance.

**Values** 1 — 31

### adjacency

**Syntax** `adjacency [system-id]`

**Context** `clear>router>isis`

**Description** This command clears and resets the entries from the IS-IS adjacency database.

**Parameters** *system-id* — When the system ID is entered, only the specified entries are removed from the IS-IS adjacency database.

### database

**Syntax** `database [system-id]`

**Context** `clear>router>isis`

**Description** This command removes the entries from the IS-IS link-state database which contains information about PDUs.

**Parameters** *system-id* — When the system ID is entered, only the specified entries are removed from the IS-IS link-state database.

## Clear Commands

### export

**Syntax** **export**

**Context** clear>router>isis

**Description** This command re-evaluates route policies participating in the export mechanism, either as importers or exporters of routes.

### spf-log

**Syntax** **spf-log**

**Context** clear>router>isis

**Description** This command clears the SPF log.

### statistics

**Syntax** **statistics**

**Context** clear>router>isis

**Description** This command clears and resets IS-IS statistics.



---

## Debug Commands

### adjacency

**Syntax** [no] adjacency [*ip-int-name* | *ip-address* | *nbr-system-id*]

**Context** debug>router>isis

**Description** This command enables debugging for IS-IS adjacency.  
The **no** form of the command disables debugging.

### cspf

**Syntax** [no] cspf

**Context** debug>router>isis

**Description** This command enables debugging for IS-IS cspf.  
The **no** form of the command disables debugging.

### graceful-restart

**Syntax** [no] graceful-restart

**Context** debug>router>isis

**Description** This command enables debugging for IS-IS graceful-restart.  
The **no** form of the command disables debugging.

### interface

**Syntax** interface [*ip-int-name* | *ip-address*]  
**no interface**

**Context** debug>router>isis

**Description** This command enables debugging for IS-IS interface.  
The **no** form of the command disables debugging.

## Debug Commands

### leak

**Syntax**    **leak** [*ip-address*]  
**no leak**

**Context**    debug>router>isis

**Description**    This command enables debugging for IS-IS leaks.  
The **no** form of the command disables debugging.

### lsdb

**Syntax**    [**no**] **lsdb** [*level-number*] [*system-id* | *lsp-id*]

**Context**    debug>router>isis

**Description**    This command enables debugging for Link State DataBase (LSDB).  
The **no** form of the command disables debugging.

### misc

**Syntax**    [**no**] **misc**

**Context**    debug>router>isis

**Description**    This command enables debugging for IS-IS misc.  
The **no** form of the command disables debugging.

### packet

**Syntax**    **packet** [*packet-type*] [*ip-int-name* | *ip-address*] [detail]

**Context**    debug>router>isis

**Description**    This command enables debugging for IS-IS packets.  
The **no** form of the command disables debugging.

## rtm

**Syntax**     **rtm** [*ip-address*]  
              **no rtm**

**Context**     debug>router>isis

**Description**   This command enables debugging for IS-IS route table manager (RTM).  
                  The **no** form of the command disables debugging.

## spf

**Syntax**     [**no**] **spf** [*level-number*] [*system-id*]

**Context**     debug>router>isis

**Description**   This command enables debugging for IS-IS SFP.  
                  The **no** form of the command disables debugging.



---

## In This Chapter

This chapter provides information to configure BGP.

Topics in this chapter include:

- [BGP Overview on page 566](#)
  - [BGP Communication on page 566](#)
  - [Group Configuration and Peers on page 568](#)
  - [Hierarchical Levels on page 569](#)
  - [Route Reflection on page 569](#)
  - [BGP Route Tunnel on page 573](#)
  - [RSVP-TE LSP Shortcut for BGP Next-Hop Resolution on page 575](#)
  - [BGP Confederations on page 577](#)
  - [BGP Add-Path on page 584](#)
  - [Command Interactions and Dependencies on page 593](#)
    - [Changing the Autonomous System Number on page 593](#)
    - [Changing the Router ID at the Configuration Level on page 594](#)
    - [Changing the Local AS Number on page 594](#)
    - [Hold Time and Keep Alive Timer Dependencies on page 595](#)
    - [Import and Export Route Policies on page 596](#)
    - [Route Damping and Route Policies on page 596](#)
    - [AS Override on page 596](#)
    - [TTL Security for BGP and LDP on page 601](#)
- [BGP Configuration Process Overview on page 602](#)
- [Configuration Notes on page 603](#)

## BGP Overview

Border Gateway Protocol (BGP) is an inter-autonomous system routing protocol. An autonomous system is a network or a group of routers logically organized and controlled by a common network administration. BGP enables routers to exchange network reachability information, including information about other ASs that traffic must traverse to reach other routers in other ASs. In order to implement BGP in the base router instance, the AS number must be specified in the `config>router` context. A 7750 SR OS BGP configuration must contain at least one group and include information about at least one neighbor (peer).

AS paths are the routes to each destination. Other attributes, such as the path's origin, the multiple exit discriminator (MED), the local preference and communities included with the route are called path attributes. When BGP interprets routing and topology information, loops can be detected and eliminated. Route preference for routes learned from the configured peer(s) can be enabled among groups of routes to enforce administrative preferences and routing policy decisions.

---

## BGP Communication

There are three types of BGP peers, internal BGP (IBGP), confederation external BGP (confed-EBGP), and external BGP (EBGP) ([Figure 22](#)).

- IBGP is used to communicate with peers in the same autonomous system. Routes received from an IBGP peer in the same autonomous system are not advertised to other IBGP peers (unless the router is a route reflector) but can be advertised to an EBGP peer.
- Confed-EBGP is used to communicate with peers in a different member-AS of the same BGP confederation. More details are provided in the section on BGP confederations.
- EBGP is used to communicate with peers in different autonomous systems. Routes received from an router in a different AS can be advertised to both EBGP and IBGP peers.

Autonomous systems share routing information, such as routes to each destination and information about the route or AS path, with other ASs using BGP. Routing tables contain lists of known routers, reachable addresses, and associated path cost metrics to each router. BGP uses the information and path attributes to compile a network topology.

---

## Message Types

Four message types are used by BGP to negotiate parameters, exchange routing information and indicate errors. They are:

- Open Message — After a transport protocol connection is established, the first message sent by each side is an Open message. If the Open message is acceptable, a Keepalive

message confirming the Open is sent back. Once the Open is confirmed, Update, Keepalive, and Notification messages can be exchanged.

Open messages consist of the BGP header and the following fields:

- Version — The current BGP version number is 4.
- Local AS number — For the base router BGP instance, this is usually the autonomous system number configured in the `config>router` context, however, it can be overridden on a per-session basis using the **local-as** command.
- Hold time — The proposed maximum time BGP will wait between successive messages (either keep alive or update) from its peer, before closing the connection. The actual hold time is the minimum of the configured hold-time for the session and the hold-time in the peer's Open message. If this minimum is below a configured threshold (min hold time), the connection attempt is rejected.
- BGP identifier — The router ID of the BGP speaker. In Open messages sent by 7x50, the BGP identifier comes from the **router-id** configured under **config>router>bgp**; if that is not configured then the **router-id** configured under **config>router** is used; if that too is not configured then the system interface IP address is used as the router ID. Note that a change of the router ID in the **config>router>bgp** context causes all BGP sessions to be reset immediately while other changes resulting in a new BGP identifier only take effect after BGP is shutdown and re-enabled.
- Update Message — Update messages are used to transfer routing information between BGP peers. The information contained in the message can be used to construct a graph describing the relationships of the various autonomous systems. By applying rules, routing information loops and some other anomalies can be detected and removed from the inter-AS routing,

The update messages consist of a BGP header and the following fields:

- Unfeasible routes length — The length of the withdrawn routed field, which lists the routes being withdrawn from service because they are considered unreachable.
- Withdrawn routes — The associated IP address prefixes for the routes withdrawn from service.
- Total path attribute length — The total length of the path attributes field that provides the attributes for a possible route to a destination.
- Path attributes — The path attributes presented in variable length TLV format.
- Network layer reachability information (NLRI) — IPv4 address prefixes of that are advertised as being reachable over the associated path.
- Keepalive Message — Keepalive messages, consisting of only a 19 octet message header, are exchanged between peers frequently so hold timers do not expire. The keepalive messages are one method of determining a connectivity failure to the peer.
- Notification — A Notification message is sent when an error condition is detected. The peering session is terminated and the BGP connection (TCP connection) is closed immediately after sending it.

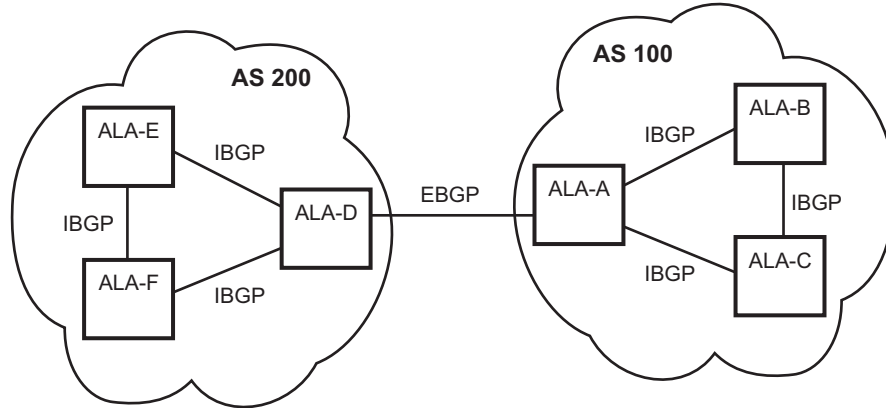

OSRG053

Figure 22: BGP Configuration

---

## Group Configuration and Peers

To enable BGP routing, participating routers must have BGP enabled and be assigned to an autonomous system and the neighbor (peer) relationships must be specified. A router typically belongs to only one AS. TCP connections must be established in order for neighbors to exchange routing information and updates. Neighbors exchange BGP open messages that includes information such as AS numbers, BGP versions, router IDs, and hold-time values. Keepalive messages determine if a connection is established and operational. The hold-time value specifies the maximum time BGP will wait between successive messages (either keep alive or update) from its peer, before closing the connection.

In BGP, peers are arranged into groups. A group must contain at least one neighbor. A neighbor must belong to a group. Groups allow multiple peers to share similar configuration attributes.

Although neighbors do not have to belong to the same AS, they must be able to communicate with each other. If TCP connections are not established between two neighbors, the BGP peering will not be established and updates will not be exchanged.

Peer relationships are defined by configuring the IP address of the routers that are peers of the local BGP system. When neighbor and peer relationships are configured, the BGP peers exchange Update messages to advertise network reachability information.



## Hierarchical Levels

BGP parameters are initially applied on the global level. These parameters are inherited by the group and neighbor (peer) levels. Parameters can be modified and overridden on a level-specific basis. BGP command hierarchy consists of three levels:

- Global level
- Group level
- Neighbor level

Many of the hierarchical BGP commands can be modified on different levels. The most specific value is used. That is, a BGP group-specific command takes precedence over a global BGP command. A neighbor-specific statement takes precedence over a global BGP and group-specific command; for example, if you modify a BGP neighbor-level command default, the new value takes precedence over group- and global- level settings.

NOTE: Careful planning is essential to implement commands that can affect the behavior of global, group, and neighbor-levels. Because the BGP commands are hierarchical, analyze the values that can disable features on the global or group levels that must be enabled at the neighbor level. For example, if you enable the damping command on the global level but want it disabled only for a specific neighbor (not for all neighbors within the group), you cannot configure a `double-no` command (`no no damping`) to enable the feature.

---

## Route Reflection

In a standard BGP configuration, all BGP speakers within an AS, must have full BGP mesh to ensure that all externally learned routes are redistributed through the entire AS. IBGP speakers do not re-advertise routes learned from one IBGP peer to another IBGP peer. If a network grows, scaling issues could emerge because of the full mesh configuration requirement. Instead of peering with all other IBGP routers in the network, each IBGP router only peers with a router configured as a route reflector.

Route reflection circumvents the full mesh requirement but maintains the full distribution of external routing information within an AS. Route reflection is effective in large networks because it is manageable, scalable, and easy to implement. Route reflection is implemented in autonomous systems with a large internal BGP mesh to reduce the number of IBGP sessions required within an AS.

A large AS can be sub-divided into one or more *clusters*. Each cluster contains at least one route reflector which is responsible for redistributing route updates to all clients. Route reflector clients do not need to maintain a full peering mesh between each other. They only require a peering to the

route reflector(s) in their cluster. The route reflectors must maintain a full peering mesh between all non-clients within the AS.

Each route reflector must be assigned a cluster ID and specify which neighbors are clients and which are non-clients to determine which neighbors should receive reflected routes and which should be treated as a standard IBGP peer. Additional configuration is not required for the route reflector besides the typical BGP neighbor parameters.

Figure 23 displays a simple full-mesh configuration with several BGP routers. When SR-A receives a route from SR-1 (an external neighbor), it must advertise route information to all of its IBGP peers (SR-B, SR-C, SR-D, etc). To prevent loops, IBGP learned routes are not re-advertised to other IBGP peers.

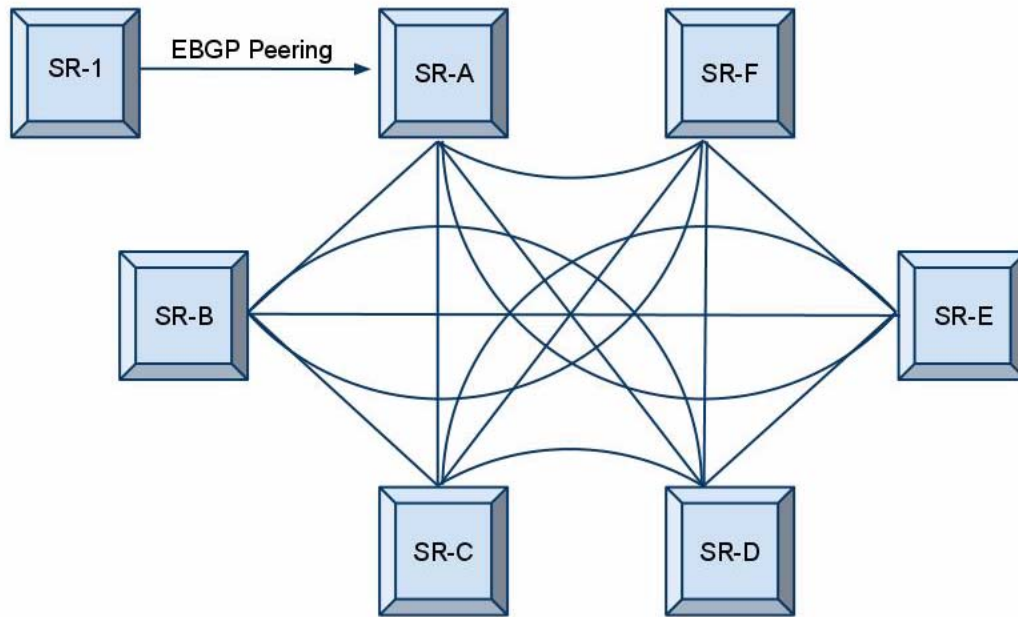
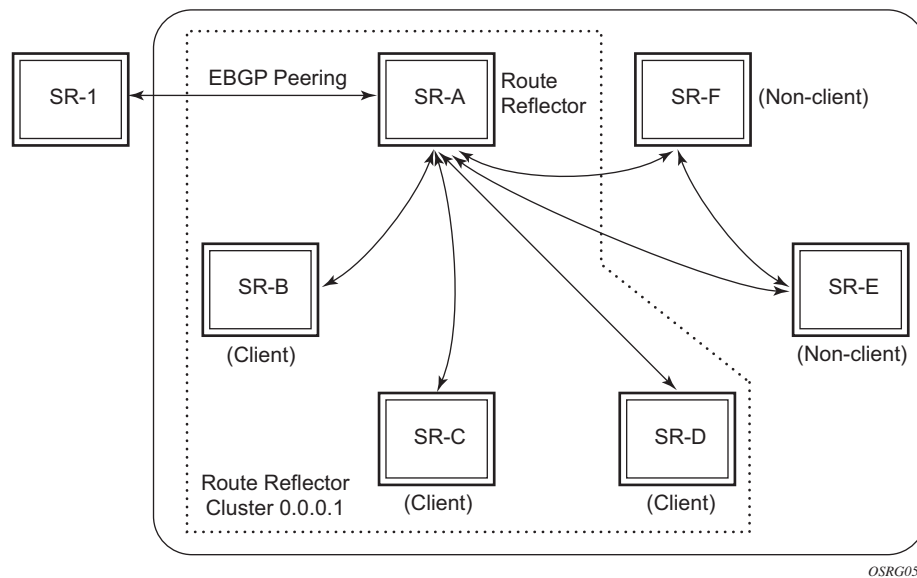

Figure 23: Fully Meshed BGP Configuration

When route reflectors are configured, the routers within a cluster do not need to be fully meshed. [Figure 23](#) depicts a fully meshed network and [Figure 24](#) depicts the same network but with route reflectors configured to minimize the IBGP mesh between SR-A, SR-B, SR-C, and SR-D. SR-A, configured as the route reflector, is responsible for redistributing route updates to clients SR-B, SR-C, and SR-D. IBGP peering between SR-B, SR-C and SR-D is not necessary because even IBGP learned routes are reflected to the route reflector's clients.

In [Figure 24](#), SR-E and SR-F are shown as non-clients of the route reflector. As a result, a full mesh of IBGP peering must be maintained between, SR-A, SR-E and SR-F.



**Figure 24: BGP Configuration with Route Reflectors**

When a route reflector receives an advertised route, it selects the best path. If the best path was received from an EBGP peer then it is typically advertised, with next hop unchanged, to all clients and non-client peers of the route reflector. If the best path was received from a non-client peer then it is advertised to all clients of the route reflector. If the best path was received from a client then it is advertised to all clients and non-client peers.

## Fast External Failover

Fast external failover on a group and neighbor basis is supported. For eBGP neighbors, this feature controls whether the router should drop an eBGP session immediately upon an interface-down event, or whether the BGP session should be kept up until the hold-time expires.

When fast external failover is disabled, the eBGP session stays up until the hold-time expires or the interface comes back up. If the BGP routes become unreachable as a result of the down IP interface, BGP withdraws the associated routes towards other peers.

---

## Sending of BGP Communities

The capability to explicitly enable or disable the sending of the BGP community attribute to BGP neighbors, other than through the use of policy statements, is supported.

This feature allows an administrator to enable or disable the sending of BGP communities to an associated peer. This feature overrides communities that are already associated with a given route or that may have been added via an export route policy. In other words, even if the export policies leave BGP communities attached to a given route, when the disable-communities feature is enabled, no BGP communities are advertised to the associated BGP peers.

## BGP Route Tunnel

BGP-tunnel defines a method to distribute MPLS labels associated with a route advertisement. BGP speakers exchanging routes piggyback a label based on Multi-protocol Extensions Attribute. The label is encoded in the NLRI field and SAFI is used to indicate that the NLRI contains a label. Labeled route update is only exchanged between BGP speakers supporting AFI/SAFI for MPLS Label Capability.

BGP speakers not adjacent to each other may choose LDP or RSVP-TE tunnels to reach the next-hop of a BGP labeled route next-hop. Client applications using BGP tunnels must push two labels (BGP label and LDP/RSVP label) on top of the existing label stack (which will typically include one or more service-specific labels) in order to reach the BGP next-hop. The next-hop BGP node can either resolve its own local LDP or RSVP LSPs to reach its next-hop for BGP tunnel, or it may terminate locally.

If BGP speaker nodes are adjacent to each other (for example, ASBRs running EBGP session) and have exchange labeled routes, then only the BGP route label is used to forward traffic towards the next-hop node. If the BGP route tunnel transits through multiple AS, then each AS segment would have two labels. The last BGP segment ASBR may select to have either one (LDP/RSVP) or two (BGP + LDP/RSVP) labels to reach far-end.

---

## ECMP and BGP Route Tunnels

ECMP is only available for BGP route tunnels and not the transport LSP that is used to resolve BGP next-hop. If multiple LSP next-hops are available, then only the first next-hop is used and the rest ignored.

---

## Layer 2 Services and BGP Route Tunnel

MPLS transport tunnel per VPLS/VLL instance is enabled by an explicit MPLS-SDP configuration for each far-end PE. For BGP-AD based VPLS, SDP must be manually configured to reach the far-end.

---

## BGP Route Tunnel SDP Binding

BGP route tunnel based SDP binding is allowed for VPLS and VLL services. Any service using BGP SDP must presume a two label stack to compute SDP MTU.

## **BGP Route Tunnel Based BGP-AD Support**

LDP is the only supported transport method with pw-template.

---

### **BGP Route Tunnel with multi-hop eBGP session**

Either RSVP-TE or LDP LSP can be used to resolve the next-hop between two ASBR nodes. The "transport-tunnel" CLI command can be used to select the specific transport LSP method. The "mpls" option under "transport-tunnel" will enable the option to allow either RSVP-TE LSP or LDP LSP. Availability of RSVP-TE LSP is checked at higher priority. If RSVP-TE LSP is not available then LDP LSP is selected.

## RSVP-TE LSP Shortcut for BGP Next-Hop Resolution

RSVP-TE shortcut for BGP next-hop resolution is enabled by entering the **config>router>bgp>igp-shortcut rsvp** command at the BGP protocol level.

This command instructs BGP to search for the best metric RSVP LSP to the /32 address of the BGP next-hop. This address can correspond to the system interface or to another loopback used by the BGP instance on the remote node as its router-id. The LSP metric is provided by MPLS in the tunnel table.

In order to provide fallback from RSVP-TE LSP shortcut to an LDP LSP shortcut and then to the IGP next-hop, the above new command is extended to support the following options:

```
config>router>bgp>igp-shortcut [ldp | rsvp-te | mpls][disallow-igp]
```

The **ldp** option instructs BGP to search for an LDP LSP with a FEC prefix corresponding to the /32 address of the BGP next-hop. This deprecates the existing `ldp-shortcut` command under BGP. Support for the older command will be provided over a number of releases to allow old config files to execute.

The **rsvp-te** option instructs BGP to search for the best metric RSVP LSP to the /32 address of the BGP next-hop. This address can correspond to the system interface or to another loopback used by the BGP instance on the remote node as its router-id. The LSP metric is provided by MPLS in the tunnel table.

The **mpls** option instructs BGP to first attempt to resolve the BGP next-hop to an RSVP LSP. If no RSVP LSP exists or if the existing ones are down, BGP will automatically search for the LDP LSP with a FEC prefix corresponding to the same /32 prefix in the tunnel table and will resolve the BGP next-hop to it.

The **disallow-igp** option also deprecates the existing one under BGP. It continues to work transparently regardless of which type of LSP shortcut, RSVP or LDP, is being used by BGP at any given time. When this option is enabled and if an LSP shortcut of the configured type is not available, the IGP next-hop route will not be used for the BGP next-hop resolution.

---

## Core IPv4 Prefix Resolution

The recursive lookup of an IPv4 prefix in RTM will result first in the BGP next-hop determination for the packet's prefix and then the IGP next-hop resolution for the BGP next-hop prefix. When the **igp-shortcut rsvp-te** option is enabled in BGP, the IGP resolution for the BGP next-hop will provide the best metric RSVP LSP to the BGP next-hop address as the next-hop shortcut. This RSVP shortcut next-hop is installed as a route in the ingress IOM tunnel table.

When an IPv4 packet for this prefix is received on an ingress network interface, a subscriber IES interface, or a regular IES interface, the ingress IOM lookup of the packet will result in sending the packet labeled with the label stack corresponding to the NHLFE of the RSVP LSP.

The failure of a used RSVP LSP shortcut triggers a new resolution which will result in installing a new route in the ingress IOM tunnel table over another RSVP LSP shortcut if available, or an LDP LSP if the **igp-shortcut mpls** option is enabled, or a regular IP next-hop if the **disallow-igp** option is disabled.

---

### Handling of Control Packets

All control plane packets that require an RTM lookup and whose destination is reachable over a BGP next-hop resolved to an RSVP shortcut will be forwarded over the shortcut. This effectively excludes the vast majority of control packets which have destinations within an autonomous system. The exceptions are for locally generated or in transit ICMP ping and trace route messages for destinations outside of the local autonomous system.



## BGP Confederations

In a standard BGP configuration, all BGP speakers, within an autonomous system (AS), have a full mesh of BGP peerings to ensure all externally learned routes are redistributed through out the entire AS. This is due to the fact that IBGP speakers do not re-advertise routes learned from one IBGP peer to another IBGP peer. However, as a network grows, scaling issues emerge due to the full mesh requirement. The BGP confederation feature is one method to alleviate the full mesh requirement while still maintaining the full distribution of external routing information within an AS; another method that has already been discussed is to use route reflectors.

To form BGP confederations, an AS is logically divided into smaller groupings called sub-confederations. Each sub-confederation must maintain a full mesh of IBGP peerings between all its members (or use route reflection).

The structure of the BGP confederation is not visible to outside autonomous systems. All confederation specific path attributes are stripped from route updates before they are advertised to external BGP peers.

Sub-confederation ASs have EBGP-type peers to other sub-confederation ASs within the confederation. They exchange routing updates as if they were using IBGP. Parameter values such as next hop, metric, and local preference settings are preserved. The confederation appears and behaves like a single AS.

Confederations have the following characteristics:

- A large AS can be sub-divided into smaller ASs (sub-confederations).
- Inside each smaller AS, routing *within* each sub-confederation is accomplished via IBGP.
- Confed-EBGP is used to communicate *between* sub-confederations.
- BGP speakers within a sub-confederation must be fully meshed (or use route reflection).
- Each sub-confederation (member) of the confederation has a different AS number. The AS numbers used are typically in the private AS range of 64512 — 65535.

To configure a 7x50 router to belong to a confederation, the confederation number and the sub-AS numbers that are members of the confederation must be configured using the confederation command in the **config>router** context. The autonomous system of the router, as configured in the **config>router** context, should be one of the sub-AS members of the confederation.



## BGP Decision Process

When a BGP router has multiple routes to a destination in its RIB-IN the BGP decision process is responsible for deciding which one is the best. Whenever a new route is received (for a prefix) the BGP decision process compares this route to the current best path for that prefix by making a series of comparisons. It determines from this process whether the new path should become the new best path or not. This is the sequence of comparisons performed by 7x50:

1. Select the route with the highest route preference.
2. Select the route with the highest Local Preference (LOCAL\_PREF).
3. Select the route with the least number of ASNs in its AS Path (unless as-path-ignore is configured). Note that an AS\_SET counts as one ASN.
4. Select the route with the lowest Origin.
5. Select the route with the lowest MED if one the following applies:
  - a. Both routes have the MED attribute and were advertised by the same neighbor AS (leftmost [non-confed] AS in AS\_PATH).
  - b. Both routes were advertised by different neighbor AS but always-compare-med without the strict-as option is configured.
  - c. One or both routes do not have the MED but always-compare-med is configured and indicates the MED value to assume for routes that do not have the attribute.
6. Select the route learned from an EBGP peer over the route learned from an IBGP peer.
7. Select the route with the lowest distance between the calculating router and the BGP NEXT\_HOP of the route (unless ignore-nh-metric is configured). If the BGP NEXT\_HOP is resolved by an RSVP-TE tunnel then the configured tunnel metric is used in place of the actual IGP path cost.
8. Select the route with the lowest Originator ID or received from the peer with the lowest BGP Identifier (unless ignore-router-id is configured, and the routes being compared are EBGP routes).
9. Select the route with the shortest Cluster List. An empty cluster list is considered to have a length of 0.
10. Select the route received from the lowest peer IP address.

---

### Option to Ignore Router ID

RFC 5004 describes that in some cases the comparison of router ID in step 8 results in an unnecessary best path transition that achieves nothing except additional churn and instability. To comply with RFC 5004, a configuration option to skip steps 8-10 when comparing two paths learned from different EBGP neighbors is supported.

To support RFC 5004, the **ignore-router-id** command is available in the `config>router>bgp>best-path-selection` and `config>service>vprn>bgp>best-path-selection` configuration contexts. When this command is present and the current best path to a destination was learned from EBGP peer X with BGP identifier x and a new path is received from EBGP peer Y with BGP identifier y the best path remains unchanged if the new path is equivalent to the current best path up to the BGP identifier comparison and y is less than x.

**Note:** If either the current best path or the new path is from a confed-EBGP peer, or the EBGP-learned paths have been received from the same neighbor (same BGP identifier) , then steps 8-10 continue to apply.

## always-compare-med Command

By default, the Multi-Exit Discriminator (MED) path attribute is used in the decision process only if both routes in the comparison have the attribute and come from the same neighbor AS. However, these rules can be modified using the **always-compare-med** command.

The **always-compare-med** command without the **strict-as** keyword allows BGP paths to be compared even if they have different neighbor autonomous systems (in this case, if neither **zero** or **infinity** is part of the command, the comparison requires both paths to have a MED attribute otherwise, **zero** or **infinity** specifies the MED value that should be inferred for paths without the attribute). When the **strict-as** keyword is present, MED is only compared between paths from the same neighbor AS and in this case **zero** or **infinity** is mandatory and tells BGP how to interpret paths without a MED attribute.

Table 14 shows how the MED comparison of two paths is influenced by different forms of the **always-compare-med** command.

**Table 14: MED Comparison with always-compare-med**

| Command                 | MED comparison step in decision process                                                                                                                                                |
|-------------------------|----------------------------------------------------------------------------------------------------------------------------------------------------------------------------------------|
| no always-compare-med   | Only compare the MED of two paths if they come from the same neighbor-AS and both paths have the MED attribute. Otherwise skip the step.                                               |
| always-compare-med      | Only compare the MED of two paths (whether or not they are from the same neighbor-AS) if they both have the MED attribute. Otherwise skip the step.                                    |
| always-compare-med zero | Always compare the MED of two paths, even if they are from different neighbor-AS. If one or both paths do not have a MED attribute, consider the MED to be zero (best possible value). |

**Table 14: MED Comparison with always-compare-med (Continued)**

| Command                               | MED comparison step in decision process                                                                                                                                                 |
|---------------------------------------|-----------------------------------------------------------------------------------------------------------------------------------------------------------------------------------------|
| always-compare-med infinity           | Always compare MED of two paths, even if they are from different neighbor-AS. If one or both paths do not have a MED attribute, consider the MED to be infinite (worse possible value). |
| always-compare-med strict-as zero     | Only compare the MED of two paths if they come from the same neighbor-AS. If one or both paths do not have a MED attribute, consider the MED to be zero (best possible value).          |
| always-compare-med strict-as infinity | Only compare the MED of two paths if they come from the same neighbor-AS. If one or both paths do not have a MED attribute, consider the MED to be infinite (worse possible value).     |

---

## Option to Ignore Next-Hop Metric

The **ignore-nh-metric** command allows the step comparing the distance to the BGP next-hop to be skipped. When this command is present in the **config>service>vprn** context, it applies to the comparison of two imported BGP-VPN routes. When this command is present in the **config>router>bgp** context, it applies to the comparison of any two BGP routes received by that instance. And when this command is present in the **config>service>vprn>bgp** context, it applies to the comparison of two BGP routes learned from VPRN BGP peers (that is, CE peers). In all cases, this option is useful when there are multiple paths for a prefix that are the same in the IGP cost comparison step of the BGP decision process, and the network administrator wants all of them to be used for forwarding (BGP multipath).



## Best External

Best-external is a BGP enhancement that allows a BGP speaker to advertise to its IBGP peers its best “external” route for a prefix/NLRI even when its best overall route for the prefix/NLRI is an “internal” route. This is not possible in a “normal” BGP configuration because the base BGP specification prevents a BGP speaker from advertising a non-best route for a destination.

In certain topologies, best-external can improve convergence times, reduce route oscillation, and allow better loadsharing. This is achieved because routers internal to the AS have knowledge of more exit paths from the AS. Enabling Add-paths on border routers of the AS can achieve a similar result, but Add-paths introduces NLRI format changes that must be supported by BGP peers of the border router, and therefore has more interoperability constraints than best-external (which requires no messaging changes).

Enabling the best-external feature is supported only at the **config>router>bgp** level. This feature can be enabled/disabled on a per address family basis, with IPv4 and IPv6 as the only options supported initially. Enabling best-external for IPv4 causes the new advertisement rules to apply to both regular IPv4 unicast routes as well as labeled-IPv4 (SAFI4) routes. Similarly, enabling best-external for IPv6 causes the new advertisement rules to apply to both regular IPv6 unicast routes as well as labeled-IPv6 (SAFI4) routes.

The **advertise-external** command cannot be applied to a route reflector unless client-to-client reflection is disabled (disable-client-reflect in the CLI).

---

## Advertisement Rules with Best External

The advertisement rules when **advertise-external** is enabled can be summarized as follows:

1. If a router has **advertise-external** enabled and its best overall route is a route from an IBGP peer then this best route should be advertised to EBG and confed-EBGP peers, AND the “best external” route should be advertised to IBGP peers. The “best external” route is the one found by running the BGP path selection algorithm on all RIB-IN paths except for those learned from the IBGP peers.
2. If a router has **advertise-external** enabled and its best overall route is a route from an EBG peer then this best route should be advertised to EBG, confed-EBGP, and IBGP peers.
3. If a router has **advertise-external** enabled and its best overall route is a route from a confed-EBGP peer in member AS X then this best route should be advertised to EBG, IBGP peers and confed-EBGP peers in a member AS  $\neq$  X AND the “best internal” route should be advertised to confed-EBGP peers in member AS X. The “best internal” route is the one found by running the BGP path selection algorithm on all RIB-IN paths except for those learned from member AS X.

## BGP Add-Path

Add-paths is a BGP enhancement that allows a BGP router to advertise multiple distinct paths for the same prefix/NLRI. This provides a number of potential benefits, including reduced routing churn, faster convergence, and better loadsharing.

In order for router A to receive multiple paths per NLRI from peer B, for a particular address family, the BGP capabilities advertisement during session setup indicate that peer B wants to send multiple paths for this address family and router A is willing to receive multiple paths for the address family. Refer to draft-ietf-idr-add-paths-04.txt for details of the add-paths capabilities advertisement.

When the add-paths receive capability for an address family that has been negotiated with a peer, all advertisements and withdrawals of NLRI within that address family by that peer includes a path identifier, as described in draft-ietf-idr-add-paths-04.txt.

The path identifiers have no significance to the receiving peer. If the combination of NLRI and path identifier in an advertisement from a peer is unique (does not match an existing route in the RIB-IN from that peer) then the route is added to the RIB-IN. If the combination of NLRI and path identifier in a received advertisement is the same as an existing route in the RIB-IN from the peer then the new route replaces the existing one. If the combination of NLRI and path identifier in a received withdrawal matches an existing route in the RIB-IN from the peer then that route is removed from the RIB-IN. An UPDATE message carrying an IPv4 NLRI with a path identifier is shown in [Figure 25](#).

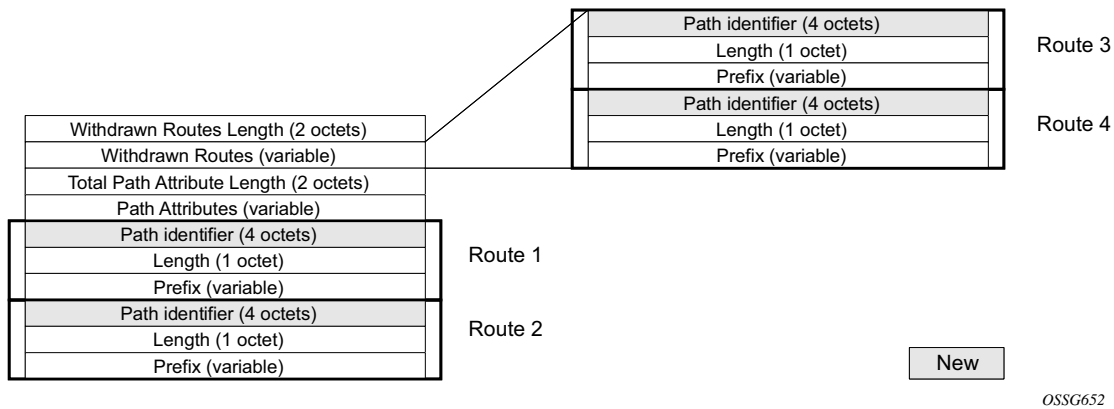

**Figure 25: BGP Update Message with Path Identifier for IPv4 NLRI**

Add-paths are only supported by the base router BGP instance and the EBGP and IBGP sessions it forms with other add-paths capable peers. The ability to send and receive multiple paths per prefix from to and an add-paths peer is configurable per family, with the supported families being:



- IPv4 (including labeled IPv4 routes)
- VPN-IPv4
- IPv6 (including labeled IPv6 routes)
- VPN-IPv6

## Sending Multiple Paths per Prefix to Add-Paths Peers

---

### Path Selection Mode and Parameters

The RIB-IN may have multiple paths for a prefix D. The path selection mode refers to the algorithm used to decide which of these paths to advertise to an add-paths peer. In the current implementation, SR supports only one path selection algorithm –essentially the Add-N algorithm described in draft-ietf-idr-add-paths-guidelines-00.txt, *Best Practices for Advertisement of Multiple Paths in BGP*. The Add-N algorithm implemented in SROS selects, as candidates for advertisement, the N best overall paths for each prefix, regardless of path type (internal vs. external), degree of difference between the paths or use in forwarding. If this set of N best overall paths includes multiple paths with the same BGP NEXT\_HOP only the best route with a particular NEXT\_HOP is advertised and the others are suppressed.

In the SROS implementation N is configurable, per address-family, at the BGP instance, group and neighbor levels; N has a minimum value of 1 and a maximum value of 16. For peer P belonging to group G the path selection parameters are based on the neighbor configuration for P else the group configuration for G else the BGP instance configuration.

When add-path is enabled for the VPN-IPv4 (or VPN-IPv6) address family in the base router BGP context only VPN-IP routes in the base router BGP RIB-IN are considered for advertisement to Add-Path peers, if a VPRN's best route to a destination is a bgp-vpn route imported from the base router and it's next-best route is a CE-learned BGP route that would be accepted by the VPRN's VRF export policy this next-best route is not advertised, regardless of the base router's Add-Path configuration.

---

### Routing Policy

BGP and VRF export policies are applied after path selection is performed. If add-paths is configured to send up to N paths to peer P and an export policy prevents X of the N best paths for prefix D from being advertised to P then only the remaining N-X best paths are sent.

---

### BGP Route Advertisement Rules

Add-paths allows non-best paths to be advertised to a peer but it still complies with basic BGP advertisement rules such as the IBGP split horizon rule: a route learned from an IBGP neighbor cannot be re-advertised to another IBGP neighbor unless the router is configured as a route reflector.

If add-paths is configured to send up to N paths to peer P and X of the N best paths for D cannot be advertised to P due to route advertisement rules then only the remaining N-X routes are advertised.

## BGP Fast Reroute

BGP fast reroute is a feature that brings together indirection techniques in the forwarding plane and pre-computation of BGP backup paths in the control plane to support fast reroute of BGP traffic around unreachable/failed next-hops. BGP fast reroute is supported for IPv4, IPv6, 6PE, VPN-IPv4 and VPN-IPv6 VPN routes. The supported scenarios are outlined in [Table 15](#).

**Table 15: BGP Fast Reroute Scenarios**

| Ingress packet | Context     | Primary route                                                                                                        | Backup route                                                                                                         | Supported | Comments      |
|----------------|-------------|----------------------------------------------------------------------------------------------------------------------|----------------------------------------------------------------------------------------------------------------------|-----------|---------------|
| IPv4           | GRT or VPRN | IPv4 route with IPv4 next-hop A (resolved by IPv4 route1)                                                            | IPv4 route with IPv4 next-hop B (resolved by IPv4 route2)                                                            | 9.0R4     |               |
| IPv4           | GRT         | IPv4 route with IPv4 next-hop A (resolved by tunnel1, which can be any of the following types: ldp, ldp/rsvp, rsvp). | IPv4 route with IPv4 next-hop B (resolved by tunnel2, which can be any of the following types: ldp, ldp/rsvp, rsvp). | 9.0R4     | BGP shortcuts |
| IPv4           | GRT         | IPv4 route with IPv4 next-hop A (resolved by IPv4 route1)                                                            | IPv4 route with IPv4 next-hop B (resolved by tunnel2, which can be any of the following types: ldp, ldp/rsvp, rsvp). | 9.0R4     |               |
| IPv6           | GRT or VPRN | IPv6 route with IPv6 next-hop A (resolved by IPv6 route1)                                                            | IPv6 route with IPv6 next-hop B (resolved by IPv6 route2)                                                            | 9.0R4     |               |
| IPv6           | GRT         | 3IPv6 route with IPv4 next-hop A (resolved by Iv4 route1)                                                            | IPv6 route with IPv4 next-hop B (resolved by IPv4 route2)                                                            | NO        | 6over4        |

**Table 15: BGP Fast Reroute Scenarios (Continued)**

| Ingress packet | Context          | Primary route                                                                                                                            | Backup route                                                                                                                             | Supported | Comments                                                                                                                                     |
|----------------|------------------|------------------------------------------------------------------------------------------------------------------------------------------|------------------------------------------------------------------------------------------------------------------------------------------|-----------|----------------------------------------------------------------------------------------------------------------------------------------------|
| IPv6           | GRT              | Labeled-IPv6 (6PE) route with IPv4-mapped IPv6 next-hop A (resolved by tunnel1, which can be any of the following types: ldp, ldp/rsvp). | Labeled-IPv6 (6PE) route with IPv4-mapped IPv6 next-hop B (resolved by tunnel2, which can be any of the following types: ldp, ldp/rsvp). | 9.0R4     | For the best performance the primary and backup next-hops must advertise the same label value with all 6PE routes (e.g. IPv6 explicit null). |
| IPv6           | GRT              | Labeled-IPv6 (6PE) route with IPv4-mapped IPv6 next-hop A (resolved by tunnel1, which can be any of the following types: ldp, ldp/rsvp). | IPv6 route with IPv6 next-hop B (resolved by IPv6 route2)                                                                                | 9.0R4     |                                                                                                                                              |
| MPLS           | Egress IP VPN PE | IPv4 route with CE next-hop A (resolved by IPv4 route1)                                                                                  | IPv4 route with CE next-hop B (resolved by IPv4 route2)                                                                                  | 9.0R4     | VPRN label mode must be VRF.                                                                                                                 |
| MPLS           | Egress IP VPN PE | IPv6 route with CE next-hop A (resolved by IPv6 route1)                                                                                  | IPv6 route with CE next-hop B (resolved by IPv6 route2)                                                                                  | 9.0R4     | VPRN label mode must be VRF.                                                                                                                 |

**Table 15: BGP Fast Reroute Scenarios (Continued)**

| <b>Ingress packet</b> | <b>Context</b>          | <b>Primary route</b>                                                                                                                                    | <b>Backup route</b>                                                                                                                                     | <b>Supported</b> | <b>Comments</b>                                                                                                                                                                      |
|-----------------------|-------------------------|---------------------------------------------------------------------------------------------------------------------------------------------------------|---------------------------------------------------------------------------------------------------------------------------------------------------------|------------------|--------------------------------------------------------------------------------------------------------------------------------------------------------------------------------------|
| IPv4                  | Ingress<br>IP VPN<br>PE | VPN-IPv4 route with RD x, PE next-hop A (resolved by tunnel1, which can be any of the following types: gre, ldp, ldp/rsvp, rsvp, bgp/ldp, or bgp/rsvp). | VPN-IPv4 route with RD y, PE next-hop B (resolved by tunnel2, which can be any of the following types: gre, ldp, ldp/rsvp, rsvp, bgp/ldp, or bgp/rsvp). | 10.0R1           | RD x and RD y can be the same or different. For the best performance the primary and backup next-hops must advertise the same VPRN label value with all routes (e.g. per VRF label). |
| IPv6                  | Ingress<br>IP VPN<br>PE | VPN-IPv6 route with RD x, PE next-hop A (resolved by tunnel1, which can be any of the following types: gre, ldp, ldp/rsvp, rsvp, bgp/ldp, or bgp/rsvp). | VPN-IPv6 route with RD y, PE next-hop B (resolved by tunnel2, which can be any of the following types: gre, ldp, ldp/rsvp, rsvp, bgp/ldp, or bgp/rsvp). | 10.0R1           | RD x and RD y can be the same or different. For the best performance the primary and backup next-hops must advertise the same VPRN label value with all routes (e.g. per VRF label). |

**Table 15: BGP Fast Reroute Scenarios (Continued)**

| <b>Ingress packet</b> | <b>Context</b>         | <b>Primary route</b>                                             | <b>Backup route</b>                                                                                                                                                                | <b>Supported</b> | <b>Comments</b>                                                                                                                                                                                                                                               |
|-----------------------|------------------------|------------------------------------------------------------------|------------------------------------------------------------------------------------------------------------------------------------------------------------------------------------|------------------|---------------------------------------------------------------------------------------------------------------------------------------------------------------------------------------------------------------------------------------------------------------|
| MPLS                  | Egress<br>IP VPN<br>PE | IPv4 route with CE<br>next-hop A<br>(resolved by IPv4<br>route1) | VPN-IPv4 route<br>with RD y, PE<br>next-hop B<br>(resolved by<br>tunnel2, which<br>can be any of the<br>following types:<br>gre, ldp, ldp/rsvp,<br>rsvp, bgp/ldp, or<br>bgp/rsvp). | 10.0R1           | VPRN label<br>mode must be<br>VRF. VPRN<br>must export<br>its VPN-IP<br>routes with<br>RD $\neq$ y. For<br>the best<br>performance<br>the backup<br>next-hop must<br>advertise the<br>same VPRN<br>label value<br>with all routes<br>(e.g. per VRF<br>label). |
| MPLS                  | Egress<br>IP VPN<br>PE | IPv6 route with CE<br>next-hop A<br>(resolved by IPv6<br>route1) | VPN-IPv6 route<br>with RD y, PE<br>next-hop B<br>(resolved by<br>tunnel2, which<br>can be any of the<br>following types:<br>gre, ldp, ldp/rsvp,<br>rsvp, bgp/ldp, or<br>bgp/rsvp). | 10.0R1           | VPRN label<br>mode must be<br>VRF. VPRN<br>must export<br>its VPN-IP<br>routes with<br>RD $\neq$ y. For<br>the best<br>performance<br>the backup<br>next-hop must<br>advertise the<br>same VPRN<br>label value<br>with all routes<br>(e.g. per VRF<br>label). |

**Table 15: BGP Fast Reroute Scenarios (Continued)**

| Ingress packet | Context           | Primary route                                                                                                                                           | Backup route                                            | Supported | Comments |
|----------------|-------------------|---------------------------------------------------------------------------------------------------------------------------------------------------------|---------------------------------------------------------|-----------|----------|
| IPv4           | Ingress IP VPN PE | VPN-IPv4 route with RD x, PE next-hop A (resolved by tunnel1, which can be any of the following types: gre, ldp, ldp/rsvp, rsvp, bgp/ldp, or bgp/rsvp). | IPv4 route with CE next-hop B (resolved by IPv4 route2) | NO        |          |

Figure 26 shows an example of BGP fast reroute in an ingress PE router when a remote PE connected to a multi-homed site is taken out of service.

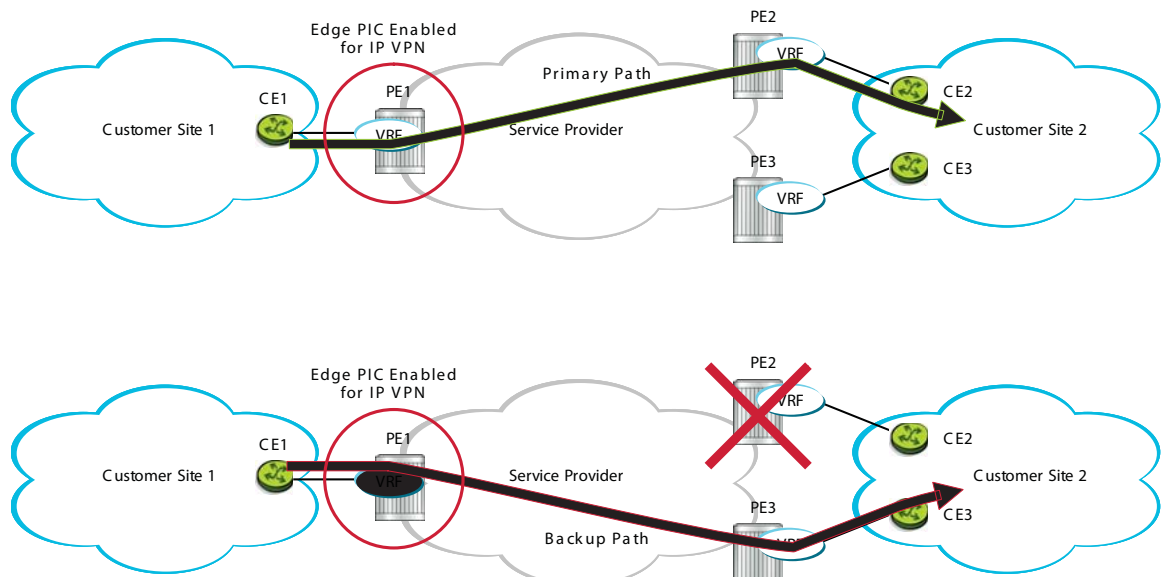

**Figure 26: BGP Fast Reroute for Remote PE Router Failure**

### Calculating Backup Paths

When BGP fast reroute is enabled, the control plane is responsible for selecting one or more primary paths, and if possible, a backup path for each destination IP prefix. The primary paths are the routes tied for best according to the BGP multipath configuration.

The backup path is the single best path remaining after the primary ECMP paths and any paths with the same BGP next-hops as these paths have been removed.

---

### **Sending Failure Notifications to the IOM**

When BGP fast reroute is enabled, the IOM reroutes traffic onto a backup path based on input from BGP. When BGP decides that a primary path is no longer usable, it sends message to the IOM indicating that the corresponding BGP next-hop is unreachable/ unresolved. If this results in all of the primary paths being unresolved, the IOM switches affected traffic to the backup path.

These are some of events that can trigger the sending of a next-hop down message to the IOM:

- TCP session closed with the neighbor.
- BGP session terminated with the neighbor.
- Fast-external failover is enabled and the interface with a single-hop EBGP neighbor goes down.
- Peer tracking is enabled and there is no route to the peer address of the neighbor.
- BFD is enabled with a neighbor and the BFD session goes down.
- There is no active IP route that matches the BGP next-hop address.



## Command Interactions and Dependencies

This section highlights the BGP command interactions and dependencies which are important for configuration or operational maintenance of 7750 SR routers. Topics covered in this section are:

- [Changing the Autonomous System Number on page 593](#)
- [Changing a Confederation Number on page 594](#)
- [Changing the Router ID at the Configuration Level on page 594](#)
- [Changing the Local AS Number on page 594](#)
- [Hold Time and Keep Alive Timer Dependencies on page 595](#)
- [Import and Export Route Policies on page 596](#)
- [Route Damping and Route Policies on page 596](#)

Note that this information can be found in the [BGP Command Reference on page 629](#) which provides detailed descriptions of the configuration commands.

---

### Changing the Autonomous System Number

If the AS number is changed on a router with an active BGP instance (that is at the `config>router>level`), the new AS number will not be used until the BGP instance is restarted either by administratively disabling and enabling the BGP instance or by rebooting the system with the new configuration.

## Changing the Local AS Number

Changing the local AS of an active BGP instance:

- At the global level causes the BGP instance to restart with the new local AS number.
  - At the group level causes BGP to re-establish the peer relationships with all peers in the group with the new local AS number.
  - At the neighbor level causes BGP to re-establish the peer relationship with the new local AS number.
- 

## Changing a Confederation Number

Changing the a confederation value on an active BGP instance will not restart the protocol. The change will take affect when the BGP protocol is (re) initialized.

---

## Changing the Router ID at the Configuration Level

If you configure a new router ID in the `config>router` context, protocols are not automatically restarted with the new router ID. The next time a protocol is (re) initialized the new router ID is used. An interim period of time can occur when different protocols use different router IDs.

## Hold Time and Keep Alive Timer Dependencies

The BGP hold time specifies the maximum time BGP will wait between successive messages (either keep alive or update) from its peer, before closing the connection. This configuration parameter can be set at three levels. The most specific value is used.

- Global level — applies to all peers
- Group level — applies to all peers in group
- Neighbor level — only applies to specified peer

Although the keep alive time can be user specified, the configured keep alive timer is overridden by the value of hold time under the following circumstances:

- If the hold time specified is less than the configured keep alive time, then the operational keep alive time is set to one third of the specified hold time; the configured keep alive time is unchanged.
- If the hold time is set to zero, then the operational value of the keep alive time is set to zero; the configured keep alive time is unchanged. This means that the connection with the peer will be up permanently and no keep alive packets are sent to the peer.

If the hold time or keep alive values are changed, the changed timer values take effect when the new peering relationship is established. Changing the values cause the peerings to restart. The changed timer values are used when re-negotiating the peer relationship.

## Import and Export Route Policies

Import and export route policy statements are specified for BGP on the global, group, and neighbor level. Up to five unique policy statement names can be specified in the command line per level. The most specific command is applied to the peer. Defining the policy statement name is not required before being applied. Policy statements are evaluated in the order in which they are specified within the command context.



**NOTE:** You can use the *keep* option for VPRN related routes to remove the need to send route refresh messages; see [mp-bgp-keep on page 666](#). When enabled, BGP maintains all VPRN related routes descriptive information.

The import and export policies configured on different levels are not cumulative. The most specific value is used. An `import` or `export` policy command specified on the neighbor level takes precedence over the same command specified on the group or global level. An `import` or `export` policy command specified on the group level takes precedence over the same command specified on the global level.

---

## Route Damping and Route Policies

To prevent BGP systems from sending excessive route changes to peers, BGP route damping can be implemented. Damping can reduce the number of update messages sent between BGP peers, to reduce the load on peers, without adversely affecting the route convergence time for stable routes.

The damping profile defined in the policy statement is applied to control route damping parameters. Route damping characteristics are specified in a route damping profile and are referenced in the action for the policy statement or in the action for a policy entry. Damping can be specified at the global, group, or neighbor level with the most specific command applied to the peer.

---

## AS Override

AS Override simplifies the use of the same AS number (ASN) across multiple VPRN sites.

The AS Override feature can be used in VPRN scenarios where a customer is running BGP as the PE-CE protocol and some or all of the CE locations are in the same Autonomous System (AS). With normal BGP, two sites in the same AS would not be able to reach each other directly since there is an apparent loop in the AS\_PATH.

With AS Override enabled on an egress eBGP session, the PE rewrites the customer ASN in the AS\_PATH with the VPRN AS number as the route is advertised to the CE.

## BGP FlowSpec

FlowSpec is a standardized method (defined in RFC 5575) for using BGP to distribute traffic flow specifications (flow routes) throughout a network. A flow route carries a description of a flow in terms of packet header fields such as source IP address, destination IP address, or TCP/UDP port number and indicates (through a community attribute) an action to take on packets matching the flow. The primary application for Flowspec is DDoS mitigation.

Flowspec is supported by SROS only by the base router BGP instance and only for IPv4 packets. To exchange IPv4 FlowSpec routes with a BGP peer, the MP-BGP capability for AFI 1 and SAFI 133 must be negotiated when the session is established. The flow-ipv4 keyword must be part of the family command (at the BGP instance, group, or neighbor level) for this capability negotiation to occur.

The NLRI of an IPv4 flow route can contain one or more of the subcomponents shown in [Table 16](#).

**Table 16: Subcomponents of IPv4 Flow Route NLRI**

| Subcomponent Name<br>[Type] | Value Encoding                        | SROS Support                                                     |
|-----------------------------|---------------------------------------|------------------------------------------------------------------|
| Destination IPv4 Prefix [1] | Prefix length, prefix                 | Yes                                                              |
| Source IPv4 Prefix [2]      | Prefix length, prefix                 | Yes                                                              |
| IP Protocol [3]             | One or more (operator, value) pairs   | Partial. No support for multiple values other than “TCP or UDP”. |
| Port [4]                    | One or more (operator, value) pairs   | No                                                               |
| Destination Port [5]        | One or more (operator, value) pairs   | Partial. No support for multiple ranges.                         |
| Source Port [6]             | One or more (operator, value) pairs   | Partial. No support for multiple ranges.                         |
| ICMP Type [7]               | One or more (operator, value) pairs   | Partial. Only a single value is supported.                       |
| ICMP Code [8]               | One or more (operator, value) pairs   | Partial. Only a single value is supported.                       |
| TCP Flags [9]               | One or more (operator, bitmask) pairs | Partial. Only SYN and ACK flags can be matched.                  |
| Packet Length [10]          | One or more (operator, value) pairs   | No                                                               |
| DSCP [11]                   | One or more (operator, value) pairs   | Partial. Only a single value is supported.                       |

**Table 16: Subcomponents of IPv4 Flow Route NLRI (Continued)**

| Subcomponent Name<br>[Type] | Value Encoding                        | SROS Support                                                              |
|-----------------------------|---------------------------------------|---------------------------------------------------------------------------|
| Fragment [12]               | One or more (operator, bitmask) pairs | Partial. No support for matching DF bit, first-fragment or last-fragment. |

[Table 17](#) summarizes the actions that may be associated with an IPv4 flow route and how each type of action is encoded.

**Table 17: IPv4 Flowspec Actions**

| Action             | Encoding                              | SROS Support                       |
|--------------------|---------------------------------------|------------------------------------|
| Rate Limit         | Extended community type 0x8006        | Partial. Only rate=0 is supported. |
| Sample/Log         | Extended community type 0x8007. S-bit | Yes                                |
| Next Entry         | Extended community type 0x8007. T-bit | No                                 |
| Redirect to VRF    | Extended community type 0x8008.       | Yes                                |
| Mark Traffic Class | Extended community type 0x8009.       | No                                 |

**Note:** An IPv4 flow route cannot have more than one instance of a flowspec extended community in the range 0x8006-0x8009. If it has more than one instance, a log/trap is generated and no filter entry is installed for the flow route.

## Validating and Importing Received IPv6 Flow Routes into the Routing Table

IPv4 flow routes received from a BGP peer must be validated before being considered for import into the routing table. An IPv4 flow route is considered invalid if:

1. The flow route is received from an EBGP peer and the left most AS number in the AS\_PATH attribute does not equal the peer's AS number (from the group/neighbor configuration).
2. The **flowspec-validate** command is enabled, the flow route has a destination prefix subcomponent D, and the flow route was received from a peer P that did not advertise the best IP route to D and all more-specific prefixes.

After received flow routes are validated they are processed by the relevant import policies.

**Note:** An IPv4 flow route never matches a prefix entry in a prefix-list, even if the destination IPv4 prefix subcomponent or the source IPv4 prefix subcomponent of the NLRI is a match.

If the router receives the exact same IPv4 flow route NLRI from multiple peers then the router selects one best path from among all received paths. The best path selection follows the existing implementation (used for all other BGP NLRI). Step 1 of the algorithm eliminates invalid routes and for IPv4 flow routes. This includes routes that were required to meet the validation checks described by the standard but did not. For each NLRI, the route with the best path is:

- Installed in the LOC-RIB.
- Propagated to BGP peers, depending on export policies.
- Used if possible to create an IPv4 filter entry.

## Propagating IPv4 Flow Routes to BGP Neighbors

When the base router BGP instance installs an IPv4 flow route into its LOC-RIB the default export policy causes it to advertise the flow route to all of its AFI=1/SAFI=133 BGP peers.

User-configured export policies can be used to override the default export policy. Export policy actions do not change the contents of the flow route NLRI in any way.

## Using IPv4 Flow Routes to Create Dynamic IPv4 Filter Entries

When the base router BGP instance installs an IPv4 flow route into its LOC-RIB, the system attempts to construct an ipv4-filter entry from the NLRI contents and the action(s) encoded in the UPDATE message. If successful, the filter entry is added to the system-created ‘fSpec-1’ IPv4 filter policy that internally has an identifier of 16777217. This ‘fSpec-1’ filter policy is applied to the following:

- Ingress IPv4 traffic on a network interface, if the **config>router>interface >ingress** configuration includes the keyword **flowspec**.
- Ingress IPv4 traffic on an IES SAP interface, if the **config>service>ies>interface>sap>ingress** configuration includes the keyword **flowspec**.
- Ingress IPv4 traffic on an IES spoke SDP interface, if the **config>service>ies>interface>spoke-sdp>ingress** configuration includes the keyword **flowspec**.

A user-defined IPv4 filter policy can be applied to a base router interface that has IPv4 flow-spec enabled. When an interface has both a user-defined IPv4 filter policy and the system-created ‘fSpec-1’ IPv4 filter policy, the IPv4 filter rules are installed in the following order:

1. User-defined IPv4 filter entries (in ascending order of entry IDs).

## BGP Overview

- 
2. IPv4 flowspec entries (in order, determined by comparison of the NLRI described in RFC 5575).
3. User-defined IPv4 filter default action.



## TTL Security for BGP and LDP

The BGP TTL Security Hack (BTSH) was originally designed to protect the BGP infrastructure from CPU utilization-based attacks. It is derived on the fact that the vast majority of ISP eBGP peerings are established between adjacent routers. Since TTL spoofing is considered nearly impossible, a mechanism based on an expected TTL value can provide a simple and reasonably robust defense from infrastructure attacks based on forged BGP packets.

While TSH is most effective in protecting directly connected peers, it can also provide a lower level of protection to multi-hop sessions. When a multi-hop BGP session is required, the expected TTL value can be set to 255 minus the configured range-of-hops. This approach can provide a qualitatively lower degree of security for BGP (such as a DoS attack could, theoretically, be launched by compromising a box in the path). However, BTSH will catch a vast majority of observed distributed DoS (DDoS) attacks against eBGP. For further information, refer to draft-gill-btsh-xx.txt, *The BGP TTL Security Hack (BTSH)*.

TSH can be used to protect LDP peering sessions as well. For details, see draft-chen-ldp-ttl-xx.txt, *TTL-Based Security Option for LDP Hello Message*.

The TSH implementation supports the ability to configure TTL security per BGP/LDP peer and evaluate (in hardware) the incoming TTL value against the configured TTL value. If the incoming TTL value is less than the configured TTL value, the packets are discarded and a log is generated.

## BGP Configuration Process Overview

Figure 27 displays the process to provision basic BGP parameters.

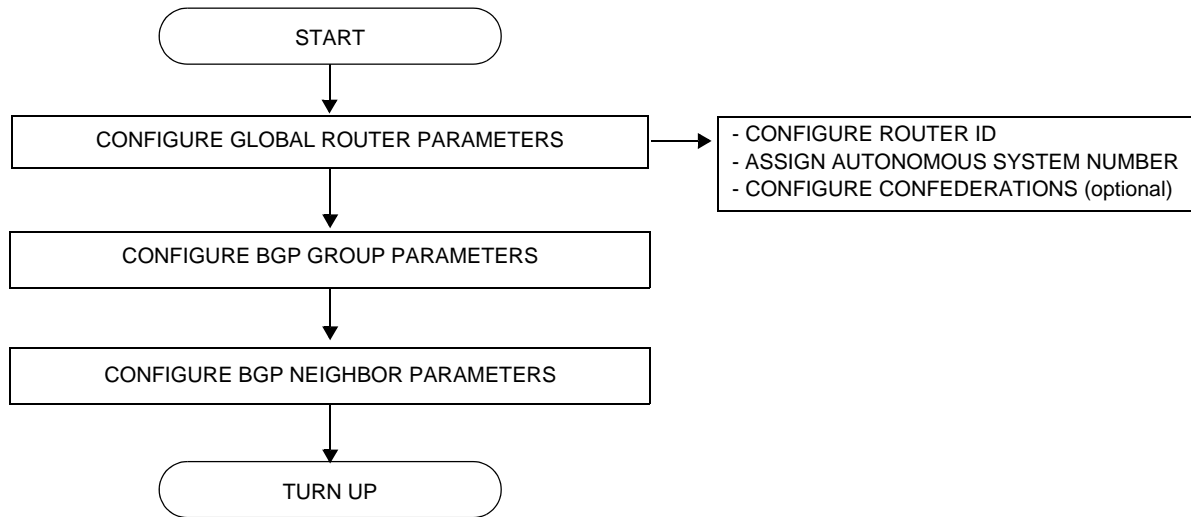

Figure 27: BGP Configuration and Implementation Flow

# Configuration Notes

This section describes BGP configuration caveats.

---

## General

- Before BGP can be configured, the router ID and autonomous system should be configured.
  - BGP must be added to the router configuration. There are no default BGP instances on a 7750 SR.
- 

## BGP Defaults

The following list summarizes the BGP configuration defaults:

- By default, the 7750 SR is not assigned to an AS.
- A BGP instance is created in the administratively enabled state.
- A BGP group is created in the administratively enabled state.
- A BGP neighbor is created in the administratively enabled state.
- No BGP router ID is specified. If no BGP router ID is specified, BGP uses the router system interface address.
- The 7750 SR OS BGP timer defaults are generally the values recommended in IETF drafts and RFCs (see [BGP MIB Notes on page 604](#))
- If no *import* route policy statements are specified, then all BGP routes are accepted.
- If no *export* route policy statements specified, then all best and used BGP routes are advertised and non-BGP routes are not advertised.

## BGP MIB Notes

The 7750 SR OS implementation of the RFC 1657 MIB variables listed in [Table 18](#) differs from the IETF MIB specification.

**Table 18: TiMOS and IETF MIB Variations**

| MIB Variable                         | Description                                                                                                        | RFC 1657 Allowed Values | 7750 SR OS Allowed Values |
|--------------------------------------|--------------------------------------------------------------------------------------------------------------------|-------------------------|---------------------------|
| bgpPeerMinASOriginationInterval      | Time interval in seconds for the MinASOriginationInterval timer. The suggested value for this timer is 15 seconds. | 1 — 65535               | 2 — 255                   |
| bgpPeerMinRouteAdvertisementInterval | Time interval in seconds for the MinRouteAdvertisementInterval timer. The suggested value for this timer is 30.    | 1 — 65535               | <sup>a</sup> 1 — 255      |

a. A value of 0 is supported when the rapid-update command is applied to an address family that supports it.

If SNMP is used to set a value of X to the MIB variable in [Table 19](#), there are three possible results:

**Table 19: MIB Variable with SNMP**

| Condition                                                       | Result                                                                                                                                                                                                             |
|-----------------------------------------------------------------|--------------------------------------------------------------------------------------------------------------------------------------------------------------------------------------------------------------------|
| X is within IETF MIB values and X is within 7750 SR OS values   | SNMP set operation does not return an error<br>MIB variable set to X                                                                                                                                               |
| X is within IETF MIB values and X is outside 7750 SR OS values  | SNMP set operation does not return an error<br>MIB variable set to “nearest” 7750 SR OS supported value (e.g. 7750 SR OS range is 2 - 255 and X = 65535, MIB variable will be set to 255)<br>Log message generated |
| X is outside IETF MIB values and X is outside 7750 SR OS values | SNMP set operation returns an error                                                                                                                                                                                |

When the value set using SNMP is within the IETF allowed values and outside the TiMOS values as specified in [Table 18](#) and [Table 19](#), a log message is generated.

The log messages that display are similar to the following log messages:

**Sample Log Message for setting bgpPeerMinASOriginationInterval to 65535**

```
576 2006/11/12 19:45:48 [Snmpd] BGP-4-bgpVariableRangeViolation: Trying
to set bgpPeerMinASOrigInt to 65535 - valid range is [2-255] - setting to
255
```

**Sample Log Message for setting bgpPeerMinASOriginationInterval to 1**

```
594 2006/11/12 19:48:05 [Snmpd] BGP-4-bgpVariableRangeViolation: Trying
to set bgpPeerMinASOrigInt to 1 - valid range is [2-255] - setting to 2
```

**Sample Log Message for setting bgpPeerMinRouteAdvertisementInterval to 256**

```
535 2006/11/12 19:40:53 [Snmpd] BGP-4-bgpVariableRangeViolation: Trying
to set bgpPeerMinRouteAdvInt to 256 - valid range is [2-255] - setting to
255
```

**Sample Log Message for setting bgpPeerMinRouteAdvertisementInterval to 1**

```
566 2006/11/12 19:44:41 [Snmpd] BGP-4-bgpVariableRangeViolation: Trying
to set bgpPeerMinRouteAdvInt to 1 - valid range is [2-255] - setting to 2
```



## Configuring BGP with CLI

This section provides information to configure BGP using the command line interface.

Topics in this section include:

- [BGP Configuration Overview on page 608](#)
  - [Preconfiguration Requirements on page 608](#)
  - [BGP Hierarchy on page 608](#)
  - [Internal and External BGP Configurations on page 608](#)
  - [BGP Confederations on page 615](#)
  - [BGP Route Reflectors on page 617](#)
- [Basic BGP Configuration on page 610](#)
- [Common Configuration Tasks on page 612](#)
  - [Creating an Autonomous System on page 613](#)
  - [Configuring a Router ID on page 614](#)
  - [BGP Components on page 619](#)
  - [Configuring Group Attributes on page 620](#)
  - [Configuring Neighbor Attributes on page 621](#)
  - [Configuring Route Reflection on page 622](#)
  - [Configuring a Confederation on page 623](#)
- [BGP Configuration Management Tasks on page 624](#)
  - [Modifying an AS Number on page 624](#)
  - [Modifying the BGP Router ID on page 625](#)
  - [Deleting a Neighbor on page 627](#)
  - [Deleting Groups on page 628](#)

## BGP Configuration Overview

---

### Preconfiguration Requirements

Before BGP can be implemented, the following entities must be configured:

- The autonomous system (AS) number for the router.  
An AS number is a globally unique value which associates a router to a specific autonomous system. This number is used to exchange exterior routing information with neighboring ASs and as an identifier of the AS itself. Each router participating in BGP must have an AS number specified.  
In order to implement BGP, the AS number must be specified in the `config>router` context.
  - Router ID — The router ID is the IP address of the local router. The router ID identifies a packet's origin. The router ID must be a valid host address.
- 

### BGP Hierarchy

BGP is configured in the `config>router>bgp` context. Three hierarchical levels are included in BGP configurations:

- Global level
- Group level
- Neighbor level

Commands and parameters configured on the global level are inherited to the group and neighbor levels although parameters configured on the group and neighbor levels take precedence over global configurations.

---

### Internal and External BGP Configurations

A BGP system is comprised of ASs which share network reachability information. Network reachability information is shared with adjacent BGP peers. BGP supports two types of routing information exchanges:

- External BGP (EBGP) is used between ASs.



EBGP speakers peer to different ASs and typically share a subnet. In an external group, the next hop is dependent upon the interface shared between the external peer and the specific neighbor. The `multihop` command must be specified if an EBGP peer is more than one hop away from the local router.

- Internal BGP (IBGP) is used within an AS.

IBGP peers belong to the same AS and typically does not share a subnet. Neighbors do not have to be directly connected to each other. Since IBGP peers are not required to be directly connected, IBGP uses the IGP path (the IP next-hop learned from the IGP) to reach an IBGP peer for its peering connection.

## Basic BGP Configuration

This section provides information to configure BGP and configuration examples of common configuration tasks. The minimal BGP parameters that need to be configured are:

- An autonomous system number for the router.
- A router ID - Note that if a new or different router ID value is entered in the BGP context, then the new value takes precedence and overwrites the router-level router ID.
- A BGP peer group.
- A BGP neighbor with which to peer.
- A BGP peer-AS that is associated with the above peer.

The BGP configuration commands have three primary configuration levels: **bgp** for global configurations, **group name** for BGP group configuration, and **neighbor ip-address** for BGP neighbor configuration. Within the different levels, many of the configuration commands are repeated. For the repeated commands, the command that is most specific to the neighboring router is in effect, that is, neighbor settings have precedence over group settings which have precedence over BGP global settings.

Following is a sample configuration that includes the above parameters. The other parameters shown below are optional:

```
info
#-----
echo "IP Configuration"
#-----
...
 autonomous-system 200
 confederation 300 members 200 400 500 600
 router-id 10.10.10.103
#-----
...
#-----
echo "BGP Configuration"
#-----
 bgp
 graceful-restart
 exit
 cluster 0.0.0.100
 export "direct2bgp"
 router-id 10.0.0.12
 group "To_AS_10000"
 connect-retry 20
 hold-time 90
 keepalive 30
 local-preference 100
 remove-private
 peer-as 10000
 neighbor 10.0.0.8
 description "To_Router B - EBGP Peer"
```

```
 connect-retry 20
 hold-time 90
 keepalive 30
 local-address 10.0.0.12
 passive
 preference 99
 peer-as 10000
 exit
exit
group "To_AS_30000"
 connect-retry 20
 hold-time 90
 keepalive 30
 local-preference 100
 remove-private
 peer-as 30000
 neighbor 10.0.3.10
 description "To_Router C - EBGP Peer"
 connect-retry 20
 hold-time 90
 keepalive 30
 peer-as 30000
 exit
exit
group "To_AS_40000"
 connect-retry 20
 hold-time 30
 keepalive 30
 local-preference 100
 peer-as 65206
 neighbor 10.0.0.15
 description "To_Router E - Sub Confederation AS 65205"
 connect-retry 20
 hold-time 90
 keepalive 30
 local-address 10.0.0.12
 peer-as 65205
 exit
exit
exit
#-----
....
A:ALA-48>config>router#
```

## Common Configuration Tasks

This section provides a brief overview of the tasks that must be performed to configure BGP and provides the CLI commands. In order to enable BGP, one AS must be configured and at least one group must be configured which includes neighbor (system or IP address) and peering information (AS number).

All BGP instances must be explicitly created on each 7750 SR-Series. Once created, BGP is administratively enabled.

Configuration planning is essential to organize ASs and the SRs within the ASs, and determine the internal and external BGP peering.

To configure a basic autonomous system, perform the following tasks:

1. Prepare a plan detailing the autonomous system(s), the 7750 SR-Series belonging to each group, group names, and peering connections.
2. Associate each 7750 SR-Series with an autonomous system number.
3. Configure each 7750 SR-Series with a router ID.
4. Associate each 7750 SR-Series with a peer group name.
5. Specify the local IP address that will be used by the group or neighbor when communicating with BGP peers.
6. Specify neighbors.
7. Specify the autonomous system number associated with each neighbor.

## Creating an Autonomous System

Before BGP can be configured, the autonomous system must be configured first. In BGP, routing reachability information is exchanged between autonomous systems (ASs). An AS is a group of networks that share routing information. The **autonomous-system** command associates an autonomous system number to the router being configured. The `autonomous-system` command is configured in the **config>router** context.

Use the following CLI syntax to associate a 7750 SR-Series to an autonomous system:

**CLI Syntax:** `config>router# autonomous-system autonomous-system`

The 7750 SR-Series series supports 4 bytes AS numbers by default. This means `autonomous-system` can have any value from 1 to 4294967295. The following example displays autonomous system configuration command usage:

**Example:** `config>router# autonomous-system 100`

The following example displays the autonomous system configuration:

```
ALA-B>config>router# info
#-----
IP Configuration
#-----
 interface "system"
 address 10.10.10.104/32
 exit
 interface "to-103"
 address 10.0.0.104/24
 port 1/1/1
 exit
 autonomous-system 100

#-----
ALA-B>config>router#
```

## Configuring a Router ID

In BGP, routing information is exchanged between autonomous systems. The BGP router ID, expressed like an IPv4 address, uniquely identifies the router. It can be set to be the same as the system interface address.

Note that if a new or different router ID value is entered in the BGP context, then the new router ID value is used instead of the router ID configured on the router level, system interface level, or inherited from the MAC address. The router-level router ID value remains intact. The router ID used by BGP is selected in the following order:

- The `routed-id` configured under **config>router>bgp**
- The `router-id` configured under **config>router**
- The system interface IPv4 address
- The last 4 bytes of the system MAC address

When configuring a new router ID outside of the **config>router>bgp** context, BGP is not automatically restarted with the new router ID; the next time BGP is (re) initialized the new router ID is used. An interim period of time can occur when different protocols use different router IDs. To force the new router ID, issue the `shutdown` and `no shutdown` commands for BGP or restart the entire router. Use the following CLI syntax to configure the router ID for multiple protocols:

**CLI Syntax:** `config>router# router-id router-id`

The following example displays router ID configuration command usage:

**Example:** `config>router# router-id 10.10.10.104`

The following example displays the router ID configuration:

```
ALA-B>config>router# info

IP Configuration
#-----
 interface "system"
 address 10.10.10.104/32
 exit
 interface "to-103"
 address 10.0.0.104/24
 port 1/1/1
 exit
 autonomous-system 100
 router-id 10.10.10.104
#-----
...
ALA-B>config>router#
```

## BGP Confederations

Follow these steps to configure a confederation:

1. Configure the autonomous system number of the confederation using the confederation command in the **config>router** context..
2. Configure the BGP confederation members using the confederation command in the config>router context.
3. Configure IBGP peering within the (local) sub-confederation.
4. Configure one or more confed-EBGP peerings to peers in other neighboring sub-confederations.

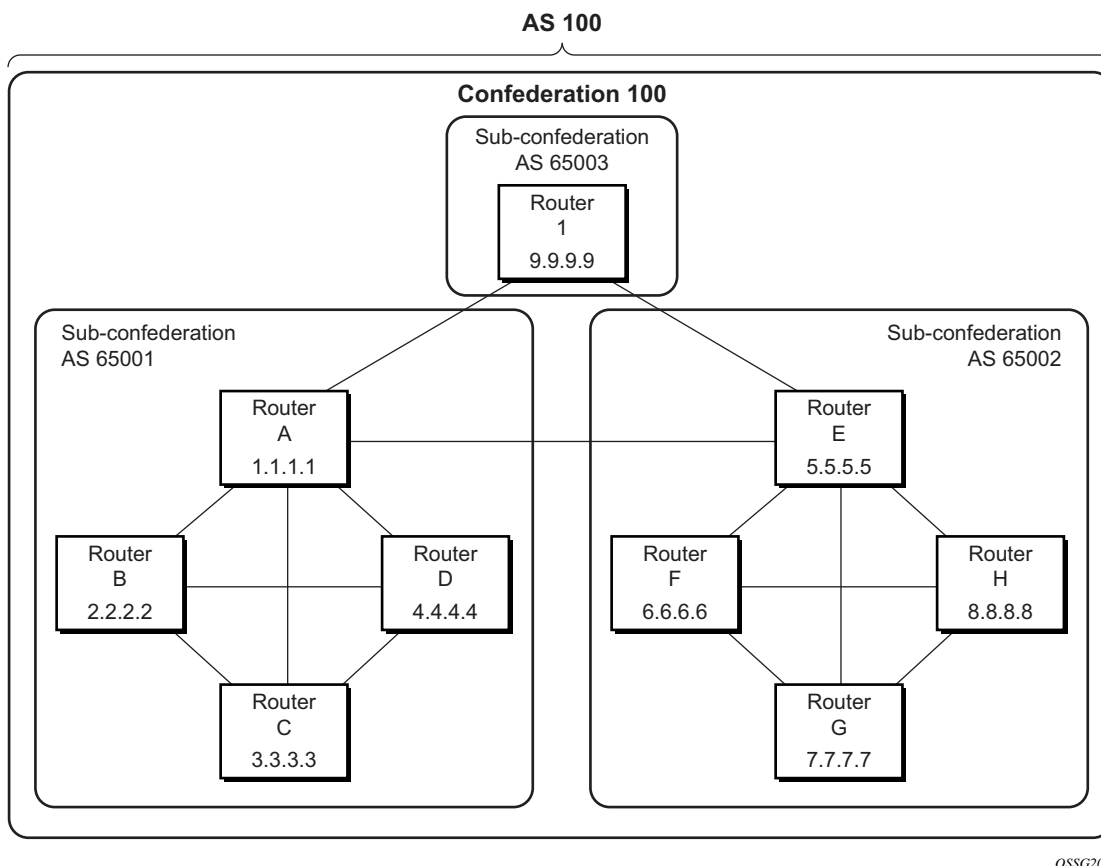

**Figure 28: Confederation Network Diagram Example**

The following configuration displays the minimum BGP configuration for routers in sub-confederation AS 65001 outlined in [Figure 29](#).

## Common Configuration Tasks

```
ALA-A
 config router
 autonomous-system 65001
 confederation 100 members 65001 65002 65003
 bgp
 group confed1
 peer-as 65001
 neighbor 2.2.2.2
 exit
 neighbor 3.3.3.3
 exit
 neighbor 4.4.4.4
 exit
 exit
 group external_confed
 neighbor 5.5.5.5
 peer-as 65002
 exit
 neighbor 9.9.9.9
 peer-as 65003
 exit
 exit
 exit
 exit
```

```
ALA-D
 config router
 autonomous-system 65001
 confederation 100 members 65001 65002 65003
 bgp
 group confed1
 peer-as 65001
 neighbor 1.1.1.1
 exit
 neighbor 2.2.2.2
 exit
 neighbor 3.3.3.3
 exit
 exit
 exit
 exit
```

```
ROUTER 1
 config router
 autonomous-system 65003
 confederation 100 members 65001 65002 65003
 bgp
 group confed1
 peer-as 65001
 neighbor 1.1.1.1
 exit
 neighbor 5.5.5.5
 peer-as 65002
 exit
 exit
 exit
 exit
```



## BGP Route Reflectors

In a standard BGP configuration, all BGP speakers within an AS must have a full BGP mesh to ensure that all externally learned routes are redistributed through the entire AS. IBGP speakers do not re-advertise routes learned from one IBGP peer to another IBGP peer. If a network grows, scaling issues could emerge because of the full mesh configuration requirement. Route reflection circumvents the full mesh requirement but still maintains the full distribution of external routing information within an AS.

Autonomous systems using route reflection arrange BGP routers into groups called *clusters*. Each cluster contains at least one route reflector which is responsible for redistributing route updates to all clients. Route reflector clients do not need to maintain a full peering mesh between each other. They only require a peering to the route reflector(s) in their cluster. The route reflectors must maintain a full peering mesh between all non-clients within the AS.

Each route reflector must be assigned a cluster ID and specify which neighbors are clients and which are non-clients to determine which neighbors should receive reflected routes and which should be treated as a standard IBGP peer. Additional configuration is not required for the route reflector besides the typical BGP neighbor parameters.

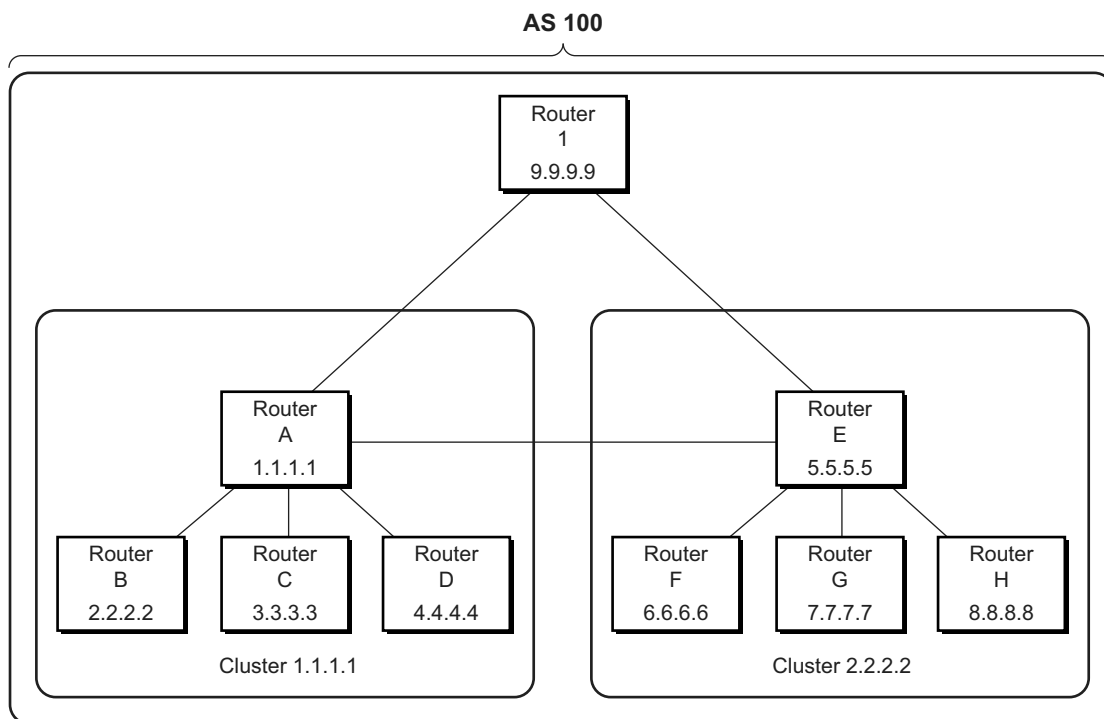

OSSG273

Figure 29: Route Reflection Network Diagram Example

## Common Configuration Tasks

The following configuration displays the minimum BGP configuration for routers in Cluster 1.1.1.1 outlined in [Figure 29](#).

```
ALA-A
 config router bgp
 group cluster1
 peer-as 100
 cluster 1.1.1.1
 neighbor 2.2.2.2
 exit
 neighbor 3.3.3.3
 exit
 neighbor 4.4.4.4
 exit
 exit
 group RRs
 peer-as 100
 neighbor 5.5.5.5
 exit
 neighbor 9.9.9.9
 exit
 exit
exit
```

```
ALA-B
 config router bgp
 group cluster1
 peer-as 100
 neighbor 1.1.1.1
 exit
 exit
 exit
```

```
ALA-C
 config router bgp
 group cluster1
 peer-as 100
 neighbor 1.1.1.1
 exit
 exit
 exit
```

```
ALA-D
 config router bgp
 group cluster1
 peer-as 100
 neighbor 1.1.1.1
 exit
 exit
 exit
```

## BGP Components

Use the CLI syntax displayed below to configure the following BGP attributes:

- [BGP Components on page 619](#)
  - [Configuring Group Attributes on page 620](#)
  - [Configuring Neighbor Attributes on page 621](#)
  - [Configuring Route Reflection on page 622](#)
  - [Configuring a Confederation on page 623](#)
-

## Configuring Group Attributes

A group is a collection of related BGP peers. The group name should be a descriptive name for the group. Follow your group, name, and ID naming conventions for consistency and to help when troubleshooting faults.

All parameters configured for a peer group are applied to the group and are inherited by each peer (neighbor), but a group parameter can be overridden on a specific neighbor-level basis.

The following example displays the BGP group configuration:

```
ALA-B>config>router>bgp# info

...
 group "headquarters1"
 description "HQ execs"
 local-address 10.0.0.104
 disable-communities standard extended
 ttl-security 255
 exit
 exit
...

ALA-B>config>router>bgp#
```

## Configuring Neighbor Attributes

After you create a group name and assign options, add neighbors within the same autonomous system to create IBGP connections and/or neighbors in different autonomous systems to create EBGP peers. All parameters configured for the peer group level are applied to each neighbor, but a group parameter can be overridden on a specific neighbor basis.

The following example displays neighbors configured in group “headquarters1”.

```
ALA-B>config>router>bgp# info

...
 group "headquarters1"
 description "HQ execs"
 local-address 10.0.0.104
 disable-communities standard extended
 ttl-security 255
 neighbor 10.0.0.5
 passive
 peer-as 300
 exit
 neighbor 10.0.0.106
 peer-as 100
 exit
 neighbor 17.5.0.2
 hold-time 90
 keepalive 30
 min-as-origination 15
 local-preference 170
 peer-as 10701
 exit
 neighbor 17.5.1.2
 hold-time 90
 keepalive 30
 min-as-origination 15
 local-preference 100
 min-route-advertisement 30
 preference 170
 peer-as 10702
 exit
 exit
...

ALA-B>config>router>bgp#
```

## Configuring Route Reflection

Route reflection can be implemented in autonomous systems with a large internal BGP mesh to reduce the number of IBGP sessions required. One or more routers can be selected to act as focal points for internal BGP sessions. Several BGP speaking routers can peer with a route reflector. A route reflector forms peer connections to other route reflectors. A router assumes the role as a route reflector by configuring the `cluster cluster-id` command. No other command is required unless you want to disable reflection to specific peers.

If you configure the `cluster` command at the global level, then all subordinate groups and neighbors are members of the cluster. The route reflector cluster ID is expressed in dotted decimal notation. The ID should be a significant topology-specific value. No other command is required unless you want to disable reflection to specific peers.

If a route reflector client is fully meshed, the `disable-client-reflect` command can be enabled to stop the route reflector from reflecting redundant route updates to a client.

The following example displays a route reflection configuration:

```
ALA-B>config>router>bgp# info

 cluster 0.0.0.100
 group "Santa Clara"
 local-address 10.0.0.103
 neighbor 10.0.0.91
 peer-as 100
 exit
 neighbor 10.0.0.92
 peer-as 100
 exit
 neighbor 10.0.0.93
 disable-client-reflect
 peer-as 100
 exit
 exit

ALA-B>config>router>bgp#
```

## Configuring a Confederation

Reducing a complicated IBGP mesh can be accomplished by dividing a large autonomous system into smaller autonomous systems. The smaller ASs can be grouped into a confederation. A confederation looks like a single AS to routers outside the confederation. Each confederation is identified by its own (confederation) AS number.

To configure a BGP confederation, you must specify a confederation identifier, an AS number expressed as a decimal integer. The collection of autonomous systems appears as a single autonomous system with the confederation number acting as the “all-inclusive” autonomous system number. Up to 15 members (ASs) can be added to a confederation.

**NOTE:** The `confederation` command is configured in the **config>router** context.

Use the following CLI syntax to configure a confederation:

**CLI Syntax:** `config>router# confederation confed-as-num members member-as-num`

When 4-byte AS number support is not disabled on 7750 SR the confederation and any of its members can be assigned an AS number in the range from 1 to 4294967295. The following example displays a confederation configuration command usage:

**Example:** `config>router># confederation 1000 members 100 200 300`

The following example displays the confederation configuration:

```
ALA-B>config>router# info
#-----
IP Configuration
#-----
 interface "system"
 address 10.10.10.103/32
 exit
 interface "to-104"
 shutdown
 address 10.0.0.103/24
 port 1/1/1
 exit
 autonomous-system 100
 confederation 1000 members 100 200 300
 router-id 10.10.10.103
#-----
ALA-B>config>router#
```

## BGP Configuration Management Tasks

This section discusses the following BGP configuration management tasks:

- [Modifying an AS Number on page 624](#)
  - [Modifying a Confederation Number on page 625](#)
  - [Modifying the BGP Router ID on page 625](#)
  - [Modifying the Router-Level Router ID on page 626](#)
  - [Deleting a Neighbor on page 627](#)
  - [Deleting Groups on page 628](#)
- 

### Modifying an AS Number

You can modify an AS number on a 7750 SR-Series but the new AS number will not be used until the BGP instance is restarted either by administratively disabling or enabling the BGP instance or by rebooting the system with the new configuration.

Since the AS number is defined in the **config>router** context, not in the BGP configuration context, the BGP instance is not aware of the change. Re-examine the plan detailing the autonomous system(s), the SRs belonging to each group, group names, and peering connections. Changing an AS number on a 7750 SR-Series could cause configuration inconsistencies if associated **peer-as** values are not also modified as required. At the group and neighbor levels, BGP will re-establish the peer relationships with all peers in the group with the new AS number.

Use the following CLI syntax to change an autonomous system number:

**CLI Syntax:** `config>router# autonomous-system autonomous-system`

**CLI Syntax:** `config>router# bgp  
          group name  
          neighbor ip-addr  
          peer-as asn`

**Example:** `config>router# autonomous-system 400  
config>router# bgp  
config>router>bgp# group headquarters1  
config>router>bgp>group# neighbor 10.10.10.103  
config>router>bgp>group# peer-as 400  
config>router>bgp>group# exit`



## Modifying a Confederation Number

Modifying a confederation number will cause BGP to restart automatically. Changes immediately take effect.

---

## Modifying the BGP Router ID

Changing the router ID number in the BGP context causes the new value to overwrite the router ID configured on the router level, system interface level, or the value inherited from the MAC address. It triggers an immediate reset of all peering sessions.

**Example:**     `config>router>bgp# router-id 10.0.0.123`

This example displays the BGP configuration with the BGP router ID specified:

```
ALA-B>config>router>bgp# info detail

no shutdown
no description
no always-compare-med
ibgp-multipath load-balance
. . .
router-id 10.0.0.123

ALA-B>config>router>bgp#
```

## Modifying the Router-Level Router ID

Changing the router ID number in the `config>router` context causes the new value to overwrite the router ID derive from the system interface address, or the value inherited from the MAC address.

When configuring a new router ID, protocols are not automatically restarted with the new router ID. The next time a protocol is (re) initialized the new router ID is used. An interim period of time can occur when different protocols use different router IDs. To force the new router ID, issue the `shutdown` and `no shutdown` commands for each protocol that uses the router ID or restart the entire router.

Use the following CLI syntax to change a router ID:

**CLI Syntax:** `config>router# router-id router-id`

**Example:** `config>router# router-id 10.10.10.104`  
`config>router# no shutdown`  
`config>router>bgp# shutdown`  
`config>router>bgp# no shutdown`

The following example displays the router ID configuration:

```
ALA-A>config>router# info
#-----
IP Configuration
#-----
 interface "system"
 address 10.10.10.104/32
 exit
 interface "to-103"
 address 10.0.0.104/24
 port 1/1/1
 exit
 autonomous-system 100
 router-id 10.10.10.104

#-----
ALA-B>config>router#
```

## Deleting a Neighbor

In order to delete a neighbor, you must shut down the neighbor before issuing the `no neighbor ip-addr` command.

Use the following CLI syntax to delete a neighbor:

**CLI Syntax:**

```
config>router# bgp
 group name
 no neighbor ip-address
 shutdown
 no peer-as asn
 shutdown
```

**Example:**

```
config>router# bgp
config>router>bgp# group headquarters1
config>router>bgp>group# neighbor 10.0.0.103
config>router>bgp>group>neighbor# shutdown
config>router>bgp>group>neighbor# exit
config>router>bgp>group# no neighbor 10.0.0.103
```

The following example displays the “headquarters1” configuration with the neighbor 10.0.0.103 removed.

```
ALA-B>config>router>bgp# info

 group "headquarters1"
 description "HQ execs"
 local-address 10.0.0.104
 neighbor 10.0.0.5
 passive
 peer-as 300
 exit
exit

ALA-B>config>router>bgp#
```

### Deleting Groups

In order to delete a group, the neighbor configurations must be shut down first. After each neighbor is shut down, you must shut down the group before issuing the `no group name` command.

Use the following CLI syntax to shut down a peer and neighbor and then delete a group:

**CLI Syntax:**

```
config>router# bgp
 no group name
 shutdown
 no neighbor ip-address
 shutdown
 shutdown
```

**Example:**

```
config>router# bgp
config>router>bgp# group headquarters1
config>router>bgp>group# neighbor 10.0.0.105
config>router>bgp>group>neighbor# shutdown
config>router>bgp>group>neighbor# exit
config>router>bgp>group# neighbor 10.0.0.103
config>router>bgp>group# shutdown
config>router>bgp>group# exit
config>router>bgp# no group headquarters1
```

If you try to delete the group without shutting down the peer-group, the following message appears:

```
ALA-B>config>router>bgp# no group headquarters1
MINOR: CLI BGP Peer Group should be shutdown before deleted. BGP Peer
Group not deleted.
```

---

# BGP Command Reference

---

## Command Hierarchies

### Configuration Commands

- [Global BGP Commands on page 629](#)
- [Group BGP Commands on page 632](#)
- [Neighbor BGP Commands on page 634](#)
- [Show Commands on page 636](#)
- [Clear Commands on page 636](#)
- [Debug Commands on page 637](#)

#### config

- **router** *[router-name]*
  - **confederation** *confed-as-num members as-number [as-number... (up to 15 max)]*
  - **no confederation** *[confed-as-num members as-number [as-number... (up to 15 max)]]*
  - **[no] mh-primary-interface** *interface-name*
    - **[no] address** *{ip-address/mask | ip-address netmask}*
    - **[no] description** *description-string*
    - **[no] shutdown**
  - **[no] mh-secondary-interface** *interface-name*
    - **[no] address** *{ip-address/mask | ip-address netmask}*
    - **[no] description** *description-string*
    - **[no] shutdown**
    - **[no] hold-time** *holdover-time*
  - **[no] mh-secondary-interface**
  - **router-id** *id-address*
  - **no router-id**
  - **[no] bgp**
    - **[no] add-paths**
      - **ipv4 send** *send-limit receive [none]*
      - **ipv4 send** *send-limit*
      - **no ipv4**
      - **ipv6 send** *send-limit receive [none]*
      - **ipv6 end** *send-limit*
      - **no ipv6**
      - **vpn-ipv4** *[send send-limit receive [none]]*
      - **vpn-ipv4 end** *send-limit*
      - **no vpn-ipv4**
      - **vpn-ipv6 send** *send-limit receive [none]*
      - **vpn-ipv6 end** *send-limit*
      - **no vpn-ipv6**
    - **[no] advertise-external** *[ipv4] [ipv6]*
    - **[no] advertise-inactive**
    - **[no] aggregator-id-zero**

- **authentication-key** [*authentication-key* | *hash-key*] [**hash** | **hash2**]
- **no authentication-key**
- **auth-keychain** *name*
- **backup-path** [**ipv4**] [**ipv6**] [**vpn-ipv4**] [**vpn-ipv6**]
- **best-path-selection**
  - **always-compare-med** {**zero** | **infinity**}
  - **always-compare-med strict-as** {**zero** | **infinity**}
  - **no always-compare-med**
  - **as-path-ignore** [**ipv4**] [**vpn-ipv4**] [**ipv6**] [**vpn-ipv6**] [**mcast-ipv4**] [**mvpn-ipv4**] [**l2-vpn**]
  - **no as-path-ignore**
  - **ignore-nh-metric**
  - **ignore-router-id**
- [**no**] **bfd-enable**
- **cluster** *cluster-id*
- **no cluster**
- **connect-retry** *seconds*
- **no connect-retry**
- [**no**] **damping**
- **description** *description-string*
- **no description**
- [**no**] **disable-4byte-asn**
- [**no**] **disable-client-reflect**
- **disable-communities** [**standard**] [**extended**]
- **no disable-communities**
- [**no**] **disable-fast-external-failover**
- [**no**] **enable-inter-as-vpn**
- [**no**] **enable-peer-tracking**
- **export** *policy-name* [*policy-name...* (up to 5 max)]
- **no export**
- **family** [**ipv4**] [**vpn-ipv4**] [**ipv6**] [**vpn-ipv6**] [**mcast-ipv4**] [**l2-vpn**] [**mvpn-ipv4**] [**mdt-safi**] [**ms-pw**] [**flow-ipv4**] [**route-target**]
- **no family**
- [**no**] **flowspec-validate**
- [**no**] **graceful-restart**
  - **stale-routes-time** *time*
  - **no stale-routes-time**
- **hold-time** *seconds* [**strict**]
- **no hold-time**
- [**no**] **ibgp-multipath**
- **igp-shortcut** [**ldp** | **rsvp-te** | **mpls**] [**disallow-igp**]
- **no igp-shortcut**
- **import** *policy-name* [*policy-name ...* (up to 5 max)]
- **no import**
- **keepalive** *seconds*
- **no keepalive**
- **local-as** *as-number* [**private**]
- **no local-as**
- **local-preference** *local-preference*
- **no local-preference**
- **loop-detect** {**drop-peer** | **discard-route** | **ignore-loop** | **off**}
- **no loop-detect**
- **med-out** {*number* | **igp-cost**}
- **no med-out**

- **min-as-origination** *seconds*
- **no min-as-origination**
- **min-route-advertisement** *seconds*
- **no min-route-advertisement**
- **[no] mp-bgp-keep**
- **multihop** *ttl-value*
- **no multihop**
- **multipath** *max-paths*
- **no multipath**
- **[no] outbound-route-filtering**
  - **[no] extended-community**
    - **[no] accept-orf**
    - **send-orf** [*comm-id...*(up to 32 max)]
    - **no send-orf** *comm-id*
- **[no] path-mtu-discovery**
- **preference** *preference*
- **no preference**
- **[no] rapid-update** {[**l2-vpn**] [**mvpn-ipv4**] [**mdt-safi**]}
- **[no] rapid-withdrawal**
- **[no] remove-private**
- **route-target-list** *comm-id* [*comm-id...*(up to 15 max)]
- **no route-target-list** [*comm-id*]
- **router-id** *ip-address*
- **no router-id**
- **[no] shutdown**
- **transport-tunnel** *ldp / rsvp-te / mpls*
- **[no] vpn-apply-export**
- **[no] vpn-apply-import**

```

config
 — router [router-name]
 — [no] bgp
 — [no] group name
 — [no] add-paths
 — ipv4 send send-limit receive [none]
 — ipv4 send send-limit
 — no ipv4
 — ipv6 send send-limit receive [none]
 — ipv6 end send-limit
 — no ipv6
 — vpn-ipv4 [send send-limit receive [none]]
 — vpn-ipv4 end send-limit
 — no vpn-ipv4
 — vpn-ipv6 send send-limit receive [none]
 — vpn-ipv6 end send-limit
 — no vpn-ipv6
 — [no] advertise-inactive
 — [no] aggregator-id-zero
 — authentication-key [authentication-key | hash-key] [hash | hash2]
 — no authentication-key
 — auth-keychain name
 — [no] bfd-enable
 — cluster cluster-id
 — no cluster
 — connect-retry seconds
 — no connect-retry
 — [no] damping
 — [no] default-route-target
 — description description-string
 — no description
 — [no] disable-4byte-asn
 — [no] disable-capability-negotiation
 — [no] disable-client-reflect
 — disable-communities [standard] [extended]
 — no disable-communities
 — [no] disable-fast-external-failover
 — [no] enable-peer-tracking
 — export policy-name [policy-name... (up to 5 max)]
 — no export
 — family [ipv4] [vpn-ipv4] [ipv6] [mcast-ipv4] [l2-vpn] [mvpn-ipv4] [flow-ipv4] [mdt-safi] [route target]
 — no family
 — [no] flowspec-validate
 — [no] graceful-restart
 — stale-routes-time time
 — no stale-routes-time
 — hold-time seconds [strict]
 — no hold-time
 — import policy-name [policy-name ... (up to 5 max)]
 — no import
 — keepalive seconds
 — no keepalive

```



- **local-address** *ip-address*
- **no local-address**
- **local-as** *as-number* [**private**]
- **no local-as**
- **local-preference** *local preference*
- **no local-preference**
- **loop-detect** {**drop-peer** | **discard-route** | **ignore-loop** | **off**}
- **no loop-detect**
- **med-out** {*number* | **igp-cost**}
- **no med-out**
- **min-as-origination** *seconds*
- **no min-as-origination**
- **min-route-advertisement** *seconds*
- **no min-route-advertisement**
- **multihop** *ttl-value*
- **no multihop**
- [**no**] **next-hop-self** {[**ipv4**] [**vpn-ipv4**] [**ipv6**] [**mcast-ipv4**] [**l2-vpn**] } [**multi-homing** *primary-anycast secondary-anycast*]
- [**no**] **outbound-route-filtering**
  - [**no**] **extended-community**
    - [**no**] **accept-orf**
    - **send-orf** [*comm-id...*(up to 32 max)]
    - **no send-orf** [*comm-id*]
- [**no**] **passive**
- [**no**] **path-mtu-discovery**
- **peer-as** *as-number*
- **no peer-as**
- **preference** *preference*
- **no preference**
- **prefix-limit** *limit* [**log-only**] [*threshold percent*]
- **no prefix-limit**
- [**no**] **remove-private**
- [**no**] **shutdown**
- **ttl-security** *min-ttl-value*
- **no ttl-security**
- **type** {**internal** | **external**}
- **no type**
- [**no**] **updated-error-handling**
- [**no**] **vpn-apply-export**
- [**no**] **vpn-apply-import**

```

config
 — router [router-name]
 — [no] bgp
 — [no] group name
 — [no] neighbor ip-address
 — [no] add-paths
 — ipv4 send send-limit receive [none]
 — ipv4 send send-limit
 — no ipv4
 — ipv6 send send-limit receive [none]
 — ipv6 end send-limit
 — no ipv6
 — vpn-ipv4 [send send-limit receive [none]]
 — vpn-ipv4 end send-limit
 — no vpn-ipv4
 — vpn-ipv6 send send-limit receive [none]
 — vpn-ipv6 end send-limit
 — no vpn-ipv6
 — [no] advertise-inactive
 — advertise-label [ipv4 [include-ldp-prefix]] [ipv6]
 — [no] advertise-label
 — [no] aggregator-id-zero
 — auth-keychain name
 — authentication-key [authentication-key | hash-key] [hash | hash2]
 — no authentication-key
 — [no] bfd-enable
 — cluster cluster-id
 — no cluster
 — connect-retry seconds
 — no connect-retry
 — [no] damping
 — [no] default-route-target
 — description description-string
 — no description
 — [no] disable-4byte-asn
 — [no] disable-capability-negotiation
 — [no] disable-client-reflect
 — disable-communities [standard] [extended]
 — no disable-communities
 — [no] disable-fast-external-failover
 — [no] enable-peer-tracking
 — export policy-name [policy-name... (up to 5 max)]
 — no export
 — family [ipv4] [vpn-ipv4] [ipv6] [mcast-ipv4] [l2-vpn] [mvpn-ipv4]
 [flow-ipv4] [mdt-safi] [route-target]
 — no family
 — [no] flowspec-validate
 — [no] graceful-restart
 — stale-routes-time time
 — no stale-routes-time
 — hold-time seconds [strict]
 — no hold-time
 — import policy-name [policy-name ... (up to 5 max)]

```

- **no import**
- **keepalive** *seconds*
- **no keepalive**
- **local-address** *ip-address*
- **no local-address**
- **local-as** *as-number* [**private**]
- **no local-as**
- **local-preference** *local-preference*
- **no local-preference**
- **loop-detect** {**drop-peer** | **discard-route** | **ignore-loop** | **off**}
- **no loop-detect**
- **med-out** {*number* | **igp-cost**}
- **no med-out**
- **min-as-origination** *seconds*
- **no min-as-origination**
- **min-route-advertisement** *seconds*
- **no min-route-advertisement**
- **multihop** *ttl-value*
- **no multihop**
- [**no**] **next-hop-self**
- [**no**] **outbound-route-filtering**
  - [**no**] **extended-community**
    - [**no**] **accept-orf**
      - **send-orf** [*comm-id...*(up to 32 max)]
      - **no send-orf** [*comm-id*]
- [**no**] **passive**
- [**no**] **path-mtu-discovery**
- **peer-as** *as-number*
- **no peer-as**
- **preference** *preference*
- **no preference**
- **prefix-limit** *limit* [**log-only**] [**threshold** *percent*]
- **no prefix-limit**
- [**no**] **remove-private** {**limited**}
- [**no**] **shutdown**
- **ttl-security** *min-ttl-value*
- **no ttl-security**
- **type** {**internal** | **external**}
- **no type**
- [**no**] **updated-error-handling**
- [**no**] **vpn-apply-export**
- [**no**] **vpn-apply-import**

#### Other BGP-Related Commands

##### config

- **router** [*router-name*]
  - **autonomous-system** *as-number*
  - **no autonomous-system**
  - **router-id** *ip-address*
  - **no router-id**

## Show Commands

```

show
 — router [router-instance]
 — bgp
 — auth-keychain keychain-name
 — damping [damp-type] [detail]
 — damping [ip-prefix | prefix-length] [detail]
 — group [name] [detail]
 — neighbor [ip-address] [detail]
 — neighbor [as-number] [detail]
 — neighbor ip-address [family [type mvpn-type]] filter1 [brief]
 — neighbor ip-address [family] filter2
 — neighbor as-number [family] filter2
 — neighbor ip-address orf [filter3]
 — neighbor ip-address graceful-restart
 — next-hop [family] [ip-address] [detail]
 — paths
 — route-target
 — routes [family] [brief]
 — routes [family] prefix [detail | longer | hunt [brief]]
 — routes family [prefix] [detail | longer | hunt [brief]]
 — routes [family [type mvpn-type]] community comm-id
 — routes [family [type mvpn-type]] aspath-regex reg-ex
 — routes mvpn-ipv4 type mvpn-type {rd rd | originator-ip ip-address | source-ip ip-address | group-ip ip-address | source-as as-number} [hunt| detail]
 — routes [family [l2vpn-type]] [brief]
 — routes [family [l2vpn-type]] community comm-id
 — routes [family [l2vpn-type]] aspath-regex reg-ex
 — routes l2-vpn l2vpn-type {rd rd | [siteid site-id] | [veid veid] [offset vpls-base-offset]}
 — routes mdt-safi [rd rd] [grp-address mcast-grp-address] [brief]
 — routes ms-pw [rd rd] [aii-type2 aii-type2] [brief]
 — routes flow-ipv4
 — summary [all]
 — summary [family family] [neighbor ip-address]
 — mvpn

```

## Clear Commands

```

clear
 — router
 — bgp
 — damping [{prefix/ip-prefix-length} [neighbor ip-address]] | {group name}
 — flap-statistics [{prefix/mask [neighbor ip-address]} | [group group-name] | [regex reg-exp | policy policy-name}]
 — neighbor {ip-address | as as-number | external | all} [soft | soft-inbound]
 — neighbor {ip-address | as as-number | external | all} statistics
 — neighbor ip-address end-of-rib
 — protocol

```

## Debug Commands

```
debug
 — router
 — bgp
 — events [neighbor ip-address | group name]
 — no events
 — graceful-restart [neighbor ip-address | group name]
 — no graceful-restart
 — keepalive [neighbor ip-address | group name]
 — no keepalive
 — notification [neighbor ip-address | group name]
 — no notification
 — open [neighbor ip-address | group name]
 — no open
 — [no] outbound-route-filtering
 — packets [neighbor ip-address | group name]
 — no packets
 — route-refresh [neighbor ip-address | group name]
 — no route-refresh
 — rtm [neighbor ip-address | group name]
 — no rtm
 — socket [neighbor ip-address | group name]
 — no socket
 — timers [neighbor ip-address | group name]
 — no timers
 — update [neighbor ip-address | group name]
 — no update
```



---

## Configuration Commands

### bgp

**Syntax** [no] bgp

**Context** config>router

**Description** This command creates the BGP protocol instance and BGP configuration context. BGP is administratively enabled upon creation.

The **no** form of the command deletes the BGP protocol instance and removes all configuration parameters for the BGP instance. BGP must be **shutdown** before deleting the BGP instance. An error occurs if BGP is not **shutdown** first.

### add-paths

**Syntax** [no] add-paths

**Context** config>router>bgp  
config>router>bgp>group  
config>router>bgp>group>neighbor

**Description** This command allows adds the add-paths node to be the configured for one or more families configuration of the BGP instance, a group or a neighbor. The BGP add-paths capability allows the router to send and/or receive multiple paths per prefix to/from a peer. The add-paths command without additional parameters is equivalent to removing Add-Paths support for all address families, which causes sessions that previously negotiated the add-paths capability for one or more address families to go down and come back up without the add-paths capability.

The no form of the command (no add-paths) removes add-paths from the configuration of BGP, the group or the neighbor, causing sessions established using add-paths to go down and come back up without the add-paths capability.

**Default** no add-paths

## Configuration Commands

### ipv4

|                    |                                                                                                                                                                                                                                                                                                                                                                                                                                                                                                                                                                                                                                                                                                                                                                                                                                                                                                                                                                                                                                               |
|--------------------|-----------------------------------------------------------------------------------------------------------------------------------------------------------------------------------------------------------------------------------------------------------------------------------------------------------------------------------------------------------------------------------------------------------------------------------------------------------------------------------------------------------------------------------------------------------------------------------------------------------------------------------------------------------------------------------------------------------------------------------------------------------------------------------------------------------------------------------------------------------------------------------------------------------------------------------------------------------------------------------------------------------------------------------------------|
| <b>Syntax</b>      | <b>ipv4 send</b> <i>send-limit</i> <b>receive</b> [ <b>none</b> ]<br><b>ipv4 send</b> <i>send-limit</i><br><b>no ipv4</b>                                                                                                                                                                                                                                                                                                                                                                                                                                                                                                                                                                                                                                                                                                                                                                                                                                                                                                                     |
| <b>Context</b>     | config>router>bgp>add-paths<br>config>router>bgp>group>add-paths<br>config>router>bgp>group>neighbor>add-paths                                                                                                                                                                                                                                                                                                                                                                                                                                                                                                                                                                                                                                                                                                                                                                                                                                                                                                                                |
| <b>Description</b> | <p>This command is used to configure the add-paths capability for IPv4 routes (including labeled IPv4 routes). By default, add-paths is not enabled for IPv4 routes.</p> <p>The maximum number of paths per IPv4 prefix to send is the configured send limit, which is a mandatory parameter. The capability to receive multiple paths per prefix from a peer is configurable using the <b>receive</b> keyword, which is optional. If the <b>receive</b> keyword is not included in the command the receive capability is enabled by default. Entering the command without optional parameters negotiates the ability to both send and receive multiple paths per IPv4 prefix with each peer and configures the router to send the two best paths per prefix to each peer using the default Add-N, N=2 path selection algorithm.</p> <p>The <b>no</b> form of the command disables add-paths support for IPv4 routes, causing sessions established using add-paths for IPv4 to go down and come back up without the add-paths capability.</p> |
| <b>Default</b>     | no ipv4                                                                                                                                                                                                                                                                                                                                                                                                                                                                                                                                                                                                                                                                                                                                                                                                                                                                                                                                                                                                                                       |
| <b>Parameters</b>  | <b>send</b> <i>send-limit</i> — The maximum number of paths per IPv4 prefix that are allowed to be advertised to add-paths peers (the actual number of advertised routes may be less depending on the next-hop diversity requirement, other configuration options, route policies and/or route advertisement rules).                                                                                                                                                                                                                                                                                                                                                                                                                                                                                                                                                                                                                                                                                                                          |
|                    | <b>Values</b> 1 — 16, none                                                                                                                                                                                                                                                                                                                                                                                                                                                                                                                                                                                                                                                                                                                                                                                                                                                                                                                                                                                                                    |
|                    | <b>receive</b> — The router negotiates the add-paths receive capability for VPN-IPv4 routes with its peers                                                                                                                                                                                                                                                                                                                                                                                                                                                                                                                                                                                                                                                                                                                                                                                                                                                                                                                                    |
|                    | <b>none</b> — The router does not negotiate the Add-Paths receive capability for VPN-IPv4 routes with its peers.                                                                                                                                                                                                                                                                                                                                                                                                                                                                                                                                                                                                                                                                                                                                                                                                                                                                                                                              |

### ipv6

|                    |                                                                                                                                                          |
|--------------------|----------------------------------------------------------------------------------------------------------------------------------------------------------|
| <b>Syntax</b>      | <b>ipv6 send</b> <i>send-limit</i> <b>receive</b> [ <b>none</b> ]<br><b>ipv6 send</b> <i>send-limit</i><br><b>no ipv6</b>                                |
| <b>Context</b>     | config>router>bgp>add-paths<br>config>router>bgp>group>add-paths<br>config>router>bgp>group>neighbor>add-paths                                           |
| <b>Description</b> | This command is used to configure the add-paths capability for IPv6 routes (including 6PE routes). By default, add-paths is not enabled for IPv6 routes. |



The maximum number of paths per IPv6 prefix to send is the configured `send-limit`, which is a mandatory parameter. The capability to receive multiple paths per prefix from a peer is configurable using the `receive` keyword, which is optional. If the **receive** keyword is not included in the command the receive capability is enabled by default.

The **no** form of the command disables add-paths support for IPv6 routes, causing sessions established using add-paths for IPv6 to go down and come back up without the add-paths capability.

**Default** no ipv6

**Parameters** **send** *send-limit* — The maximum number of paths per IPv6 prefix that are allowed to be advertised to add-paths peers (the actual number of advertised routes may be less depending on the next-hop diversity requirement, other configuration options, route policies and/or route advertisement rules).

**Values** 1 — 16, none

**receive** — The router negotiates the add-paths receive capability for VPN-IPv6 routes with its peers

**none** — The router does not negotiate the Add-Paths receive capability for VPN-IPv6 routes with its peers.

## vpn-ipv4

**Syntax** **vpn-ipv4 send** *send-limit* **receive** [**none**]  
**vpn-ipv4 send** *send-limit*  
**no vpn-ipv4**

**Context** config>router>bgp>add-paths  
 config>router>bgp>group>add-paths  
 config>router>bgp>group>neighbor>add-paths

**Description** This command is used to configure the add-paths capability for VPN-IPv4 routes. By default, add-paths is not enabled for VPN-IPv4 routes.

The maximum number of paths per VPN-IPv4 NLRI to send is the configured `send-limit`, which is a mandatory parameter. The capability to receive multiple paths per prefix from a peer is configurable using the **receive** keyword, which is optional. If the **receive** keyword is not included in the command the receive capability is enabled by default.

The **no** form of the command disables add-paths support for VPN-IPv4 routes, causing sessions established using add-paths for VPN-IPv4 to go down and come back up without the add-paths capability.

**Default** no vpn-ipv4

**Parameters** *send-limit* — The maximum number of paths per VPN-IPv4 NLRI that are allowed to be advertised to add-paths peers (the actual number of advertised routes may be less depending on the next-hop diversity requirement, other configuration options, route policies and/or route advertisement rules).

**Values** 1 — 16, none

**receive** — The router negotiates the add-paths receive capability for VPN-IPv4 routes with its peers

**none** — The router does not negotiate the Add-Paths receive capability for VPN-IPv64 routes with its peers.

## Configuration Commands

### vpn-ipv6

|                    |                                                                                                                                                                                                                                                                                                                                                                                                                                                                                                                                                                                                                                                                                                                                              |
|--------------------|----------------------------------------------------------------------------------------------------------------------------------------------------------------------------------------------------------------------------------------------------------------------------------------------------------------------------------------------------------------------------------------------------------------------------------------------------------------------------------------------------------------------------------------------------------------------------------------------------------------------------------------------------------------------------------------------------------------------------------------------|
| <b>Syntax</b>      | <b>vpn-ipv6 send</b> <i>send-limit</i> <b>receive</b> [ <b>none</b> ]<br><b>vpn-ipv6 send</b> <i>send-limit</i><br><b>no vpn-ipv6</b>                                                                                                                                                                                                                                                                                                                                                                                                                                                                                                                                                                                                        |
| <b>Context</b>     | config>router>bgp>add-paths<br>config>router>bgp>group>add-paths<br>config>router>bgp>group>neighbor>add-paths                                                                                                                                                                                                                                                                                                                                                                                                                                                                                                                                                                                                                               |
| <b>Description</b> | <p>This command is used to configure the add-paths capability for VPN-IPv6 routes. By default, add-paths is not enabled for VPN-IPv6 routes.</p> <p>The maximum number of paths per VPN-IPv6 NLRI to send is the configured send-limit, which is a mandatory parameter. The capability to receive multiple paths per prefix from a peer is configurable using the <b>receive</b> keyword, which is optional. If the <b>receive</b> keyword is not included in the command the receive capability is enabled by default.</p> <p>The <b>no</b> form of the command disables add-paths support for VPN-IPv6 routes, causing sessions established using add-paths for VPN-IPv6 to go down and come back up without the add-paths capability.</p> |
| <b>Default</b>     | no vpn-ipv6                                                                                                                                                                                                                                                                                                                                                                                                                                                                                                                                                                                                                                                                                                                                  |
| <b>Parameters</b>  | <p><i>send-limit</i> — The maximum number of paths per VPN-IPv6 NLRI that are allowed to be advertised to add-paths peers (the actual number of advertised routes may be less depending on the next-hop diversity requirement, other configuration options, route policies and/or route advertisement rules).</p> <p><b>Values</b> 1 — 16, none</p> <p><b>receive</b> — The router negotiates the add-paths receive capability for VPN-IPv6 routes with its peers</p> <p><b>none</b> — The router does not negotiate the add-paths receive capability for VPN-IPv6 routes with its peers.</p>                                                                                                                                                |

### advertise-external

|                    |                                                                                                                                                                                                                                                                                                                                                                        |
|--------------------|------------------------------------------------------------------------------------------------------------------------------------------------------------------------------------------------------------------------------------------------------------------------------------------------------------------------------------------------------------------------|
| <b>Syntax</b>      | <b>[no] advertise-external</b> [ <b>ipv4</b> ] [ <b>ipv6</b> ]                                                                                                                                                                                                                                                                                                         |
| <b>Context</b>     | config>router>bgp                                                                                                                                                                                                                                                                                                                                                      |
| <b>Description</b> | <p>This command allows BGP to advertise its best external route to a destination even when its best overall route is an internal route. Entering the command (or its no form) with no address family parameters is equivalent to specifying all supported address families.</p> <p>The no form of the command disables Advertise Best External for the BGP family.</p> |
| <b>Default</b>     | no advertise-external                                                                                                                                                                                                                                                                                                                                                  |
| <b>Parameters</b>  | <p><b>ipv4</b> — Enable/disable best-external advertisement for all IPv4 (unicast and labeled-unicast) routes.</p> <p><b>ipv6</b> — Enable/disable best-external advertisement for all IPv6 (unicast and labeled-unicast) routes.</p>                                                                                                                                  |

## advertise-inactive

**Syntax** [no] advertise-inactive

**Context** config>router>bgp  
config>router>bgp>group  
config>router>bgp>group>neighbor

**Description** This command enables the advertising of inactive BGP routes to other BGP peers. By default, BGP only advertises BGP routes to other BGP peers if a given BGP route is chosen by the route table manager as the most preferred route within the system and is active in the forwarding plane. This command allows system administrators to advertise a BGP route even though it is not the most preferred route within the system for a given destination.

The **no** form of the command disables the advertising of inactive BGP routers to other BGP peers.

**Default** no advertise-inactive

## advertise-label

**Syntax** advertise-label [ipv4 [include-ldp-prefix]] [ipv6]  
no advertise-label

**Context** config>router>bgp>group>neighbor

**Description** This command configures the IPv4 transport peers to exchange IPv6 prefixes using 6PE, LDP FEC prefixes as RFC3107 labeled IPv4, as well as RFC 3107-labeled IPv4 routes.

If **ipv4** is enabled all IPv4 routes advertised to the remote BGP peer will be sent with an RFC 3107-formatted label for the destination route. If **include-ldp-fec-prefix** option is also enabled, all activated /32 LDP FEC prefixes will be sent the to remote BGP peer with an RFC 3107 formatted label.

If **ipv6** is enabled all IPv6 routes advertised to the remote BGP peer will be sent using the 6PE encapsulation.

The **no** form of the command disables any or all configured options.

The command must include one or more of the options above.

**Default** no advertise-label

**Parameters** **ipv4** — Specifies the advertisement label address family for core IPv4 routes. This keyword can be specified only for an IPv4 peer.

**include-ldp-prefix** — Specifies the inclusion of LDP FEC prefixes in the advertisement of core IPv4 routes as EFC 3107 labeled routes to the peer.

**ipv6** — Specifies the advertisement label address family to support the 6PE feature. This keyword can be specified only for an IPv6 peer.

## Configuration Commands

### aggregator-id-zero

|                    |                                                                                                                                                                                                                                                                                                                                                                                                                                                                                                                                                                                                                                                                                                                                                                                                                                                                                                                                                                                                                                                                                                                                                  |
|--------------------|--------------------------------------------------------------------------------------------------------------------------------------------------------------------------------------------------------------------------------------------------------------------------------------------------------------------------------------------------------------------------------------------------------------------------------------------------------------------------------------------------------------------------------------------------------------------------------------------------------------------------------------------------------------------------------------------------------------------------------------------------------------------------------------------------------------------------------------------------------------------------------------------------------------------------------------------------------------------------------------------------------------------------------------------------------------------------------------------------------------------------------------------------|
| <b>Syntax</b>      | <b>[no] aggregator-id-zero</b>                                                                                                                                                                                                                                                                                                                                                                                                                                                                                                                                                                                                                                                                                                                                                                                                                                                                                                                                                                                                                                                                                                                   |
| <b>Context</b>     | config>router>bgp<br>config>router>bgp>group<br>config>router>bgp>group>neighbor                                                                                                                                                                                                                                                                                                                                                                                                                                                                                                                                                                                                                                                                                                                                                                                                                                                                                                                                                                                                                                                                 |
| <b>Description</b> | <p>This command is used to set the router ID in the BGP aggregator path attribute to zero when BGP aggregates routes. This prevents different routers within an AS from creating aggregate routes that contain different AS paths.</p> <p>When BGP is aggregating routes, it adds the aggregator path attribute to the BGP update messages. By default, BGP adds the AS number and router ID to the aggregator path attribute.</p> <p>When this command is enabled, BGP adds the router ID to the aggregator path attribute. This command is used at the group level to revert to the value defined under the global level, while this command is used at the neighbor level to revert to the value defined under the group level.</p> <p>The <b>no</b> form of the command used at the global level reverts to default where BGP adds the AS number and router ID to the aggregator path attribute.</p> <p>The <b>no</b> form of the command used at the group level reverts to the value defined at the global level.</p> <p>The <b>no</b> form of the command used at the neighbor level reverts to the value defined at the group level.</p> |
| <b>Default</b>     | <b>no aggregator-id-zero</b> — BGP adds the AS number and router ID to the aggregator path attribute.                                                                                                                                                                                                                                                                                                                                                                                                                                                                                                                                                                                                                                                                                                                                                                                                                                                                                                                                                                                                                                            |

### always-compare-med

|                    |                                                                                                                                                                                                                                                                                                                                                                                                                                                                                                                                                                                                                                                                                                                                                                                                                                                                                                                                                                                                                                                                                                                 |
|--------------------|-----------------------------------------------------------------------------------------------------------------------------------------------------------------------------------------------------------------------------------------------------------------------------------------------------------------------------------------------------------------------------------------------------------------------------------------------------------------------------------------------------------------------------------------------------------------------------------------------------------------------------------------------------------------------------------------------------------------------------------------------------------------------------------------------------------------------------------------------------------------------------------------------------------------------------------------------------------------------------------------------------------------------------------------------------------------------------------------------------------------|
| <b>Syntax</b>      | <b>always-compare-med {zero   infinity}</b><br><b>no always-compare-med strict-as {zero   infinity}</b><br><b>no always-compare-med</b>                                                                                                                                                                                                                                                                                                                                                                                                                                                                                                                                                                                                                                                                                                                                                                                                                                                                                                                                                                         |
| <b>Context</b>     | config>router>bgp>best-path-selection<br>config>service>vprn>bgp>best-path-selection                                                                                                                                                                                                                                                                                                                                                                                                                                                                                                                                                                                                                                                                                                                                                                                                                                                                                                                                                                                                                            |
| <b>Description</b> | <p>This command configures the comparison of BGP routes based on the MED attribute. The default behavior of SR-OS (equivalent to the no form of the command) is to only compare two routes on the basis of MED if they have the same neighbor AS (the first non-confed AS in the received AS_PATH attribute), and they both have a MED attribute. The <b>always-compare-med</b> command without the <b>strict-as</b> keyword allows BGP paths to be compared even if they have different neighbor AS (in this case, if neither <b>zero</b> or <b>infinity</b> is part of the command, the comparison requires both paths to have a MED attribute, otherwise, <b>zero</b> or <b>infinity</b> specifies the MED value that should be inferred for paths without the attribute. When the <b>strict-as</b> keyword is present, MED is only compared between paths from the same neighbor AS, and in this case, <b>zero</b> or <b>infinity</b> is mandatory and tells BGP how to interpret paths without a MED attribute.</p> <p>The <b>no</b> form of the command removes the parameter from the configuration.</p> |
| <b>Default</b>     | <b>no always-compare-med</b> — Only compare MEDs of routes that have the same peer AS.                                                                                                                                                                                                                                                                                                                                                                                                                                                                                                                                                                                                                                                                                                                                                                                                                                                                                                                                                                                                                          |
| <b>Parameters</b>  | <b>zero</b> — Specifies that for routes learned without a MED attribute that a zero (0) value is used in the MED comparison. The routes with the lowest metric are the most preferred.                                                                                                                                                                                                                                                                                                                                                                                                                                                                                                                                                                                                                                                                                                                                                                                                                                                                                                                          |

**infinity** — Specifies for routes learned without a MED attribute that a value of infinity ( $2^{32}-1$ ) is used in the MED comparison. This in effect makes these routes the least desirable.

**strict-as** — Specifies BGP paths to be compared even with different neighbor AS.

## as-path-ignore

**Syntax** **as-path-ignore [ipv4] [vpn-ipv4] [ipv6] [vpn-ipv6] [mcast-ipv4] [mvpn-ipv4] [l2-vpn]**  
**no as-path-ignore**

**Context** config>router>bgp>best-path-selection  
 config>service>vpn>bgp>best-path-selection

**Description** This command determines whether the AS path is used to determine the best BGP route. If this option is present, the AS paths of incoming routes are not used in the route selection process. The **no** form of the command removes the parameter from the configuration.

**Default** **no as-path-ignore**

**Parameters** **ipv4** — Specifies that the AS-path length will be ignored for all IPv4 routes.  
**vpn-ipv4** — Specifies that the lengthAS-path will be ignored for all IPv4 VPRN routes.  
**ipv6** — Specifies that the AS-path length will be ignored for all IPv6 routes.  
**vpn-ipv6** — Specifies that the AS-path length will be ignored for all IPv6 VPRN routes.  
**mcast-ipv4** — Specifies that the AS-path length will be ignored for all IPv4 multicast routes.  
**mvpn-ipv4** — Specifies that the AS-path length will be ignored for all mVPN IPv4 multicast routes.  
**l2-vpn** — The AS-path length will be ignored for all L2-VPN NLRIs.

## auth-keychain

**Syntax** **auth-keychain *name***

**Context** config>router>bgp  
 config>router>bgp>group  
 config>router>bgp>group>neighbor

**Description** This command configures a TCP authentication keychain to use for the session. The keychain allows the rollover of authentication keys during the lifetime of a session.

**Default** no auth-keychain

**Parameters** *name* — Specifies the name of the keychain, up to 32 characters, to use for the specified TCP session or sessions.

### authentication-key

|                    |                                                                                                                                                                                                                                                                                                                                                                                                                                                                                                                                                                                                                                                                                                                                                                                                                                                                                                                                                                                                                                                                                                                     |
|--------------------|---------------------------------------------------------------------------------------------------------------------------------------------------------------------------------------------------------------------------------------------------------------------------------------------------------------------------------------------------------------------------------------------------------------------------------------------------------------------------------------------------------------------------------------------------------------------------------------------------------------------------------------------------------------------------------------------------------------------------------------------------------------------------------------------------------------------------------------------------------------------------------------------------------------------------------------------------------------------------------------------------------------------------------------------------------------------------------------------------------------------|
| <b>Syntax</b>      | <b>authentication-key</b> [ <i>authentication-key</i>   <i>hash-key</i> ] [ <b>hash</b>   <b>hash2</b> ]<br><b>no authentication-key</b>                                                                                                                                                                                                                                                                                                                                                                                                                                                                                                                                                                                                                                                                                                                                                                                                                                                                                                                                                                            |
| <b>Context</b>     | config>router>bgp<br>config>router>bgp>group<br>config>router>bgp>group>neighbor                                                                                                                                                                                                                                                                                                                                                                                                                                                                                                                                                                                                                                                                                                                                                                                                                                                                                                                                                                                                                                    |
| <b>Description</b> | <p>This command configures the BGP authentication key.</p> <p>Authentication is performed between neighboring routers before setting up the BGP session by verifying the password. Authentication is performed using the MD-5 message based digest.</p> <p>The authentication <i>key</i> can be any combination of ASCII characters up to 255 characters long.</p> <p>The <b>no</b> form of the command reverts to the default value.</p>                                                                                                                                                                                                                                                                                                                                                                                                                                                                                                                                                                                                                                                                           |
| <b>Default</b>     | MD5 Authentication is disabled by default.                                                                                                                                                                                                                                                                                                                                                                                                                                                                                                                                                                                                                                                                                                                                                                                                                                                                                                                                                                                                                                                                          |
| <b>Parameters</b>  | <p><i>authentication-key</i> — The authentication key. The key can be any combination of ASCII characters up to 255 characters in length (unencrypted). If spaces are used in the string, enclose the entire string in quotation marks (“ ”).</p> <p><i>hash-key</i> — The hash key. The key can be any combination of ASCII characters up to 342 characters in length (encrypted). If spaces are used in the string, enclose the entire string in quotation marks (“ ”).</p> <p>This is useful when a user must configure the parameter, but, for security purposes, the actual unencrypted key value is not provided.</p> <p><b>hash</b> — Specifies the key is entered in an encrypted form. If the <b>hash</b> parameter is not used, the key is assumed to be in a non-encrypted, clear text form. For security, all keys are stored in encrypted form in the configuration file with the <b>hash</b> parameter specified.</p> <p><b>hash2</b> — Specifies the key is entered in a more complex encrypted form. If the <b>hash2</b> parameter is not used, the less encrypted <b>hash</b> form is assumed.</p> |

### backup-path

|                    |                                                                                                                                                                                                                                                                                                                                                                                                                                                                                                                                                                                                                                                                                                                                         |
|--------------------|-----------------------------------------------------------------------------------------------------------------------------------------------------------------------------------------------------------------------------------------------------------------------------------------------------------------------------------------------------------------------------------------------------------------------------------------------------------------------------------------------------------------------------------------------------------------------------------------------------------------------------------------------------------------------------------------------------------------------------------------|
| <b>Syntax</b>      | <b>backup-path</b> [ <b>ipv4</b> ] [ <b>ipv6</b> ] [ <b>vpn-ipv4</b> ] [ <b>vpn-ipv6</b> ]<br><b>no backup-path</b> [ <b>ipv4</b> ] [ <b>ipv6</b> ]                                                                                                                                                                                                                                                                                                                                                                                                                                                                                                                                                                                     |
| <b>Context</b>     | config>router>bgp<br>config>service>vpn>bgp                                                                                                                                                                                                                                                                                                                                                                                                                                                                                                                                                                                                                                                                                             |
| <b>Description</b> | <p>This command enables the computation and use of a backup path for IPv4 and/or IPv6 BGP routes belonging to the base router or a particular VPRN. Multiple paths must be received for a route in order to take advantage of this feature. When a route has a backup path and the last of its primary paths (the equal-cost best paths selected by the multipath algorithm) becomes unreachable, traffic matching the route is quickly diverted to the backup path. When many routes share the same set of primary paths and the same backup path, the time to failover traffic to the backup path is independent of the number of routes.</p> <p>By default, IPv4 and IPv6 routes do not have a backup path installed in the FIB.</p> |

|                   |                                                                                                                                                                                                                                                                                                                                                                                                                                                                                                                                                                                                                                                                                                                                                                                                                                                                                                                                                                       |
|-------------------|-----------------------------------------------------------------------------------------------------------------------------------------------------------------------------------------------------------------------------------------------------------------------------------------------------------------------------------------------------------------------------------------------------------------------------------------------------------------------------------------------------------------------------------------------------------------------------------------------------------------------------------------------------------------------------------------------------------------------------------------------------------------------------------------------------------------------------------------------------------------------------------------------------------------------------------------------------------------------|
| <b>Default</b>    | no backup-path                                                                                                                                                                                                                                                                                                                                                                                                                                                                                                                                                                                                                                                                                                                                                                                                                                                                                                                                                        |
| <b>Parameters</b> | <p><b>ipv4</b> — Enables the use of a backup path for IPv4 BGP routes (excluding labeled IPv4 routes and VPN-IPv4 routes); disable the use of a backup path for IPv4 BGP routes when present in the no form of the command (as in no backup-path ipv4)</p> <p><b>ipv6</b> — Enables the use of a backup path for IPv6 BGP routes (excluding labeled IPv6 routes and VPN-IPv6 routes); disable the use of a backup path for IPv6 BGP routes when present in the no form of the command (as in no backup-path ipv6)</p> <p><b>vpn-ipv4</b> — Enables the use of a backup path for vpn-ipv4 BGP routes; disables the use of a backup path for vpn-ipv4 BGP routes when present in the no form of the command (as in no backup-path vpn-ipv4)</p> <p><b>vpn-ipv6</b> — Enables the use of a backup path for vpn-ipv6 BGP routes; disables the use of a backup path for vpn-ipv6 BGP routes when present in the no form of the command (as in no backup-path vpn-ipv6)</p> |

## best-path-selection

|                    |                                                    |
|--------------------|----------------------------------------------------|
| <b>Syntax</b>      | <b>best-path-selection</b>                         |
| <b>Context</b>     | config>router>bgp                                  |
| <b>Description</b> | This command enables path selection configuration. |

## bfd-enable

|                    |                                                                                                                                                                                                                                                                                                                                                                                                                                                                                                    |
|--------------------|----------------------------------------------------------------------------------------------------------------------------------------------------------------------------------------------------------------------------------------------------------------------------------------------------------------------------------------------------------------------------------------------------------------------------------------------------------------------------------------------------|
| <b>Syntax</b>      | <b>[no] bfd-enable</b>                                                                                                                                                                                                                                                                                                                                                                                                                                                                             |
| <b>Context</b>     | config>router>bgp<br>config>router>bgp>group<br>config>router>bgp>group>neighbor                                                                                                                                                                                                                                                                                                                                                                                                                   |
| <b>Description</b> | <p>This command enables the use of bi-directional forwarding (BFD) to control the state of the associated protocol interface. By enabling BFD on a given protocol interface, the state of the protocol interface is tied to the state of the BFD session between the local node and the remote node. The parameters used for the BFD are set via the BFD command under the IP interface.</p> <p>The <b>no</b> form of this command removes BFD from the associated IGP/BGP protocol adjacency.</p> |
| <b>Default</b>     | no bfd-enable                                                                                                                                                                                                                                                                                                                                                                                                                                                                                      |

## Configuration Commands

### cluster

|                    |                                                                                                                                                                                                                                                                                                                                                                                                                                                                                                                                                                                                                                                                                                                                                                                                                                                                                                                                                                                                                                                                                                              |
|--------------------|--------------------------------------------------------------------------------------------------------------------------------------------------------------------------------------------------------------------------------------------------------------------------------------------------------------------------------------------------------------------------------------------------------------------------------------------------------------------------------------------------------------------------------------------------------------------------------------------------------------------------------------------------------------------------------------------------------------------------------------------------------------------------------------------------------------------------------------------------------------------------------------------------------------------------------------------------------------------------------------------------------------------------------------------------------------------------------------------------------------|
| <b>Syntax</b>      | <b>cluster</b> <i>cluster-id</i><br><b>no cluster</b>                                                                                                                                                                                                                                                                                                                                                                                                                                                                                                                                                                                                                                                                                                                                                                                                                                                                                                                                                                                                                                                        |
| <b>Context</b>     | config>router>bgp<br>config>router>bgp>group<br>config>router>bgp>group>neighbor                                                                                                                                                                                                                                                                                                                                                                                                                                                                                                                                                                                                                                                                                                                                                                                                                                                                                                                                                                                                                             |
| <b>Description</b> | <p>This command configures the cluster ID for a route reflector server.</p> <p>Route reflectors are used to reduce the number of IBGP sessions required within an AS. Normally, all BGP speakers within an AS must have a BGP peering with every other BGP speaker in an AS. A route reflector and its clients form a cluster. Peers that are not part of the cluster are considered to be non-clients.</p> <p>When a route reflector receives a route, first it must select the best path from all the paths received. If the route was received from a non-client peer, then the route reflector sends the route to all clients in the cluster. If the route came from a client peer, the route reflector sends the route to all non-client peers and to all client peers except the originator.</p> <p>For redundancy, a cluster can have multiple route reflectors.</p> <p>Confederations can also be used to remove the full IBGP mesh requirement within an AS.</p> <p>The <b>no</b> form of the command deletes the cluster ID and effectively disables the Route Reflection for the given group.</p> |
| <b>Default</b>     | <b>no cluster</b> — No cluster ID is defined.                                                                                                                                                                                                                                                                                                                                                                                                                                                                                                                                                                                                                                                                                                                                                                                                                                                                                                                                                                                                                                                                |
| <b>Parameters</b>  | <i>cluster-id</i> — The route reflector cluster ID is expressed in dot decimal notation.<br><b>Values</b> Any 32 bit number in dot decimal notation. (0.0.0.1 — 255.255.255.255)                                                                                                                                                                                                                                                                                                                                                                                                                                                                                                                                                                                                                                                                                                                                                                                                                                                                                                                             |

### confederation

|                    |                                                                                                                                                                                                                                                                                                                                                                                                                                                                                                                                                                                              |
|--------------------|----------------------------------------------------------------------------------------------------------------------------------------------------------------------------------------------------------------------------------------------------------------------------------------------------------------------------------------------------------------------------------------------------------------------------------------------------------------------------------------------------------------------------------------------------------------------------------------------|
| <b>Syntax</b>      | <b>confederation</b> <i>confed-as-num</i> <b>members</b> <i>member-as-num</i><br><b>no confederation</b> <i>confed-as-num</i> [ <b>members</b> <i>member-as-num</i> ]                                                                                                                                                                                                                                                                                                                                                                                                                        |
| <b>Context</b>     | config>router                                                                                                                                                                                                                                                                                                                                                                                                                                                                                                                                                                                |
| <b>Description</b> | <p>This command creates confederation autonomous systems within an AS.</p> <p>This technique is used to reduce the number of IBGP sessions required within an AS. Route reflection is the other technique that is commonly deployed to reduce the number of IBGP sessions.</p> <p>The <b>no</b> form of the command deletes the specified member AS from the confederation.</p> <p>When members are not specified in the <b>no</b> statement, the entire list is removed and confederations is disabled.</p> <p>When the last member of the list is removed, confederations is disabled.</p> |
| <b>Default</b>     | <b>no confederation</b> — No confederations are defined.                                                                                                                                                                                                                                                                                                                                                                                                                                                                                                                                     |



**Parameters** *confed-as-num* — The confederation AS number expressed as a decimal integer.

**Values** 1 — 65535

**members** *member-as-num* — The AS number(s) of members that are part of the confederation expressed as a decimal integer. Configure up to 15 members per *confed-as-num*.

## connect-retry

**Syntax** **connect-retry** *seconds*  
**no connect-retry**

**Context** config>router>bgp  
config>router>bgp>group  
config>router>bgp>group>neighbor

**Description** This command configures the BGP connect retry timer value in seconds.

When this timer expires, BGP tries to reconnect to the configured peer. This configuration parameter can be set at three levels: global level (applies to all peers), peer-group level (applies to all peers in group) or neighbor level (only applies to specified peer). The most specific value is used.

The **no** form of the command used at the global level reverts to the default value.

The **no** form of the command used at the group level reverts to the value defined at the global level.

The **no** form of the command used at the neighbor level reverts to the value defined at the group level.

**Default** 120 *seconds*

**Parameters** *seconds* — The BGP Connect Retry timer value in seconds expressed as a decimal integer.

**Values** 1 — 65535

## damping

**Syntax** [**no**] **damping**

**Context** config>router>bgp  
config>router>bgp>group  
config>router>bgp>group>neighbor

**Description** This command enables BGP route damping for learned routes which are defined within the route policy. Use damping to reduce the number of update messages sent between BGP peers and reduce the load on peers without affecting the route convergence time for stable routes. Damping parameters are set via route policy definition.

The **no** form of the command used at the global level reverts route damping.

The **no** form of the command used at the group level reverts to the value defined at the global level.

The **no** form of the command used at the neighbor level reverts to the value defined at the group level.

When damping is enabled and the route policy does not specify a damping profile, the default damping profile is used. This profile is always present and consists of the following parameters:

## Configuration Commands

|                     |            |
|---------------------|------------|
| Half-life:          | 15 minutes |
| Max-suppress:       | 60 minutes |
| Suppress-threshold: | 3000       |
| Reuse-threshold:    | 750        |

**Default** **no damping** — Learned route damping is disabled.

### default-route-target

**Syntax** **default-route-target**  
**no default-route-target**

**Context** config>router>bgp>group  
config>router>bgp>group>neighbor

**Description** This command originates the default RTC route (zero prefix length) towards the selected peers.

**Default** No default RTC routes are advertised by the router.

### description

**Syntax** **description** *description-string*  
**no description**

**Context** config>router>bgp  
config>router>bgp>group  
config>router>bgp>group>neighbor

**Description** This command creates a text description stored in the configuration file for a configuration context. The **no** form of the command removes the description string from the context.

**Default** No description is associated with the configuration context.

**Parameters** *string* — The description character string. Allowed values are any string up to 80 characters long composed of printable, 7-bit ASCII characters. If the string contains special characters (#, \$, spaces, etc.), the entire string must be enclosed within double quotes.

### disable-4byte-asn

**Syntax** [**no**] **disable-4byte-asn**

**Context** config>router>bgp  
config>router>bgp>group  
config>router>bgp>group>neighbor

**Description** This command disables the use of 4-byte ASNs. It can be configured at all 3 level of the hierarchy so it can be specified down to the per peer basis.

If this command is enabled 4-byte ASN support should not be negotiated with the associated remote peer(s). The **no** form of the command resets the behavior to the default which is to enable the use of 4-byte ASN.

## disable-capability-negotiation

**Syntax** [no] **disable-capability-negotiation**

**Context** config>router>bgp>group  
config>router>bgp>group>neighbor

**Description** This command disables the exchange of capabilities. When command is enabled and after the peering is flapped, any new capabilities are not negotiated and will strictly support IPv4 routing exchanges with that peer.

The **no** form of the command removes this command from the configuration and restores the normal behavior.

**Default** no disable-capability-negotiation

## disable-client-reflect

**Syntax** [no] **disable-client-reflect**

**Context** config>router>bgp  
config>router>bgp>group  
config>router>bgp>group>neighbor

**Description** This command disables the reflection of routes by the route reflector to the clients in a specific group or neighbor.

This only disables the reflection of routes from other client peers. Routes learned from non-client peers are still reflected to all clients.

The **no** form re-enables client reflection of routes.

**Default** **no disable-client-reflect** — Client routes are reflected to all client peers.

## disable-communities

**Syntax** **disable-communities** [standard] [extended]  
**no disable-communities**

**Context** config>router>bgp  
config>router>bgp>group  
config>router>bgp>group>neighbor

**Description** This command configures BGP to disable sending communities.

## Configuration Commands

- Parameters**    **standard** — Specifies standard communities that existed before VPRNs or 2547.  
                  **extended** — Specifies BGP communities used were expanded after the concept of 2547 was introduced, to include handling the VRF target.

### disable-fast-external-failover

- Syntax**        **[no] disable-fast-external-failover**
- Context**        config>router>bgp  
                  config>router>bgp>group  
                  config>router>bgp>group>neighbor
- Description**    This command configures BGP fast external failover.

### enable-inter-as-vpn

- Syntax**        **[no] enable-inter-as-vpn**
- Context**        config>router>bgp
- Description**    This command specifies whether VPNs can exchange routes across autonomous system boundaries, providing model B connectivity.
- The **no** form of the command disallows ASBRs to advertise VPRN routes to their peers in other autonomous systems.
- Default**        no enable-inter-as-vpn

### enable-peer-tracking

- Syntax**        **[no] enable-peer-tracking**
- Context**        config>router>bgp  
                  config>router>bgp>group  
                  config>router>bgp>group>neighbor
- Description**    This command enables BGP peer tracking. BGP peer tracking allows a BGP peer to be dropped immediately if the route used to resolve the BGP peer address is removed from the IP routing table and there is no alternative available. The BGP peer will not wait for the holdtimer to expire; therefore, the BGP reconvergence process is accelerated.
- The **no** form of the command disables peer tracking.
- Default**        no enable-peer-tracking

## export

|                    |                                                                                                                                                                                                                                                                                                                                                                                                                                                                                                                                                                                                                                                                                                                                                                                                                                                                                                                                                                                              |
|--------------------|----------------------------------------------------------------------------------------------------------------------------------------------------------------------------------------------------------------------------------------------------------------------------------------------------------------------------------------------------------------------------------------------------------------------------------------------------------------------------------------------------------------------------------------------------------------------------------------------------------------------------------------------------------------------------------------------------------------------------------------------------------------------------------------------------------------------------------------------------------------------------------------------------------------------------------------------------------------------------------------------|
| <b>Syntax</b>      | <b>export</b> <i>policy-name</i> [ <i>policy-name...</i> ]<br><b>no export</b> [ <i>policy-name</i> ]                                                                                                                                                                                                                                                                                                                                                                                                                                                                                                                                                                                                                                                                                                                                                                                                                                                                                        |
| <b>Context</b>     | config>router>bgp<br>config>router>bgp>group<br>config>router>bgp>group>neighbor                                                                                                                                                                                                                                                                                                                                                                                                                                                                                                                                                                                                                                                                                                                                                                                                                                                                                                             |
| <b>Description</b> | <p>This command specifies the export route policy used to determine which routes are advertised to peers. This configuration parameter can be set at three levels: global level (applies to all peers), group level (applies to all peers in peer-group) or neighbor level (only applies to specified peer). The most specific level is used.</p> <p>When multiple policy names are specified, the policies are evaluated in the order they are specified. A maximum of five (5) policy names can be configured. The first policy that matches is applied.</p> <p>When multiple export commands are issued, the last command entered overrides the previous command.</p> <p>When no export policies are specified, BGP routes are advertised and non-BGP routes are not advertised by default.</p> <p>The <b>no</b> form of the command removes the policy association with the BGP instance. To remove association of all policies, use the <b>no export</b> command without arguments.</p> |
| <b>Default</b>     | <b>no export</b> — No export policy is specified. BGP routes are advertised and non-BGP routes are not advertised.                                                                                                                                                                                                                                                                                                                                                                                                                                                                                                                                                                                                                                                                                                                                                                                                                                                                           |
| <b>Parameters</b>  | <i>policy-name</i> — The route policy name. Allowed values are any string up to 32 characters long composed of printable, 7-bit ASCII characters. If the string contains special characters (#, \$, spaces, etc.), the entire string must be enclosed within double quotes. Route policies are configured in the <b>config&gt;router&gt;policy-options</b> context.                                                                                                                                                                                                                                                                                                                                                                                                                                                                                                                                                                                                                          |

## family

|                    |                                                                                                                                                                                                                                                                                                                                                                                                                                                     |
|--------------------|-----------------------------------------------------------------------------------------------------------------------------------------------------------------------------------------------------------------------------------------------------------------------------------------------------------------------------------------------------------------------------------------------------------------------------------------------------|
| <b>Syntax</b>      | <b>family</b> [ <i>ipv4</i> ] [ <i>vpn-ipv4</i> ] [ <i>ipv6</i> ] [ <i>mcast-ipv4</i> ] [ <i>l2-vpn</i> ] [ <i>mvpn-ipv4</i> ] [ <i>flow-ipv4</i> ] [ <i>mdt-safi</i> ] [ <i>ms-pw</i> ] [ <i>route-target</i> ]<br><b>no family</b>                                                                                                                                                                                                                |
| <b>Context</b>     | config>router>bgp<br>config>router>bgp>group<br>config>router>bgp>group>neighbor                                                                                                                                                                                                                                                                                                                                                                    |
| <b>Description</b> | <p>This command specifies the address family or families to be supported over BGP peerings in the base router. This command is additive so issuing the <b>family</b> command adds the specified address family to the list.</p> <p>The <b>no</b> form of the command removes the specified address family from the associated BGP peerings. If an address family is not specified, then reset the supported address family back to the default.</p> |
| <b>Default</b>     | <b>ipv4</b>                                                                                                                                                                                                                                                                                                                                                                                                                                         |
| <b>Parameters</b>  | <b>ipv4</b> — Provisions support for IPv4 routing information.                                                                                                                                                                                                                                                                                                                                                                                      |

## Configuration Commands

**vpn-ipv4** — Exchanges IPv4 VPN routing information.

**ipv6** — Exchanges IPv6 routing information.

**mcast-ipv4** — Exchanges multicast IPv4 routing information.

**l2-vpn** — Exchanges Layer 2 VPN information.

**mvpn-ipv4** — Exchanges Multicast VPN related information.

**flow-ipv4** — Exchanges IPv4 flowspec routes belonging to AFI 1 and SAFI 133.

**mdt-safi** — Exchanges Multicast VPN information using MDT-SAFI address family

**ms-pw** — Exchanges dynamic MS-PW related information.

**route-target** — Exchanges RT constraint routes for VPN route filtering.

### flowspec-validate

**Syntax**    **flowspec-validate**  
              **no flowspec-validate**

**Context**    config>router>bgp  
              config>router>bgp>group  
              config>router>bgp>group>neighbor

**Description**    This command enables/disables validation of received flowspec routes. A flow route with a destination prefix subcomponent received from a particular peer is considered valid if and only if that peer also advertised the best unicast route to the destination prefix and any of its more-specific components. Also, when a flow route is received from an EBGW peer the leftmost AS number in the AS\_PATH attribute must equal the peer's AS number. If validation is enabled and a flowspec route is not valid it is not eligible for import into the RIB, it is not used for filtering, a log/trap is generated and it is not propagated to other flowspec peers.

The **no** form of the command disables the validation procedure.

**Default**    **no flowspec-validate**

### route-target-list

**Syntax**    **route-target-list** *comm-id* [*comm-id* ..[up to 15 max]]  
              **no route-target-list** [*comm-id*]

**Context**    config>router>bgp

**Description**    This command specifies the route target(s) to be accepted and advertised from/to route reflector clients. If the **route-target-list** is a non-null list, only routes with one or more of the given route targets are accepted or advertised to route reflector clients.

This command is only applicable if the router is a route-reflector server. This parameter has no affect on non-route-reflector clients.

If the **route-target-list** is assigned at the global level, then the list applies to all route-reflector clients connected to the system.

The **no** form of the command with a specified route target community, removes the specified community from the **route-target-list**. The **no** form of the command entered *without* a route target community removes all communities from the list.

**Default** **no route-target-list**

**Parameters** *comm-id* — Specifies the route target community in the form <0..65535>:<0..65535>

## updated-error-handling

**Syntax** **[no] updated-error-handling**

**Context** config>router>bgp>group  
config>router>bgp>group>neighbor

**Description** This command controls whether SROS utilizes the new neighbor-complete bit when processing optional transitive path attributes and advertising them to the associated BGP neighbor.

This command also control if SROS utilizes the error handling mechanism for optional-transitive path attributes.

**Default** no updated-error-handling

## vpn-apply-export

**Syntax** **[no] vpn-apply-export**

**Context** config>router>bgp  
config>router>bgp>group  
config>router>bgp>group>neighbor

**Description** This command causes the base instance BGP export route policies to be applied to VPN-IPv4 routes.

The **no** form of the command disables the application of the base instance BGP route policies to VPN-IPv4 routes.

**Default** no vpn-apply-export

## Configuration Commands

### vpn-apply-import

|                    |                                                                                                                                                                                                                                        |
|--------------------|----------------------------------------------------------------------------------------------------------------------------------------------------------------------------------------------------------------------------------------|
| <b>Syntax</b>      | <b>[no] vpn-apply-import</b>                                                                                                                                                                                                           |
| <b>Context</b>     | config>router>bgp<br>config>router>bgp>group<br>config>router>bgp>group>neighbor                                                                                                                                                       |
| <b>Description</b> | This command causes the base instance BGP import route policies to be applied to VPN-IPv4 routes.<br><br>The <b>no</b> form of the command disables the application of the base instance BGP import route policies to VPN-IPv4 routes. |
| <b>Default</b>     | <b>no vpn-apply-import</b>                                                                                                                                                                                                             |

### graceful-restart

|                    |                                                                                                                                                                                                                                                                                                                                                                                                                                                                                                                                     |
|--------------------|-------------------------------------------------------------------------------------------------------------------------------------------------------------------------------------------------------------------------------------------------------------------------------------------------------------------------------------------------------------------------------------------------------------------------------------------------------------------------------------------------------------------------------------|
| <b>Syntax</b>      | <b>[no] graceful-restart</b>                                                                                                                                                                                                                                                                                                                                                                                                                                                                                                        |
| <b>Context</b>     | config>router>bgp<br>config>router>bgp>group<br>config>router>bgp>group>neighbor                                                                                                                                                                                                                                                                                                                                                                                                                                                    |
| <b>Description</b> | This command enables graceful-restart for BGP. When the control plane of a GR-capable router fails, the neighboring routers (GR helpers) temporarily preserve neighbor information, so packets continue to be forwarded through the failed GR router using the last known routes. The helper state remains until the peer completes its restart or exits if the GR timer value is exceeded.<br><br>The <b>no</b> form of the command disables graceful restart and removes all graceful restart configurations in the BGP instance. |
| <b>Default</b>     | no graceful-restart                                                                                                                                                                                                                                                                                                                                                                                                                                                                                                                 |

### stale-routes-time

|                    |                                                                                                                                                                                                                                                       |
|--------------------|-------------------------------------------------------------------------------------------------------------------------------------------------------------------------------------------------------------------------------------------------------|
| <b>Syntax</b>      | <b>stale-routes-time <i>time</i></b><br><b>no stale-routes-time</b>                                                                                                                                                                                   |
| <b>Context</b>     | config>router>bgp>graceful-restart<br>config>router>bgp>group>graceful-restart<br>config>router>bgp>group>neighbor>graceful-restart                                                                                                                   |
| <b>Description</b> | This command configures the maximum amount of time in seconds that stale routes should be maintained after a graceful restart is initiated.<br><br>The <b>no</b> form of the command resets the stale routes time back to the default of 360 seconds. |
| <b>Default</b>     | no restart time                                                                                                                                                                                                                                       |



**Parameters** *time* — Specify the amount of time that stale routes should be maintained after a graceful restart is initiated.  
**Values** 1 — 3600 seconds

## group

**Syntax** **[no] group name**

**Context** config>router>bgp

**Description** This command creates a context to configure a BGP peer group.  
 The **no** form of the command deletes the specified peer group and all configurations associated with the peer group. The group must be **shutdown** before it can be deleted.

**Default** No peer groups are defined.

**Parameters** *name* — The peer group name. Allowed values are any string up to 32 characters long composed of printable, 7-bit ASCII characters. If the string contains special characters (#, \$, spaces, etc.), the entire string must be enclosed within double quotes.

## hold-time

**Syntax** **hold-time seconds [min seconds2]**  
**no hold-time**

**Context** config>router>bgp  
 config>router>bgp>group  
 config>router>bgp>group>neighbor

**Description** This command configures the BGP hold time, expressed in seconds.  
 The BGP hold time specifies the maximum time BGP waits between successive messages (either keepalive or update) from its peer, before closing the connection. This configuration parameter can be set at three levels: global level (applies to all peers), group level (applies to all peers in group) or neighbor level (only applies to specified peer). The most specific value is used.

Even though the implementation allows setting the **keepalive** time separately, the configured **keepalive** timer is overridden by the **hold-time** value under the following circumstances:

1. If the specified hold-time is less than the configured **keepalive** time, then the operational **keepalive** time is set to a third of the **hold-time**; the configured **keepalive** time is not changed.
2. If the **hold-time** is set to zero, then the operational value of the **keepalive** time is set to zero; the configured **keepalive** time is not changed. This means that the connection with the peer is up permanently and no **keepalive** packets are sent to the peer.

The **no** form of the command used at the global level reverts to the default value.

The **no** form of the command used at the group level reverts to the value defined at the global level.

The **no** form of the command used at the neighbor level reverts to the value defined at the group level.

**Default** 90 seconds

## Configuration Commands

- Parameters**    *seconds* — The hold-time, in seconds, expressed as a decimal integer. A value of 0 indicates the connection to the peer is up permanently.
- Values**     0, 3 — 65535
- seconds2* — The minimum hold-time that will be accepted for the session. If the peer proposes a hold-time lower than this value, the session attempt will be rejected.

### ibgp-multipath

- Syntax**     **[no] ibgp-multipath**
- Context**     config>router>bgp
- Description**    This command enables IBGP multipath load balancing when adding BGP routes to the route table if the route resolving the BGP nexthop offers multiple nexthops.
- The **no** form of the command disables the IBGP multipath load balancing feature.
- Default**     **no ibgp-multipath**

### ignore-nh-metric

- Syntax**     **ignore-nh-metric**  
                  **no ignore-nh-metric**
- Context**     config>router>bgp>best-path-selection  
                  config>service>vprn  
                  config>service>vprn>bgp>best-path-selection
- Description**    This command instructs BGP to disregard the resolved distance to the BGP next-hop in its decision process for selecting the best route to a destination. When configured in the config>router>bgp>best-path-selection context, this command applies to the comparison of two BGP routes with the same NLRI learned from base router BGP peers. When configured in the config>service>vprn context, this command applies to the comparison of two BGP-VPN routes for the same IP prefix imported into the VPRN from the base router BGP instance. When configured in the config>service>vprn>bgp>best-path-selection context, this command applies to the comparison of two BGP routes for the same IP prefix learned from VPRN BGP peers.
- The no form of the command (no ignore-nh-metric) restores the default behavior whereby BGP factors distance to the next-hop into its decision process.
- Default**     **no ignore-nh-metric**

## ignore-router-id

|                    |                                                                                                                                                                                                                                                                                                                                                                                                                                                                                                 |
|--------------------|-------------------------------------------------------------------------------------------------------------------------------------------------------------------------------------------------------------------------------------------------------------------------------------------------------------------------------------------------------------------------------------------------------------------------------------------------------------------------------------------------|
| <b>Syntax</b>      | <b>ignore-router-id</b><br><b>no ignore-router-id</b>                                                                                                                                                                                                                                                                                                                                                                                                                                           |
| <b>Context</b>     | config>router>bgp>best-path-selection<br>config>service>vprn>bgp>best-path-selection                                                                                                                                                                                                                                                                                                                                                                                                            |
| <b>Description</b> | When the ignore-router-id command is present and the current best path to a destination was learned from EBGP peer X with BGP identifier x and a new path is received from EBGP peer Y with BGP identifier y the best path remains unchanged if the new path is equivalent to the current best path up to the BGP identifier comparison – even if y is less than x. The no form of the command restores the default behavior of selecting the route with the lowest BGP identifier (y) as best. |
| <b>Default</b>     | <b>no ignore-router-id</b>                                                                                                                                                                                                                                                                                                                                                                                                                                                                      |

## igp-shortcut

|                    |                                                                                                                                                                                                                                                                                                                                                                                                                                                                                                                                                                                                                                                                                                                                                                                                                                                                                                                                                                                                                                                                                                                                                                                                                                                                                                                                                                                                                                                                                                  |
|--------------------|--------------------------------------------------------------------------------------------------------------------------------------------------------------------------------------------------------------------------------------------------------------------------------------------------------------------------------------------------------------------------------------------------------------------------------------------------------------------------------------------------------------------------------------------------------------------------------------------------------------------------------------------------------------------------------------------------------------------------------------------------------------------------------------------------------------------------------------------------------------------------------------------------------------------------------------------------------------------------------------------------------------------------------------------------------------------------------------------------------------------------------------------------------------------------------------------------------------------------------------------------------------------------------------------------------------------------------------------------------------------------------------------------------------------------------------------------------------------------------------------------|
| <b>Syntax</b>      | <b>igp-shortcut [ldp   rsvp-te   mpls] [disallow-igp]</b><br><b>no igp-shortcut</b>                                                                                                                                                                                                                                                                                                                                                                                                                                                                                                                                                                                                                                                                                                                                                                                                                                                                                                                                                                                                                                                                                                                                                                                                                                                                                                                                                                                                              |
| <b>Context</b>     | config>router>bgp                                                                                                                                                                                                                                                                                                                                                                                                                                                                                                                                                                                                                                                                                                                                                                                                                                                                                                                                                                                                                                                                                                                                                                                                                                                                                                                                                                                                                                                                                |
| <b>Description</b> | <p>This command enables the use of LDP tunnels, RSVP tunnels, or both, to resolve paths to BGP next-hops.</p> <p>The <b>ldp</b> option instructs BGP to search for an LDP LSP with a FEC prefix corresponding to the /32 address of the BGP next-hop. This deprecates the existing ldp-shortcut command under BGP. Support for the older command will be provided over a number of releases to allow old config files to execute.</p> <p>The <b>rsvp-te</b> option instructs BGP to search for the best metric RSVP LSP to the /32 address of the BGP next-hop. This address can correspond to the system interface or to another loopback used by the BGP instance on the remote node as its router-id. The LSP metric is provided by MPLS in the tunnel table.</p> <p>The <b>mpls</b> option instructs BGP to first attempt to resolve the BGP next-hop to an RSVP LSP. If no RSVP LSP exists or if the existing ones are down, BGP will automatically search for the LDP LSP with a FEC prefix corresponding to the same /32 prefix in the tunnel table and will resolve the BGP next-hop to it.</p> <p>The <b>disallow-igp</b> option also deprecates the existing one under BGP. It continues to work transparently regardless of which type of LSP shortcut, RSVP or LDP, is being used by BGP at any given time. When this option is enabled and if an LSP shortcut of the configured type is not available, the IGP next-hop route will not be used for the BGP next-hop resolution.</p> |
| <b>Default</b>     | no igp-shortcut                                                                                                                                                                                                                                                                                                                                                                                                                                                                                                                                                                                                                                                                                                                                                                                                                                                                                                                                                                                                                                                                                                                                                                                                                                                                                                                                                                                                                                                                                  |
| <b>Parameters</b>  | <p><b>ldp</b> — Enables the use of LDP LSPs for BGP next-hop resolution by BGP.</p> <p><b>rsvp-te</b> — Enables the use of RSVP LSPs for BGP next-hop resolution by BGP.</p> <p><b>mpls</b> — Enables the use of both RSVP and LDP LSPs for BGP next-hop resolution by BGP. RSVP LSPs are preferred.</p> <p><b>disallow-igp</b> — Prevents BGP next-hop resolution to a regular IGP next-hop if no LSP shortcut was found.</p>                                                                                                                                                                                                                                                                                                                                                                                                                                                                                                                                                                                                                                                                                                                                                                                                                                                                                                                                                                                                                                                                   |

## Configuration Commands

### import

|                    |                                                                                                                                                                                                                                                                                                                                                                                                                                                                                                                                                                                                                                                                                                                                                                                                                                                                                                                                                                                                                                                          |
|--------------------|----------------------------------------------------------------------------------------------------------------------------------------------------------------------------------------------------------------------------------------------------------------------------------------------------------------------------------------------------------------------------------------------------------------------------------------------------------------------------------------------------------------------------------------------------------------------------------------------------------------------------------------------------------------------------------------------------------------------------------------------------------------------------------------------------------------------------------------------------------------------------------------------------------------------------------------------------------------------------------------------------------------------------------------------------------|
| <b>Syntax</b>      | <b>import</b> <i>policy-name</i> [ <i>policy-name...</i> ]<br><b>no import</b> [ <i>policy-name</i> ]                                                                                                                                                                                                                                                                                                                                                                                                                                                                                                                                                                                                                                                                                                                                                                                                                                                                                                                                                    |
| <b>Context</b>     | config>router>bgp<br>config>router>bgp>group<br>config>router>bgp>group>neighbor                                                                                                                                                                                                                                                                                                                                                                                                                                                                                                                                                                                                                                                                                                                                                                                                                                                                                                                                                                         |
| <b>Description</b> | <p>This command specifies the import route policy to be used to determine which routes are accepted from peers. Route policies are configured in the <b>config&gt;router&gt;policy-options</b> context.</p> <p>This configuration parameter can be set at three levels: global level (applies to all peers), group level (applies to all peers in peer-group) or neighbor level (only applies to specified peer). The most specific level is used.</p> <p>When multiple policy names are specified, the policies are evaluated in the order they are specified. A maximum of five (5) policy names can be specified. The first policy that matches is applied.</p> <p>When multiple <b>import</b> commands are issued, the last command entered will override the previous command.</p> <p>When an import policy is not specified, BGP routes are accepted by default.</p> <p>The <b>no</b> form of the command removes the policy association with the BGP instance. To remove association of all policies, use <b>no import</b> without arguments.</p> |
| <b>Default</b>     | <b>no import</b> — No import policy specified (BGP routes are accepted).                                                                                                                                                                                                                                                                                                                                                                                                                                                                                                                                                                                                                                                                                                                                                                                                                                                                                                                                                                                 |
| <b>Parameters</b>  | <i>policy-name</i> — The route policy name. Allowed values are any string up to 32 characters long composed of printable, 7-bit ASCII characters. If the string contains special characters (#, \$, spaces, etc.), the entire string must be enclosed within double quotes. Route policies are configured in the <b>config&gt;router&gt;policy-options</b> context.                                                                                                                                                                                                                                                                                                                                                                                                                                                                                                                                                                                                                                                                                      |

### keepalive

|                    |                                                                                                                                                                                                                                                                                                                                                                                                                                                                                                                                                                                                                                                                                                                                                                                                                                                                                                                                                                                   |
|--------------------|-----------------------------------------------------------------------------------------------------------------------------------------------------------------------------------------------------------------------------------------------------------------------------------------------------------------------------------------------------------------------------------------------------------------------------------------------------------------------------------------------------------------------------------------------------------------------------------------------------------------------------------------------------------------------------------------------------------------------------------------------------------------------------------------------------------------------------------------------------------------------------------------------------------------------------------------------------------------------------------|
| <b>Syntax</b>      | <b>keepalive</b> <i>seconds</i><br><b>no keepalive</b>                                                                                                                                                                                                                                                                                                                                                                                                                                                                                                                                                                                                                                                                                                                                                                                                                                                                                                                            |
| <b>Context</b>     | config>router>bgp<br>config>router>bgp>group<br>config>router>bgp>group>neighbor                                                                                                                                                                                                                                                                                                                                                                                                                                                                                                                                                                                                                                                                                                                                                                                                                                                                                                  |
| <b>Description</b> | <p>This command configures the BGP keepalive timer. A keepalive message is sent every time this timer expires.</p> <p>The <b>keepalive</b> parameter can be set at three levels: global level (applies to all peers), group level (applies to all peers in peer-group) or neighbor level (only applies to specified peer). The most specific value is used.</p> <p>The <b>keepalive</b> value is generally one-third of the <b>hold-time</b> interval. Even though the implementation allows the <b>keepalive</b> value and the <b>hold-time</b> interval to be independently set, under the following circumstances, the configured <b>keepalive</b> value is overridden by the <b>hold-time</b> value:</p> <ol style="list-style-type: none"><li>1. If the specified <b>keepalive</b> value is greater than the configured <b>hold-time</b>, then the specified value is ignored, and the <b>keepalive</b> is set to one third of the current <b>hold-time</b> value.</li></ol> |

2. If the specified **hold-time** interval is less than the configured **keepalive** value, then the **keepalive** value is reset to one third of the specified **hold-time** interval.
3. If the **hold-time** interval is set to zero, then the configured value of the **keepalive** value is ignored. This means that the connection with the peer is up permanently and no **keepalive** packets are sent to the peer.

The **no** form of the command used at the global level reverts to the default value

The **no** form of the command used at the group level reverts to the value defined at the global level.

The **no** form of the command used at the neighbor level reverts to the value defined at the group level.

**Default** 30 seconds

**Parameters** *seconds* — The keepalive timer in seconds expressed as a decimal integer.

**Values** 0 — 21845

## local-address

**Syntax** **local-address** *ip-address*  
**no local-address**

**Context** config>router>bgp>group  
config>router>bgp>group>neighbor

**Description** Configures the local IP address used by the group or neighbor when communicating with BGP peers.

Outgoing connections use the **local-address** as the source of the TCP connection when initiating connections with a peer.

When a local address is not specified, 7750 SR OS uses the system IP address when communicating with IBGP peers and uses the interface address for directly connected EBGP peers. This command is used at the neighbor level to revert to the value defined under the group level.

The **no** form of the command removes the configured local-address for BGP.

The **no** form of the command used at the group level reverts to the value defined at the global level.

The **no** form of the command used at the neighbor level reverts to the value defined at the group level.

**Default** **no local-address** - The router ID is used when communicating with IBGP peers and the interface address is used for directly connected EBGP peers.

*ip-address* — The local address expressed in dotted decimal notation. Allowed value is a valid routable IP address on the router, either an interface or system IP address.

**Values**

|               |                                     |
|---------------|-------------------------------------|
| ipv4-address: | a.b.c.d (host bits must be 0)       |
| ipv6-address: | x:x:x:x:x:x:x (eight 16-bit pieces) |
|               | x:x:x:x:x:d.d.d.d                   |
|               | x: [0 — FFFF]H                      |
|               | d: [0 — 255]D                       |

## Configuration Commands

### local-as

**Syntax** **local-as** *as-number* [**private**]  
**no local-as**

**Context** config>router>bgp  
config>router>bgp>group  
config>router>bgp>group>neighbor

**Description** This command configures a BGP virtual autonomous system (AS) number.

In addition to the global AS number configured for BGP in the config>router>autonomous-system context, a virtual (local) AS number can be configured to support various AS number migration scenarios. The local AS number is added to the beginning of the as-path attribute ahead of the router's AS number.

This configuration parameter can be set at three levels: global level (applies to all EBGP peers), group level (applies to all EBGP peers in peer-group) or neighbor level (only applies to EBGP specified peer). Thus, by specifying this at each neighbor level, it is possible to have a separate local-as per EBGP session. The local-as command is not supported for IBGP sessions. When the optional **private** keyword is specified in the command the local-as number is not added to inbound routes from the EBGP peer that has **local-as** in effect.

When a command is entered multiple times for the same AS, the last command entered is used in the configuration. The **private** attribute can be added or removed dynamically by reissuing the command.

Changing the local AS at the global level in an active BGP instance causes the BGP instance to restart with the new local AS number. Changing the local AS at the global level in an active BGP instance causes BGP to re-establish the peer relationships with all peers in the group with the new local AS number. Changing the local AS at the neighbor level in an active BGP instance causes BGP to re-establish the peer relationship with the new local AS number.

This is an optional command and can be used in the following circumstance:

Provider router P is moved from AS1 to AS2. The customer router that is connected to P, however, is configured to belong to AS1. To avoid reconfiguring the customer router, the **local-as** value on router P can be set to AS1. Thus, router P adds AS1 to the as-path message for routes it advertises to the customer router.

The **no** form of the command used at the global level will remove any virtual AS number configured.

The **no** form of the command used at the group level reverts to the value defined at the global level.

The **no** form of the command used at the neighbor level reverts to the value defined at the group level.

**Default** **no local-as**

**Parameters** *as-number* — The virtual autonomous system number expressed as a decimal integer.

**Values** 1 — 65535

**private** — Specifies the local-as is hidden in paths learned from the peering.

## local-preference

|                    |                                                                                                                                                                                                                                                                                                                                                                                                                                                                                                                                                                                                                                                                                                                                                                                                                                                                                                                                                                                                                                                                                                               |
|--------------------|---------------------------------------------------------------------------------------------------------------------------------------------------------------------------------------------------------------------------------------------------------------------------------------------------------------------------------------------------------------------------------------------------------------------------------------------------------------------------------------------------------------------------------------------------------------------------------------------------------------------------------------------------------------------------------------------------------------------------------------------------------------------------------------------------------------------------------------------------------------------------------------------------------------------------------------------------------------------------------------------------------------------------------------------------------------------------------------------------------------|
| <b>Syntax</b>      | <b>local-preference</b> <i>local-preference</i><br><b>no local-preference</b>                                                                                                                                                                                                                                                                                                                                                                                                                                                                                                                                                                                                                                                                                                                                                                                                                                                                                                                                                                                                                                 |
| <b>Context</b>     | config>router>bgp<br>config>router>bgp>group<br>config>router>bgp>group>neighbor                                                                                                                                                                                                                                                                                                                                                                                                                                                                                                                                                                                                                                                                                                                                                                                                                                                                                                                                                                                                                              |
| <b>Description</b> | <p>This command enables setting the BGP local-preference attribute in incoming routes if not specified and configures the default value for the attribute.</p> <p>This value is used if the BGP route arrives from a BGP peer without the <b>local-preference</b> integer set.</p> <p>The specified value can be overridden by any value set via a route policy. This configuration parameter can be set at three levels: global level (applies to all peers), group level (applies to all peers in peer-group) or neighbor level (only applies to specified peer). The most specific value is used.</p> <p>The <b>no</b> form of the command at the global level specifies that incoming routes with local-preference set are not overridden and routes arriving without local-preference set are interpreted as if the route had local-preference value of 100.</p> <p>The <b>no</b> form of the command used at the group level reverts to the value defined at the global level.</p> <p>The <b>no</b> form of the command used at the neighbor level reverts to the value defined at the group level.</p> |
| <b>Default</b>     | <b>no local-preference</b> — Does not override the local-preference value set in arriving routes and analyze routes without local preference with value of 100.                                                                                                                                                                                                                                                                                                                                                                                                                                                                                                                                                                                                                                                                                                                                                                                                                                                                                                                                               |
| <b>Parameters</b>  | <p><i>local-preference</i> — The local preference value to be used as the override value expressed as a decimal integer.</p> <p><b>Values</b>      0 — 4294967295</p>                                                                                                                                                                                                                                                                                                                                                                                                                                                                                                                                                                                                                                                                                                                                                                                                                                                                                                                                         |

## loop-detect

|                    |                                                                                                                                                                                                                                                                                                                                                                                                                                                                                                                                                                                                                                                                                      |
|--------------------|--------------------------------------------------------------------------------------------------------------------------------------------------------------------------------------------------------------------------------------------------------------------------------------------------------------------------------------------------------------------------------------------------------------------------------------------------------------------------------------------------------------------------------------------------------------------------------------------------------------------------------------------------------------------------------------|
| <b>Syntax</b>      | <b>loop-detect</b> { <b>drop-peer</b>   <b>discard-route</b>   <b>ignore-loop</b>   <b>off</b> }<br><b>no loop-detect</b>                                                                                                                                                                                                                                                                                                                                                                                                                                                                                                                                                            |
| <b>Context</b>     | config>router>bgp<br>config>router>bgp>group<br>config>router>bgp>group>neighbor                                                                                                                                                                                                                                                                                                                                                                                                                                                                                                                                                                                                     |
| <b>Description</b> | <p>This command configures how the BGP peer session handles loop detection in the AS path.</p> <p>This configuration parameter can be set at three levels: global level (applies to all peers), group level (applies to all peers in peer-group) or neighbor level (only applies to specified peer). The most specific value is used.</p> <p>Note that dynamic configuration changes of <b>loop-detect</b> are not recognized.</p> <p>The <b>no</b> form of the command used at the global level reverts to default, which is <b>loop-detect ignore-loop</b>.</p> <p>The <b>no</b> form of the command used at the group level reverts to the value defined at the global level.</p> |

## Configuration Commands

The **no** form of the command used at the neighbor level reverts to the value defined at the group level.

**Default** **loop-detect ignore-loop**

**Parameters** **drop-peer** — Sends a notification to the remote peer and drops the session.

**discard-route** — Discards routes received from a peer with the same AS number as the router itself. This option prevents routes looped back to the router from being added to the routing information base and consuming memory. When this option is changed, the change will not be active for an established peer until the connection is re-established for the peer.

**ignore-loop** — Ignores routes with loops in the AS path but maintains peering.

**off** — Disables loop detection.

## mdt-safi

**Syntax** **[no] mdt-safi**

**Context**  
config>router>bgp  
config>router>bgp>group  
config>router>bgp>group>neighbor

**Description** This command enables peer capability to exchange MDT-SAFI address family advertisements.

## med-out

**Syntax** **med-out {number | igp-cost}**  
**no med-out**

**Context**  
config>router>bgp  
config>router>bgp>group  
config>router>bgp>group>neighbor

**Description** This command enables advertising the Multi-Exit Discriminator (MED) and assigns the value used for the path attribute for the MED advertised to BGP peers if the MED is not already set.

The specified value can be overridden by any value set via a route policy.

This configuration parameter can be set at three levels: global level (applies to all peers), group level (applies to all peers in peer-group) or neighbor level (only applies to specified peer). The most specific value is used.

The **no** form of the command used at the global level reverts to default where the MED is not advertised.

The **no** form of the command used at the group level reverts to the value defined at the global level.

The **no** form of the command used at the neighbor level reverts to the value defined at the group level.

**Default** **no med-out**

**Parameters** *number* — The MED path attribute value expressed as a decimal integer.

**Values** 0 — 4294967295



**igp-cost** — The MED is set to the IGP cost of the given IP prefix.

## min-as-origination

|                    |                                                                                                                                                                                                                                                                                                                                                                                                                                                                                                                                                                                                                                                                                                                                   |
|--------------------|-----------------------------------------------------------------------------------------------------------------------------------------------------------------------------------------------------------------------------------------------------------------------------------------------------------------------------------------------------------------------------------------------------------------------------------------------------------------------------------------------------------------------------------------------------------------------------------------------------------------------------------------------------------------------------------------------------------------------------------|
| <b>Syntax</b>      | <b>min-as-origination</b> <i>seconds</i><br><b>no min-as-origination</b>                                                                                                                                                                                                                                                                                                                                                                                                                                                                                                                                                                                                                                                          |
| <b>Context</b>     | config>router>bgp<br>config>router>bgp>group<br>config>router>bgp>group>neighbor                                                                                                                                                                                                                                                                                                                                                                                                                                                                                                                                                                                                                                                  |
| <b>Description</b> | <p>This command configures the minimum interval, in seconds, at which a path attribute, originated by the local router, can be advertised to a peer.</p> <p>This configuration parameter can be set at three levels: global level (applies to all peers), group level (applies to all peers in peer-group) or neighbor level (only applies to specified peer). The most specific value is used.</p> <p>The <b>no</b> form of the command used at the global level reverts to default.</p> <p>The <b>no</b> form of the command used at the group level reverts to the value defined at the global level.</p> <p>The <b>no</b> form of the command used at the neighbor level reverts to the value defined at the group level.</p> |
| <b>Default</b>     | 15 seconds                                                                                                                                                                                                                                                                                                                                                                                                                                                                                                                                                                                                                                                                                                                        |
| <b>Parameters</b>  | <p><i>seconds</i> — The minimum path attribute advertising interval in seconds expressed as a decimal integer.</p> <p><b>Values</b> 2 — 255</p>                                                                                                                                                                                                                                                                                                                                                                                                                                                                                                                                                                                   |

## min-route-advertisement

|                    |                                                                                                                                                                                                                                                                                                                                                                                                                                                                                                                                                                                                                                                                                          |
|--------------------|------------------------------------------------------------------------------------------------------------------------------------------------------------------------------------------------------------------------------------------------------------------------------------------------------------------------------------------------------------------------------------------------------------------------------------------------------------------------------------------------------------------------------------------------------------------------------------------------------------------------------------------------------------------------------------------|
| <b>Syntax</b>      | <b>min-route-advertisement</b> <i>seconds</i><br><b>no min-route-advertisement</b>                                                                                                                                                                                                                                                                                                                                                                                                                                                                                                                                                                                                       |
| <b>Context</b>     | config>router>bgp<br>config>router>bgp>group<br>config>router>bgp>group>neighbor                                                                                                                                                                                                                                                                                                                                                                                                                                                                                                                                                                                                         |
| <b>Description</b> | <p>This command configures the minimum interval, in seconds, at which a prefix can be advertised to a peer.</p> <p>This configuration parameter can be set at three levels: global level (applies to all peers), group level (applies to all peers in peer-group) or neighbor level (only applies to specified peer). The most specific value is used.</p> <p>The <b>no</b> form of the command used at the global level reverts to default.</p> <p>The <b>no</b> form of the command used at the group level reverts to the value defined at the global level.</p> <p>The <b>no</b> form of the command used at the neighbor level reverts to the value defined at the group level.</p> |
| <b>Default</b>     | 30 seconds                                                                                                                                                                                                                                                                                                                                                                                                                                                                                                                                                                                                                                                                               |

## Configuration Commands

**Parameters** *seconds* — The minimum route advertising interval, in seconds, expressed as a decimal integer.

**Values** 1—255

### mp-bgp-keep

**Syntax** **[no] mp-bgp-keep**

**Context** config>router>bgp

**Description** As a result of enabling this command, route refresh messages are no longer needed, or issued when VPN route policy changes are made; RIB-IN will retain all MP-BGP routes.

The **no** form of the command is used to disable this feature.

### multihop

**Syntax** **multihop *ttl-value***  
**no multihop**

**Context** config>router>bgp  
config>router>bgp>group  
config>router>bgp>group>neighbor

**Description** This command configures the time to live (TTL) value entered in the IP header of packets sent to an EBGp peer multiple hops away.

The **no** form of the command is used to convey to the BGP instance that the EBGp peers are directly connected.

The **no** form of the command used at the global level reverts to default.

The **no** form of the command used at the group level reverts to the value defined at the global level.

The **no** form of the command used at the neighbor level reverts to the value defined at the group level.

**Default** 1 — EBGp peers are directly connected.

64 — IBGP

**Parameters** *ttl-value* — The TTL value expressed as a decimal integer.

**Values** 1 — 255

### multipath

**Syntax** **multipath *integer***  
**no multipath**

**Context** config>router>bgp

**Description** This command enables BGP multipath.

When multipath is enabled BGP load shares traffic across multiple links. Multipath can be configured to load share traffic across a maximum of 32 routes. If the equal cost routes available are more than the configured value, then routes with the lowest next-hop IP address value are chosen.

This configuration parameter is set at the global level (applies to all peers).

Multipath is effectively disabled if the value is set to one. When multipath is disabled, and multiple equal cost routes are available, the route with the lowest next-hop IP address will be used.

The **no** form of the command used at the global level reverts to default where **multipath** is disabled.

**Default** **no multipath**

**Parameters** *integer* — The number of equal cost routes to use for multipath routing. If more equal cost routes exist than the configured value, routes with the lowest next-hop value are chosen. Setting this value to 1 disables multipath.

**Values** 1 — 32

## outbound-route-filtering

**Syntax** **[no] outbound-route-filtering**

**Context** config>router>bgp  
config>router>bgp>group  
config>router>bgp>group>neighbor

**Description** This command opens the configuration tree for sending or accepting BGP filter lists from peers (outbound route filtering).

**Default** no outbound-route-filtering

## extended-community

**Syntax** **[no] extended-community**

**Context** config>router>bgp  
config>router>bgp>group  
config>router>bgp>group>neighbor

**Description** The extended-community command opens the configuration tree for sending or accepting extended-community based BGP filters.

In order for the **no** version of the command to work, all sub-commands (**send-orf**, **accept-orf**) must be removed first.

**Default** Community filtering is not enabled by default.

## Configuration Commands

### accept-orf

**Syntax** [no] accept-orf

**Context** config>router>bgp  
config>router>bgp>group  
config>router>bgp>group>neighbor

**Description** This command instructs the router to negotiate the receive capability in the BGP ORF negotiation with a peer, and to accept filters that the peer wishes to send.  
The **no** form of the command causes the router to remove the accept capability in the BGP ORF negotiation with a peer, and to clear any existing ORF filters that are currently in place.

**Default** Accepting ORFs is not enabled by default.

### send-orf

**Syntax** **send-orf** [*comm-id*...(up to 32 max)]  
**no send-orf** [*comm-id*]

**Context** config>router>bgp  
config>router>bgp>group  
config>router>bgp>group>neighbor

**Description** This command instructs the router to negotiate the send capability in the BGP outbound route filtering (ORF) negotiation with a peer.  
This command also causes the router to send a community filter, prefix filter, or AS path filter configured as an inbound filter on the BGP session to its peer as an ORF Action ADD.  
The **no** form of this command causes the router to remove the send capability in the BGP ORF negotiation with a peer.  
The **no** form also causes the router to send an ORF remove action for a community filter, prefix filter, or AS path filter configured as an inbound filter on the BGP session to its peer.  
If the *comm-id* parameter(s) are not exclusively route target communities then the router will extract appropriate route targets and use those. If, for some reason, the *comm-id* parameter(s) specified contain no route targets, then the router will not send an ORF.

**Default** no send-orf — Sending ORF is not enabled by default.

**Parameters** *comm-id* — Any community policy which consists exclusively of route target extended communities. If it is not specified, then the ORF policy is automatically generated from configured route target lists, accepted client route target ORFs and locally configured route targets.

## neighbor

|                    |                                                                                                                                                                                                                                                                                                                                                                                                                                                                                                                                                                                                                       |               |                                                                                                                                                                                                                                    |
|--------------------|-----------------------------------------------------------------------------------------------------------------------------------------------------------------------------------------------------------------------------------------------------------------------------------------------------------------------------------------------------------------------------------------------------------------------------------------------------------------------------------------------------------------------------------------------------------------------------------------------------------------------|---------------|------------------------------------------------------------------------------------------------------------------------------------------------------------------------------------------------------------------------------------|
| <b>Syntax</b>      | <b>[no] neighbor</b> <i>ip-address</i>                                                                                                                                                                                                                                                                                                                                                                                                                                                                                                                                                                                |               |                                                                                                                                                                                                                                    |
| <b>Context</b>     | config>router>bgp>group                                                                                                                                                                                                                                                                                                                                                                                                                                                                                                                                                                                               |               |                                                                                                                                                                                                                                    |
| <b>Description</b> | <p>This command creates a BGP peer/neighbor instance within the context of the BGP group.</p> <p>This command can be issued repeatedly to create multiple peers and their associated configuration.</p> <p>The <b>no</b> form of the command is used to remove the specified neighbor and the entire configuration associated with the neighbor. The neighbor must be administratively <b>shutdown</b> before attempting to delete it. If the neighbor is not shutdown, the command will not result in any action except a warning message on the console indicating that neighbor is still administratively up.</p>  |               |                                                                                                                                                                                                                                    |
| <b>Default</b>     | No neighbors are defined.                                                                                                                                                                                                                                                                                                                                                                                                                                                                                                                                                                                             |               |                                                                                                                                                                                                                                    |
| <b>Parameters</b>  | <p><i>ip-address</i> — The IP address of the BGP peer router in dotted decimal notation.</p> <table border="0" style="margin-left: 2em;"> <tr> <td style="vertical-align: top;"><b>Values</b></td> <td>           ipv4-address: a.b.c.d (host bits must be 0)<br/>           ipv6-address: x:x:x:x:x:x:x[-interface]<br/>                             x:x:x:x:x:d.d.d.d[-interface]<br/>                             x: [0 — FFFF]H<br/>                             d: [0 — 255]D<br/>                             interface: 32 characters maximum, mandatory for link local addresses         </td> </tr> </table> | <b>Values</b> | ipv4-address: a.b.c.d (host bits must be 0)<br>ipv6-address: x:x:x:x:x:x:x[-interface]<br>x:x:x:x:x:d.d.d.d[-interface]<br>x: [0 — FFFF]H<br>d: [0 — 255]D<br>interface: 32 characters maximum, mandatory for link local addresses |
| <b>Values</b>      | ipv4-address: a.b.c.d (host bits must be 0)<br>ipv6-address: x:x:x:x:x:x:x[-interface]<br>x:x:x:x:x:d.d.d.d[-interface]<br>x: [0 — FFFF]H<br>d: [0 — 255]D<br>interface: 32 characters maximum, mandatory for link local addresses                                                                                                                                                                                                                                                                                                                                                                                    |               |                                                                                                                                                                                                                                    |

## next-hop-self

|                    |                                                                                                                                                                                                                                                                                                                                                                                                                                                                                                                                                                                                                                                                                                                  |
|--------------------|------------------------------------------------------------------------------------------------------------------------------------------------------------------------------------------------------------------------------------------------------------------------------------------------------------------------------------------------------------------------------------------------------------------------------------------------------------------------------------------------------------------------------------------------------------------------------------------------------------------------------------------------------------------------------------------------------------------|
| <b>Syntax</b>      | <b>[no] next-hop-self</b> {[ <b>ipv4</b> ] [ <b>vpn-ipv4</b> ] [ <b>ipv6</b> ] [ <b>mcast-ipv4</b> ] [ <b>l2-vpn</b> ]} [ <b>multihoming</b> <i>primary-anycast secondary-anycast</i> ]                                                                                                                                                                                                                                                                                                                                                                                                                                                                                                                          |
| <b>Context</b>     | config>router>bgp>group<br>config>router>bgp>group>neighbor                                                                                                                                                                                                                                                                                                                                                                                                                                                                                                                                                                                                                                                      |
| <b>Description</b> | <p>This command configures the group or neighbor to always set the NEXTHOP path attribute to its own physical interface when advertising to a peer.</p> <p>This is primarily used to avoid third-party route advertisements when connected to a multi-access network.</p> <p>In addition, this command can be used to enable and configure the multi-homing resiliency mechanism replacing the usual BGP nexthop with a configured anycast address.</p> <p>The <b>no</b> form of the command used at the group level allows third-party route advertisements in a multi-access network.</p> <p>The <b>no</b> form of the command used at the neighbor level reverts to the value defined at the group level.</p> |
| <b>Default</b>     | <b>no next-hop-self</b> — Third-party route advertisements are allowed.                                                                                                                                                                                                                                                                                                                                                                                                                                                                                                                                                                                                                                          |
| <b>Parameters</b>  | <p><b>ipv4</b> — Provisions support for IPv4 routing information.</p> <p><b>vpn-ipv4</b> — Exchanges IPv4 VPN routing information.</p> <p><b>ipv6</b> — Exchanges IPv6 routing information.</p>                                                                                                                                                                                                                                                                                                                                                                                                                                                                                                                  |

## Configuration Commands

**mcast-ipv4** — Exchanges multicast IPv4 routing information.

**l2-vpn** — Exchanges Layer 2 VPN information.

*primary-anycast* — Specifies the anycast address that the local node will use to replace the BGP nexthop address in route updates associated peers.

*secondary-address* — Specifies the anycast address that the local node is to track.

### passive

**Syntax** **[no] passive**

**Context** config>router>bgp>group  
config>router>bgp>group>neighbor

**Description** Enables/disables passive mode for the BGP group or neighbor.  
When in passive mode, BGP will not attempt to actively connect to the configured BGP peers but responds only when it receives a connect open request from the peer.  
The **no** form of the command used at the group level disables passive mode where BGP actively attempts to connect to its peers.  
The **no** form of the command used at the neighbor level reverts to the value defined at the group level.

**Default** **no passive** — BGP will actively try to connect to all the configured peers.

### peer-as

**Syntax** **peer-as as-number**

**Context** config>router>bgp>group  
config>router>bgp>group>neighbor

**Description** This command configures the autonomous system number for the remote peer. The peer AS number must be configured for each configured peer.  
For EBGp peers, the peer AS number configured must be different from the autonomous system number configured for this router under the global level since the peer will be in a different autonomous system than this router  
For IBGP peers, the peer AS number must be the same as the autonomous system number of this router configured under the global level.  
This is required command for each configured peer. This may be configured under the group level for all neighbors in a particular group.

**Default** No AS numbers are defined.

**Parameters** *as-number* — The autonomous system number expressed as a decimal integer.

**Values** 1 — 4294967295

## path-mtu-discovery

**Syntax** [no] path-mtu-discovery

**Context** config>router>bgp  
config>router>bgp>group  
config>router>bgp>group>neighbor

**Description** This command enables path MTU discovery for the associated TCP connections. In doing so, the MTU for the associated TCP session will be initially set to the egress interface MTU. The DF bit will also be set so that if a router along the path of the TCP connection cannot handle a packet of a particular size without fragmenting, it will send back an ICMP message to set the path MTU for the given session to a lower value that can be forwarded without fragmenting.

The **no** form of the command disables path MTU discovery.

**Default** no path-mtu-discovery

## preference

**Syntax** [no] preference *preference*

**Context** config>router>bgp  
config>router>bgp>group  
config>router>bgp>group>neighbor

**Description** This command configures the route preference for routes learned from the configured peer(s). This configuration parameter can be set at three levels: global level (applies to all peers), group level (applies to all peers in peer-group) or neighbor level (only applies to specified peer). The most specific value is used.

The lower the preference the higher the chance of the route being the active route. 7750 SR OS assigns BGP routes highest default preference compared to routes that are direct, static or learned via MPLS or OSPF.

The **no** form of the command used at the global level reverts to default value.

The **no** form of the command used at the group level reverts to the value defined at the global level.

The **no** form of the command used at the neighbor level reverts to the value defined at the group level.

**Default** 170

**Parameters** *preference* — The route preference expressed as a decimal integer.

**Values** 1 — 255

## Configuration Commands

### rapid-update

|                    |                                                                                                                                                                                                     |
|--------------------|-----------------------------------------------------------------------------------------------------------------------------------------------------------------------------------------------------|
| <b>Syntax</b>      | <b>rapid-update</b> {[I2-vpn] [mvpn-ipv4] [mdt-safi]}<br><b>no rapid-update</b> { [I2-vpn] [mvpn-ipv4] [mdt-safi]}                                                                                  |
| <b>Context</b>     | config>router>bgp                                                                                                                                                                                   |
| <b>Description</b> | This command enables and disables BGP rapid update for specified address-families. When no parameter is given for the no rapid-update statement, rapid update is disabled for all address-families. |
| <b>Default</b>     | no rapid-update                                                                                                                                                                                     |

### rapid-withdrawal

|                    |                                                                                                                                                                                                                                                                                                                                                                       |
|--------------------|-----------------------------------------------------------------------------------------------------------------------------------------------------------------------------------------------------------------------------------------------------------------------------------------------------------------------------------------------------------------------|
| <b>Syntax</b>      | [no] <b>rapid-withdrawal</b>                                                                                                                                                                                                                                                                                                                                          |
| <b>Context</b>     | config>router>bgp                                                                                                                                                                                                                                                                                                                                                     |
| <b>Description</b> | This command disables the delay (Minimum Route Advertisement) on sending BGP withdrawals. Normal route withdrawals may be delayed up to the minimum route advertisement to allow for efficient packing of BGP updates.<br><br>The <b>no</b> form of the command removes this command from the configuration and returns withdrawal processing to the normal behavior. |
| <b>Default</b>     | no rapid-withdrawal                                                                                                                                                                                                                                                                                                                                                   |

### prefix-limit

|                    |                                                                                                                                                                                                                                                                                                                   |
|--------------------|-------------------------------------------------------------------------------------------------------------------------------------------------------------------------------------------------------------------------------------------------------------------------------------------------------------------|
| <b>Syntax</b>      | <b>prefix-limit</b> <i>limit</i> [ <b>log-only</b> ] [ <b>threshold</b> <i>percent</i> ]<br><b>no prefix-limit</b>                                                                                                                                                                                                |
| <b>Context</b>     | config>router>bgp>group<br>config>router>bgp>group>neighbor                                                                                                                                                                                                                                                       |
| <b>Description</b> | This command configures the maximum number of routes BGP can learn from a peer.<br><br>When the number of routes reaches 90% of this limit, an SNMP trap is sent. When the limit is exceeded, the BGP peering is dropped and disabled.<br><br>The <b>no</b> form of the command removes the <b>prefix-limit</b> . |
| <b>Parameters</b>  | <b>log-only</b> — Enables the warning message to be sent at the specified threshold percentage, and also when the limit is exceeded. However, the BGP peering is not dropped.<br><br><i>percent</i> — The threshold value (as a percentage) that triggers a warning message to be sent.                           |
| <b>Default</b>     | <b>no prefix-limit</b>                                                                                                                                                                                                                                                                                            |
| <b>Parameters</b>  | <i>limit</i> — The number of routes that can be learned from a peer expressed as a decimal integer.<br><br><b>Values</b> 1 — 4294967295                                                                                                                                                                           |



## remove-private

**Syntax** [no] remove-private {limited}

**Context** config>router>bgp  
config>router>bgp>group  
config>router>bgp>group>neighbor

**Description** This command allows private AS numbers to be removed from the AS path before advertising them to BGP peers.

When the **remove-private** parameter is set at the global level, it applies to all peers regardless of group or neighbor configuration. When the parameter is set at the group level, it applies to all peers in the group regardless of the neighbor configuration.

7750 SR OS software recognizes the set of AS numbers that are defined by IANA as private. These are AS numbers in the range 64512 through 65535, inclusive.

The **no** form of the command used at the global level reverts to default value. The **no** form of the command used at the group level reverts to the value defined at the global level. The **no** form of the command used at the neighbor level reverts to the value defined at the group level.

**Default** **no remove-private** — Private AS numbers will be included in the AS path attribute.

**limited** — This optional keyword removes private ASNs up to the first public ASN encountered. It then stops removing private ASNs.

## router-id

**Syntax** **router-id** *ip-address*  
**no router-id**

**Context** config>router>bgp

**Description** This command specifies the router ID to be used with this BGP instance.

Changing the BGP router ID on an active BGP instance causes the BGP instance to restart with the new router ID. The router ID must be set to a valid host address.

**Default** No router-id is configured for BGP by default. The system interface IP address is used.

**Parameters** *ip-address* — The router ID expressed in dotted decimal notation. Allowed value is a valid routable IP address on the router, either an interface or system IP address. It is highly recommended that this address be the system IP address.

### transport-tunnel

|                    |                                                                                                                                                                                                                                                                                                                                                     |
|--------------------|-----------------------------------------------------------------------------------------------------------------------------------------------------------------------------------------------------------------------------------------------------------------------------------------------------------------------------------------------------|
| <b>Syntax</b>      | <b>transport-tunnel</b> <i>ldp</i>   <i>rsvp-te</i>   <i>mpls</i>                                                                                                                                                                                                                                                                                   |
| <b>Context</b>     | config>router>bgp                                                                                                                                                                                                                                                                                                                                   |
| <b>Description</b> | This command selects the transport LSP option to provide model B or C connectivity.<br>The <b>no</b> form of the command defaults to LDP as transport LSP method for model B or C connectivity.                                                                                                                                                     |
| <b>Default</b>     | transport-tunnel ldp                                                                                                                                                                                                                                                                                                                                |
| <b>Parameters</b>  | <i>ldp</i> — Allows LDP-based LSPs to be used as transport from the ASBR to local PE routers.<br><i>rsvp-te</i> — Allows RSVP-TE based LSPs to be used as transport from the ASBR to local PE routers.<br><i>mpls</i> — Specifies that both LDP and RSVP-TE can be used to resolve the BGP next-hop for VPRN routes in an associated VPRN instance. |

### shutdown

|                      |                                                                                                                                                                                                                                                                                                                                                                                                                                                                                                                                                                                                                                                                                                                                                                                                                                                                  |
|----------------------|------------------------------------------------------------------------------------------------------------------------------------------------------------------------------------------------------------------------------------------------------------------------------------------------------------------------------------------------------------------------------------------------------------------------------------------------------------------------------------------------------------------------------------------------------------------------------------------------------------------------------------------------------------------------------------------------------------------------------------------------------------------------------------------------------------------------------------------------------------------|
| <b>Syntax</b>        | <b>[no] shutdown</b>                                                                                                                                                                                                                                                                                                                                                                                                                                                                                                                                                                                                                                                                                                                                                                                                                                             |
| <b>Context</b>       | config>router>bgp<br>config>router>bgp>group<br>config>router>bgp>group>neighbor                                                                                                                                                                                                                                                                                                                                                                                                                                                                                                                                                                                                                                                                                                                                                                                 |
| <b>Description</b>   | This command administratively disables an entity. When disabled, an entity does not change, reset, or remove any configuration settings or statistics.<br><br>The operational state of the entity is disabled as well as the operational state of any entities contained within. Many objects must be shut down before they may be deleted.<br><br>The <b>no</b> form of this command administratively enables an entity.<br><br>Unlike other commands and parameters where the default state is not indicated in the configuration file, the <b>shutdown</b> and <b>no shutdown</b> states are always indicated in system generated configuration files.<br><br>Default administrative states for services and service entities are described in Special Cases.<br><br>The <b>no</b> form of the command places an entity in an administratively enabled state. |
| <b>Special Cases</b> | <b>BGP Global</b> — The BGP protocol is created in the <b>no shutdown</b> state.<br><b>BGP Group</b> — BGP groups are created in the <b>no shutdown</b> state.<br><b>BGP Neighbor</b> — BGP neighbors/peers are created in the <b>no shutdown</b> state.                                                                                                                                                                                                                                                                                                                                                                                                                                                                                                                                                                                                         |

## ttl-security

|                    |                                                                                                                                                                                                                                                                                                                                        |
|--------------------|----------------------------------------------------------------------------------------------------------------------------------------------------------------------------------------------------------------------------------------------------------------------------------------------------------------------------------------|
| <b>Syntax</b>      | <b>ttl-security</b> <i>min-ttl-value</i><br><b>no ttl-security</b>                                                                                                                                                                                                                                                                     |
| <b>Context</b>     | config>router>bgp>group<br>config>router>bgp>group>neighbor                                                                                                                                                                                                                                                                            |
| <b>Description</b> | This command configures TTL security parameters for incoming packets. When the feature is enabled, BGP/LDP will accept incoming IP packets from a peer only if the TTL value in the packet is greater than or equal to the minimum TTL value configured for that peer.<br><br>The <b>no</b> form of the command disables TTL security. |
| <b>Parameters</b>  | <i>min-ttl-value</i> — Specify the minimum TTL value for an incoming packet.                                                                                                                                                                                                                                                           |
|                    | <b>Values</b> 1 — 255                                                                                                                                                                                                                                                                                                                  |
|                    | <b>Default</b> 1                                                                                                                                                                                                                                                                                                                       |

## type

|                    |                                                                                                                                                                                                                                                                                                                                                                                                                                                                                                                                                                                                                                                                                                              |
|--------------------|--------------------------------------------------------------------------------------------------------------------------------------------------------------------------------------------------------------------------------------------------------------------------------------------------------------------------------------------------------------------------------------------------------------------------------------------------------------------------------------------------------------------------------------------------------------------------------------------------------------------------------------------------------------------------------------------------------------|
| <b>Syntax</b>      | <b>[no] type</b> { <b>internal</b>   <b>external</b> }                                                                                                                                                                                                                                                                                                                                                                                                                                                                                                                                                                                                                                                       |
| <b>Context</b>     | config>router>bgp>group<br>config>router>bgp>group>neighbor                                                                                                                                                                                                                                                                                                                                                                                                                                                                                                                                                                                                                                                  |
| <b>Description</b> | This command designates the BGP peer as type internal or external.<br><br>The type of <b>internal</b> indicates the peer is an IBGP peer while the type of external indicates that the peer is an EBGP peer.<br><br>By default, 7750 SR OS derives the type of neighbor based on the local AS specified. If the local AS specified is the same as the AS of the router, the peer is considered <b>internal</b> . If the local AS is different, then the peer is considered <b>external</b> .<br><br>The <b>no</b> form of the command used at the group level reverts to the default value.<br>The <b>no</b> form of the command used at the neighbor level reverts to the value defined at the group level. |
| <b>Default</b>     | <b>no type</b> — Type of neighbor is derived on the local AS specified.                                                                                                                                                                                                                                                                                                                                                                                                                                                                                                                                                                                                                                      |
| <b>Parameters</b>  | <b>internal</b> — Configures the peer as internal.<br><br><b>external</b> — Configures the peer as external.                                                                                                                                                                                                                                                                                                                                                                                                                                                                                                                                                                                                 |

---

## Other BGP-Related Commands

### autonomous-system

**Syntax** **autonomous-system** *autonomous-system*  
**no autonomous-system**

**Context** config>router

**Description** This command configures the autonomous system (AS) number for the router. A router can only belong to one AS. An AS number is a globally unique number with an AS. This number is used to exchange exterior routing information with neighboring ASs and as an identifier of the AS itself.

If the AS number is changed on a router with an active BGP instance, the new AS number is not used until the BGP instance is restarted either by administratively disabling/enabling (**shutdown/no shutdown**) the BGP instance or rebooting the system with the new configuration.

**Default** No autonomous system number is defined.

**Parameters** *as-number* — The autonomous system number expressed as a decimal integer.

**Values** 1 — 4294967295

### mh-primary-interface

**Syntax** **mh-primary-interface** *interface-name*  
**no mh-primary-interface**

**Context** config>router

**Description** This command creates a loopback interface for the use in multihoming resiliency. Once active this interface can be used to advertise reachability information to the rest of the network using the primary address which is backed up by the secondary

This reachability for this address is advertised via IGP and LDP protocols to allow the resolution of BGP routes advertised with this address.

The no form of the command disables this setting.

**Default** **no mh-primary-interface**

## mh-secondary-interface

**Syntax** **mh-secondary-interface** *interface-name*  
**no mh-secondary-interface**

**Context** config>router

**Description** This command creates a loopback interface for the use in multihoming resiliency. This address is considered the secondary multihoming address and is only used to resolve routes advertised by the primary router in the event that router becomes unavailable. For this purpose, the Reachability for this address is advertised via IGPs and LDP protocols to allow the resolution of BGP routes advertised with this address by the primary multihoming router.

The no form of the command disables this setting.

**Default** **no mh-secondary-interface**

## address

**Syntax** **address** {*ip-address/mask* | *ip-address netmask*}  
**no address**

**Context** config>router>mh-primary-interface  
 config>router>mh-secondary-interface

**Description** This command assigns an IP address, IP subnet, and broadcast address format to an IP interface. Only one IP address can be associated with an IP interface.

An IP address must be assigned to each IP interface for the interface to be active. An IP address and a mask combine to create a local IP prefix. The defined IP prefix must be unique within the context of the routing instance. It cannot overlap with other existing IP prefixes defined as local subnets on other IP interfaces in the same routing context within the router.

The local subnet that the address command defines must not be part of the services address space within the routing context by use of the config router service-prefix command. Once a portion of the address space is allocated as a service prefix, that portion is not available to IP interfaces for network core connectivity.

The IP address for the interface can be entered in either CIDR (Classless Inter-Domain Routing) or traditional dotted decimal notation. Show commands display CIDR notation and are stored in configuration files.

By default, no IP address or subnet association exists on an IP interface until it is explicitly created.

The no form of the command removes the IP address assignment from the IP interface. Interface specific configurations for IGP protocols like OSPF are also removed. The no form of this command can only be performed when the IP interface is administratively shut down. Shutting down the IP interface will operationally stop any protocol interfaces or MPLS LSPs that explicitly reference that IP address. When a new IP address is defined, the IP interface can be administratively enabled (no

shutdown), which reinitializes the protocol interfaces and MPLS LSPs associated with that IP interface.

If a new address is entered while another address is still active, the new address will be rejected.

**Default** **no address**

## Other BGP-Related Commands

|                   |                                                                                                                                                                                                                                                                                                                                                                                                                                                                                                                                                                                                                                                                                                                                                                                                                                                                                                                                                                                                                                                                                                                                                                                                                                                                                                                                                                                                                                                                                                                                                                                                                                                                                                                                                                                                                                                                                                               |
|-------------------|---------------------------------------------------------------------------------------------------------------------------------------------------------------------------------------------------------------------------------------------------------------------------------------------------------------------------------------------------------------------------------------------------------------------------------------------------------------------------------------------------------------------------------------------------------------------------------------------------------------------------------------------------------------------------------------------------------------------------------------------------------------------------------------------------------------------------------------------------------------------------------------------------------------------------------------------------------------------------------------------------------------------------------------------------------------------------------------------------------------------------------------------------------------------------------------------------------------------------------------------------------------------------------------------------------------------------------------------------------------------------------------------------------------------------------------------------------------------------------------------------------------------------------------------------------------------------------------------------------------------------------------------------------------------------------------------------------------------------------------------------------------------------------------------------------------------------------------------------------------------------------------------------------------|
| <b>Parameters</b> | <p><i>ip-address</i> — The IP address of the IP interface. The ip-addr portion of the address command specifies the IP host address that will be used by the IP interface within the subnet. This address must be unique within the subnet and specified in dotted decimal notation.</p> <p><b>Values</b> 1.0.0.0 — 223.255.255.255</p> <p>/ — The forward slash is a parameter delimiter that separates the ip-addr portion of the IP address from the mask that defines the scope of the local subnet. No spaces are allowed between the ipaddr, the “/” and the mask-length parameter. If a forward slash does not ediatly follow the ipaddr, a dotted decimal mask must follow the prefix.</p> <p><i>mask-length</i> — The subnet mask length when the IP prefix is specified in CIDR notation. When the IP prefix is specified in CIDR notation, a forward slash (/) separates the ip-addr from the masklength parameter. The mask length parameter indicates the number of bits used for the network portion of the IP address; the remainder of the IP address is used to determine the host portion of the IP address. Allowed values are integers in the range 1— 32. Note that a mask length of 32 is reserved for system IP addresses.</p> <p><b>Values</b> 1— 3</p> <p><i>mask</i> — The subnet mask in dotted decimal notation. When the IP prefix is not specified in CIDR notation, a space separates the ip-addr from a traditional dotted decimal mask. The mask parameter indicates the complete mask that will be used in a logical ‘AND’ function to derive the local subnet of the IP address. Note that a mask of 255.255.255.255 is reserved for system IP addresses.</p> <p><b>Values</b> 128.0.0.0 — 255.255.255.255</p> <p><i>net-mask</i> — he subnet mask in dotted decimal notation.</p> <p><b>Values</b> 0.0.0.0 — 223.255.255.255 (network bits all 1 and host bits all 0)</p> |
|-------------------|---------------------------------------------------------------------------------------------------------------------------------------------------------------------------------------------------------------------------------------------------------------------------------------------------------------------------------------------------------------------------------------------------------------------------------------------------------------------------------------------------------------------------------------------------------------------------------------------------------------------------------------------------------------------------------------------------------------------------------------------------------------------------------------------------------------------------------------------------------------------------------------------------------------------------------------------------------------------------------------------------------------------------------------------------------------------------------------------------------------------------------------------------------------------------------------------------------------------------------------------------------------------------------------------------------------------------------------------------------------------------------------------------------------------------------------------------------------------------------------------------------------------------------------------------------------------------------------------------------------------------------------------------------------------------------------------------------------------------------------------------------------------------------------------------------------------------------------------------------------------------------------------------------------|

## description

|                    |                                                                                                                                                                                                                                                                                               |
|--------------------|-----------------------------------------------------------------------------------------------------------------------------------------------------------------------------------------------------------------------------------------------------------------------------------------------|
| <b>Syntax</b>      | <b>description</b> <i>description-string</i><br><b>no description</b>                                                                                                                                                                                                                         |
| <b>Context</b>     | config>router>mh-primary-interface<br>config>router>mh-secondary-interface                                                                                                                                                                                                                    |
| <b>Description</b> | This command creates a text description stored in the configuration file for a configuration context. The no form of the command removes the description string from the context.                                                                                                             |
| <b>Default</b>     | <b>no description</b>                                                                                                                                                                                                                                                                         |
| <b>Parameters</b>  | <i>description-string</i> — The description character string. Allowed values are any string up to 80 characters long composed of printable, 7-bit ASCII characters. If the string contains special characters (#, \$, spaces, etc.), the entire string must be enclosed within double quotes. |

## shutdown

**Syntax**    **shutdown**  
**no shutdown**

**Context**    config>router>mh-primary-interface  
 config>router>mh-secondary-interface

**Description**    The shutdown command administratively disables an entity. The operational state of the entity is disabled as well as the operational state of any entities contained within. Many objects must be shut down before they may be deleted.

Unlike other commands and parameters where the default state is not indicated in the configuration file, shutdown and no shutdown are always indicated in system generated configuration files.

The no form of the command puts an entity into the administratively enabled state.

**Default**    **no shutdown**

## hold-time

**Syntax**    **hold-time** *holdover-time*  
**no hold-time**

**Context**    config>router>mh-secondary-interface

**Description**    The optional hold-time parameter is only applicable for the secondary context and specifies how long label information learned about the secondary anycast address should be kept after that peer is declared down. This timer should be set to a value large enough for the remainder of the network to detect the failure and complete the reconvergence process.

The no form of the command resets the hold-time back to the default value.

**Default**    **no hold-time**

**Parameters**    *holdover-time* — (seconds) specifies the number of seconds the router should hold label information learned from the alternate router in its secondary label table. This is to allow the reset of the network to reconverge after a router failure before the anycast based label assignments are flushed from the forwarding plane.

**Values**      0—65535

**Default**      90

## Other BGP-Related Commands

### router-id

**Syntax** **router-id** *ip-address*  
**no router-id**

**Context** config>router

**Description** This command configures the router ID for the router instance.

The router ID is used by both OSPF and BGP routing protocols in this instance of the routing table manager. IS-IS uses the router ID value as its system ID.

When configuring a new router ID, protocols are not automatically restarted with the new router ID. The next time a protocol is initialized, the new router ID is used. This can result in an interim period of time when different protocols use different router IDs.

To force the new router ID to be used, issue the **shutdown** and **no shutdown** commands for each protocol that uses the router ID, or restart the entire router.

The **no** form of the command reverts to the default value.

**Default** The system uses the system interface address (which is also the loopback address).  
If a system interface address is not configured, use the last 32 bits of the chassis MAC address.

**Parameters** *router-id* — The 32 bit router ID expressed in dotted decimal notation or as a decimal value.



---

## Show Commands

### router

|                    |                                                                       |
|--------------------|-----------------------------------------------------------------------|
| <b>Syntax</b>      | <b>router</b> [ <i>router-instance</i> ]                              |
| <b>Context</b>     | show                                                                  |
| <b>Description</b> | Displays router instance information.                                 |
| <b>Parameters</b>  | <i>router-instance</i> — Specify either the router-name or service-id |
| <b>Values</b>      | router-name: Base, management<br>service-id: 1 — 2147483647           |
| <b>Default</b>     | <b>Base</b>                                                           |

### bgp

|                    |                                                         |
|--------------------|---------------------------------------------------------|
| <b>Syntax</b>      | <b>bgp</b>                                              |
| <b>Context</b>     | show>router                                             |
| <b>Description</b> | Enables the context to display BGP related information. |

### auth-keychain

|                    |                                                                               |
|--------------------|-------------------------------------------------------------------------------|
| <b>Syntax</b>      | <b>auth-keychain</b> [ <i>keychain</i> ]                                      |
| <b>Context</b>     | show>router>bgp<br>show>router>bgp>group<br>show>router>bgp>group>neighbor    |
| <b>Description</b> | This command displays BGP sessions using particular authentication key-chain. |
| <b>Parameters</b>  | <i>keychain</i> — Specifies an existing keychain name.                        |

#### Sample Output

```
*A:ALA-48# show router 2 bgp auth-keychain
=====
Sessions using key chains
=====
Peer address Group Keychain name

10.20.1.3 1 eta_keychain1
30.1.0.2 1 eta_keychain1
```

## Show Commands

```
=====
*A:ALA-48#
*A:ALA-48>config>router>bgp# show router bgp group "To_AS_10000"
=====
BGP Group : To_AS_10000

Group : To_AS_10000

Group Type : No Type State : Up
Peer AS : 10000 Local AS : 200
Local Address : n/a Loop Detect : Ignore
Import Policy : None Specified / Inherited
Export Policy : ospf3
Hold Time : 90 Keep Alive : 30
Cluster Id : 0.0.0.100 Client Reflect : Enabled
NLRI : Unicast Preference : 170
TTL Security : Disabled Min TTL Value : n/a
Graceful Restart : Enabled Stale Routes Time: 360
Auth key chain : testname

List of Peers
- 10.0.0.8 :
 To_Router B - EBGp Peer
Total Peers : 1 Established : 0

Peer Groups : 1
=====
*A:ALA-48>config>router>bgp#

*A:ALA-48>config>router>bgp# show router bgp neighbor 10.0.0.8
=====
BGP Neighbor

Peer : 10.0.0.8
Group : To_AS_10000

Peer AS : 10000 Peer Port : 0
Peer Address : 10.0.0.8 Local Port : 0
Local AS : 200 Local Port : 0
Local Address : 0.0.0.0
Peer Type : External
State : Active Last State : Idle
Last Event : stop
Last Error : Cease
Local Family : IPv4
Remote Family : Unused
Hold Time : 90 Keep Alive : 30
Active Hold Time : 0 Active Keep Alive : 0
Cluster Id : 0.0.0.100
Preference : 99 Num of Flaps : 0
Recd. Paths : 0
IPv4 Recd. Prefixes : 0 IPv4 Active Prefixes : 0
VPN-IPv4 Recd. Pfxs : 0 VPN-IPv4 Suppr. Pfxs : 0
VPN-IPv4 Active Pfxs : 0 VPN-IPv4 Active Pfxs : 0
Mc IPv4 Recd. Pfxs. : 0 Mc IPv4 Active Pfxs. : 0
Mc IPv4 Suppr. Pfxs : 0 IPv6 Suppressed Pfxs : 0
IPv6 Recd. Prefixes : 0 IPv6 Active Prefixes : 0
Input Queue : 0 Output Queue : 0
=====
```

```

i/p Messages : 0 o/p Messages : 0
i/p Octets : 0 o/p Octets : 0
i/p Updates : 0 o/p Updates : 0
TTL Security : Disabled Min TTL Value : n/a
Graceful Restart : Enabled Stale Routes Time : 360
Advertise Inactive : Disabled Peer Tracking : Disabled
Advertise Label : None
Auth key chain : testname
Local Capability : RouteRefresh MP-BGP
Remote Capability :
Import Policy : None Specified / Inherited
Export Policy : ospf3

```

```

Neighbors : 1
=====
```

```
*A:ALA-48>config>router>bgp#
```

```
*A:ALA-48>config>router>bgp# show router bgp auth-keychain testname
```

```
=====
Sessions using key chain: keychain
=====
```

| Peer address | Group       | Keychain name |
|--------------|-------------|---------------|
| 10.0.0.8     | To_AS_10000 | testname      |

```
=====
*A:ALA-48>config>router>bgp#
```

## damping

**Syntax** **damping** [*damp-type*] [**detail**]  
**damping** [*ip-prefix* | *prefix-length*] [**detail**]

**Context** show>router>bgp

**Description** This command displays BGP routes which have been dampened due to route flapping. This command can be entered with or without a route parameter.

When the keyword **detail** is included, more detailed information displays.

When only the command is entered (without any parameters included except **detail**), then all dampened routes are listed.

When a parameter is specified, then the matching route or routes are listed.

When a **decayed**, **history**, or **suppressed** keyword is specified, only those types of dampened routes are listed.

**Parameters** *ip-prefix* — Displays damping information for the specified IP prefix and length.

| Values | ip-v4-prefix        | a.b.c.d (host bits must be 0)       |
|--------|---------------------|-------------------------------------|
|        | ip-v4-prefix-length | 0 — 32                              |
|        | ip-v6-prefix        | x:x:x:x:x:x:x (eight 16-bit pieces) |
|        |                     | x:x:x:x:x:d.d.d.d                   |
|        |                     | x: [0 — FFFF]H                      |

## Show Commands

ipv6-prefix-length d: [0 — 255]D  
0 — 128

*damp-type* — Specifies the type of damping to display.

**Values** **decayed** — Displays damping entries that are decayed but are not suppressed.  
**history** — Displays damping entries that are withdrawn but have history. **suppressed** — Displays damping entries suppressed because of route damping.

**detail** — Displays detailed information.

**Output** **Damping Output Fields** — The following table describes BGP damping output fields.

| Label                    | Description                                                                                                                                                                           |
|--------------------------|---------------------------------------------------------------------------------------------------------------------------------------------------------------------------------------|
| BGP Router ID            | The local BGP router ID.                                                                                                                                                              |
| The local BGP router ID. | The configured autonomous system number.                                                                                                                                              |
| Local AS                 | The configured or inherited local AS for the specified peer group. If not configured, then it is the same value as the AS.                                                            |
| Network                  | Route IP prefix and mask length for the route.                                                                                                                                        |
| Flag(s)                  | Legend:<br>Status codes: u- used, s-suppressed, h-history, d-decayed, *-valid. If a * is not present, then the status is invalid.<br>Origin codes: i-IGP, e-EGP, ?-incomplete, >-best |
| From                     | The originator ID path attribute value.                                                                                                                                               |
| Reuse time               | The time when a suppressed route can be used again.                                                                                                                                   |
| From                     | The originator ID path attribute value.                                                                                                                                               |
| Reuse time               | The time when a suppressed route can be used again.                                                                                                                                   |
| AS Path                  | The BGP AS path for the route.                                                                                                                                                        |
| Peer                     | The router ID of the advertising router.                                                                                                                                              |
| NextHop                  | BGP nexthop for the route.                                                                                                                                                            |
| Peer AS                  | The autonomous system number of the advertising router.                                                                                                                               |
| Peer Router-Id           | The router ID of the advertising router.                                                                                                                                              |
| Local Pref               | BGP local preference path attribute for the route.                                                                                                                                    |
| Age                      | The length of time in hour/minute/second (HH:MM:SS) format.                                                                                                                           |
| Last update              | The time when BGP was updated last in day/hour/minute (DD:HH:MM) format.                                                                                                              |
| FOM Present              | The current Figure of Merit (FOM) value.                                                                                                                                              |
| Number of Flaps          | The number of route flaps in the neighbor connection.                                                                                                                                 |

| Label          | Description (Continued)                |
|----------------|----------------------------------------|
| Reuse time     | The time when the route can be reused. |
| Path           | The BGP AS path for the route.         |
| Applied Policy | The applied route policy name.         |

### Sample Output

```
A:ALA-12# show router bgp damping
=====
BGP Router ID : 10.0.0.14 AS : 65206 Local AS : 65206
=====
Legend -
Status codes : u - used, s - suppressed, h - history, d - decayed, * - valid
Origin codes : i - IGP, e - EGP, ? - incomplete, - best
=====
BGP Damped Routes
=====
Flag Network From Reuse AS-Path

ud*i 12.149.7.0/24 10.0.28.1 00h00m00s 60203 65001 19855 3356
 1239 22406
si 24.155.6.0/23 10.0.28.1 00h43m41s 60203 65001 19855 3356
 2914 7459
si 24.155.8.0/22 10.0.28.1 00h38m31s 60203 65001 19855 3356
 2914 7459
si 24.155.12.0/22 10.0.28.1 00h35m41s 60203 65001 19855 3356
 2914 7459
si 24.155.22.0/23 10.0.28.1 00h35m41s 60203 65001 19855 3356
 2914 7459
si 24.155.24.0/22 10.0.28.1 00h35m41s 60203 65001 19855 3356
 2914 7459
si 24.155.28.0/22 10.0.28.1 00h34m31s 60203 65001 19855 3356
 2914 7459
si 24.155.40.0/21 10.0.28.1 00h28m24s 60203 65001 19855 3356
 7911 7459
si 24.155.48.0/20 10.0.28.1 00h28m24s 60203 65001 19855 3356
 7911 7459
ud*i 61.8.140.0/24 10.0.28.1 00h00m00s 60203 65001 19855 3356
 4637 17447
ud*i 61.8.141.0/24 10.0.28.1 00h00m00s 60203 65001 19855 3356
 4637 17447
ud*i 61.9.0.0/18 10.0.28.1 00h00m00s 60203 65001 19855 3356
 3561 9658 6163
. . .
ud*i 62.213.184.0/23 10.0.28.1 00h00m00s 60203 65001 19855 3356
 6774 6774 9154
=====
A:ALA-12#
```

## Show Commands

```
A:ALA-12# show router bgp damping detail
=====
BGP Router ID : 10.0.0.14 AS : 65206 Local AS : 65206
=====
Legend -
Status codes : u - used, s - suppressed, h - history, d - decayed, * -
valid
Origin codes : i - IGP, e - EGP, ? - incomplete, - best
=====
BGP Damped Routes
=====

Network : 12.149.7.0/24

Network : 12.149.7.0/24 Peer : 10.0.28.1
NextHop : 10.0.28.1 Reuse time : 00h00m00s
Peer AS : 60203 Peer Router-Id : 32.32.27.203
Local Pref : none
Age : 00h22m09s Last update : 02d00h58m
FOM Present : 738 FOM Last upd. : 2039
Number of Flaps : 2 Flags : ud*i
Path : 60203 65001 19855 3356 1239 22406
Applied Policy : default-damping-profile

Network : 15.142.48.0/20

Network : 15.142.48.0/20 Peer : 10.0.28.1
NextHop : 10.0.28.1 Reuse time : 00h00m00s
Peer AS : 60203 Peer Router-Id : 32.32.27.203
Local Pref : none
Age : 00h00m38s Last update : 02d01h20m
FOM Present : 2011 FOM Last upd. : 2023
Number of Flaps : 2 Flags : ud*i
Path : 60203 65001 19855 3356 3561 5551 1889
Applied Policy : default-damping-profile

Network : 15.200.128.0/19

Network : 15.200.128.0/19 Peer : 10.0.28.1
NextHop : 10.0.28.1 Reuse time : 00h00m00s
Peer AS : 60203 Peer Router-Id : 32.32.27.203
Local Pref : none
Age : 00h00m38s Last update : 02d01h20m
FOM Present : 2011 FOM Last upd. : 2023
Number of Flaps : 2 Flags : ud*i
Path : 60203 65001 19855 1299 702 1889
Applied Policy : default-damping-profile

Network : 15.203.192.0/18

Network : 15.203.192.0/18 Peer : 10.0.28.1
NextHop : 10.0.28.1 Reuse time : 00h00m00s
Peer AS : 60203 Peer Router-Id : 32.32.27.203
Local Pref : none
Age : 00h00m07s Last update : 02d01h20m
FOM Present : 1018 FOM Last upd. : 1024
Number of Flaps : 1 Flags : ud*i
Path : 60203 65001 19855 1299 702 1889
Applied Policy : default-damping-profile
```

```

A:ALA-12#
A:ALA-12# show router bgp damping 15.203.192.0/18 detail
=====
BGP Router ID : 10.0.0.14 AS : 65206 Local AS : 65206
=====
Legend -
Status codes : u - used, s - suppressed, h - history, d - decayed, * - valid
Origin codes : i - IGP, e - EGP, ? - incomplete, - best
=====
BGP Damped Routes 15.203.192.0/18
=====
Network : 15.203.192.0/18

Network : 15.203.192.0/18 Peer : 10.0.28.1
NextHop : 10.0.28.1 Reuse time : 00h00m00s
Peer AS : 60203 Peer Router-Id : 32.32.27.203
Local Pref : none
Age : 00h00m42s Last update : 02d01h20m
FOM Present : 2003 FOM Last upd. : 2025
Number of Flaps : 2 Flags : ud*i
Path : 60203 65001 19855 3356 702 1889
Applied Policy : default-damping-profile

Paths : 1
=====
A:ALA-12#

```

```

A:ALA-12# show router bgp damping suppressed detail
=====
BGP Router ID : 10.0.0.14 AS : 65206 Local AS : 65206
=====
Legend -
Status codes : u - used, s - suppressed, h - history, d - decayed, * - valid
Origin codes : i - IGP, e - EGP, ? - incomplete, - best
=====
BGP Damped Routes (Suppressed)
=====
Network : 15.142.48.0/20

Network : 15.142.48.0/20 Peer : 10.0.28.1
NextHop : 10.0.28.1 Reuse time : 00h29m22s
Peer AS : 60203 Peer Router-Id : 32.32.27.203
Local Pref : none
Age : 00h01m28s Last update : 02d01h20m
FOM Present : 2936 FOM Last upd. : 3001
Number of Flaps : 3 Flags : si
Path : 60203 65001 19855 3356 702 1889
Applied Policy : default-damping-profile

Network : 15.200.128.0/19

Network : 15.200.128.0/19 Peer : 10.0.28.1
NextHop : 10.0.28.1 Reuse time : 00h29m22s
Peer AS : 60203 Peer Router-Id : 32.32.27.203
Local Pref : none

```

## Show Commands

```
Age : 00h01m28s Last update : 02d01h20m
FOM Present : 2936 FOM Last upd. : 3001
Number of Flaps : 3 Flags : si
Path : 60203 65001 19855 3356 702 1889
Applied Policy : default-damping-profile

Network : 15.203.240.0/20

Network : 15.203.240.0/20 Peer : 10.0.28.1
NextHop : 10.0.28.1 Reuse time : 00h29m22s
Peer AS : 60203 Peer Router-Id : 32.32.27.203
Local Pref : none
Age : 00h01m28s Last update : 02d01h20m
FOM Present : 2936 FOM Last upd. : 3001
Number of Flaps : 3 Flags : si
Path : 60203 65001 19855 3356 702 1889
Applied Policy : default-damping-profile

Network : 15.206.0.0/17

Network : 15.206.0.0/17 Peer : 10.0.28.1
NextHop : 10.0.28.1 Reuse time : 00h29m22s
Peer AS : 60203 Peer Router-Id : 32.32.27.203
Local Pref : none
Age : 00h01m28s Last update : 02d01h20m
FOM Present : 2936 FOM Last upd. : 3001
Number of Flaps : 3 Flags : si
Path : 60203 65001 19855 3356 702 1889
Applied Policy : default-damping-profile

A:ALA-12#
```

## group

**Syntax** `group [name] [detail]`

**Context** `show>router>bgp`

**Description** This command displays group information for a BGP peer group. This command can be entered with or without parameters.

When this command is entered without a group name, information about all peer groups displays.

When the command is issued with a specific group name, information only pertaining to that specific peer group displays.

The 'State' field displays the BGP group's operational state. Valid states are:

Up — BGP global process is configured and running.

Down — BGP global process is administratively shutdown and not running.

Disabled — BGP global process is operationally disabled. The process must be restarted by the operator.

**Parameters** `name` — Displays information for the BGP group specified.

`detail` — Displays detailed information.



**Output Standard and Detailed Group Output** — The following table describes the standard and detailed command output fields for a BGP group.

| Label            | Description                                                                                                                                                                |
|------------------|----------------------------------------------------------------------------------------------------------------------------------------------------------------------------|
| Group            | Displays the BGP group name.                                                                                                                                               |
| Group Type       | No Type — Peer type not configured.<br>External — Peer type configured as external BGP peers.<br>Internal — Peer type configured as internal BGP peers.                    |
| State            | Disabled — The BGP peer group has been operationally disabled.<br>Down — The BGP peer group is operationally inactive.<br>Up — The BGP peer group is operationally active. |
| Peer AS          | The configured or inherited peer AS for the specified peer group.                                                                                                          |
| Local AS         | The configured or inherited local AS for the specified peer group.                                                                                                         |
| Local Address    | The configured or inherited local address for originating peering for the specified peer group.                                                                            |
| Loop Detect      | The configured or inherited loop detect setting for the specified peer group.                                                                                              |
| Connect Retry    | The configured or inherited connect retry timer value.                                                                                                                     |
| Authentication   | None — No authentication is configured.<br>MD5 — MD5 authentication is configured.                                                                                         |
| Bfd              | Yes — BFD is enabled.<br>No — BFD is disabled.                                                                                                                             |
| Local Pref       | The configured or inherited local preference value.                                                                                                                        |
| MED Out          | The configured or inherited MED value assigned to advertised routes without a MED attribute.                                                                               |
| Min Route Advt.  | The minimum amount of time that must pass between route updates for the same IP prefix.                                                                                    |
| Min AS Originate | The minimum amount of time that must pass between updates for a route originated by the local router.                                                                      |
| Multihop         | The maximum number of router hops a BGP connection can traverse.                                                                                                           |
| Prefix Limit     | No Limit — No route limit assigned to the BGP peer group.<br>1 — 4294967295 — The maximum number of routes BGP can learn from a peer.                                      |

## Show Commands

| <b>Label</b>    | <b>Description (Continued)</b>                                                                                                                                                                                                                                                                    |
|-----------------|---------------------------------------------------------------------------------------------------------------------------------------------------------------------------------------------------------------------------------------------------------------------------------------------------|
| Passive         | Disabled – BGP attempts to establish a BGP connection with neighbor in the specified peer group.<br><br>Enabled – BGP will not actively attempt to establish a BGP connection with neighbor in the specified peer group.                                                                          |
| Next Hop Self   | Disabled – BGP is not configured to send only its own IP address as the BGP nexthop in route updates to neighbors in the peer group.<br><br>Enabled – BGP sends only its own IP address as the BGP nexthop in route updates to neighbors in the specified peer group.                             |
| Aggregator ID 0 | Disabled – BGP is not configured to set the aggregator ID to 0.0.0.0 in all originated route aggregates sent to the neighbor in the peer group.<br><br>Enabled – BGP is configured to set the aggregator ID to 0.0.0.0 in all originated route aggregates sent to the neighbor in the peer group. |
| Remove Private  | Disabled – BGP will not remove all private AS numbers from the AS path attribute in updates sent to the neighbor in the peer group.<br><br>Enabled – BGP removes all private AS numbers from the AS path attribute in updates sent to the neighbor in the peer group.                             |
| Damping         | Disabled – The peer group is configured not to dampen route flaps.<br><br>Enabled – The peer group is configured to dampen route flaps.                                                                                                                                                           |
| Export Policy   | The configured export policies for the peer group.                                                                                                                                                                                                                                                |
| Import Policy   | The configured import policies for the peer group.                                                                                                                                                                                                                                                |
| Hold Time       | The configured hold time setting.                                                                                                                                                                                                                                                                 |
| Keep Alive      | The configured keepalive setting.                                                                                                                                                                                                                                                                 |
| Cluster Id      | The configured route reflector cluster ID.<br><br>None – No cluster ID has been configured                                                                                                                                                                                                        |
| Client Reflect  | Disabled – The BGP route reflector will not reflect routes to this neighbor.<br><br>Enabled – The BGP route reflector is configured to reflect routes to this neighbor.                                                                                                                           |
| NLRI            | The type of NLRI information that the specified peer group can accept.<br><br>Unicast – IPv4 unicast routing information can be carried.                                                                                                                                                          |
| Preference      | The configured route preference value for the peer group.                                                                                                                                                                                                                                         |

| Label         | Description (Continued)                                     |
|---------------|-------------------------------------------------------------|
| List of Peers | A list of BGP peers configured under the peer group.        |
| Total Peers   | The total number of peers configured under the peer group.  |
| Established   | The total number of peers that are in an established state. |

### Sample Output

```
A:ALA-12# show router bgp group
=====
BGP Groups

Group : To_AS_40000

Description : Not Available
Group Type : No Type State : Up
Peer AS : 40000 Local AS : 65206
Local Address : n/a Loop Detect : Ignore
Export Policy : direct2bgp
Hold Time : 90 Keep Alive : 30
Cluster Id : None Client Reflect : Enabled
NLRI : Unicast Preference : 170

List of Peers
- 10.0.0.1 : To_Jukebox
- 10.0.0.12 : Not Available
- 10.0.0.13 : Not Available
- 10.0.0.14 : To_SR1
- 10.0.0.15 : To_H-215

Total Peers : 5 Established : 2
=====
A:ALA-12#
```

### Sample Detailed Output

```
A:ALA-12# show router bgp group detail
=====
BGP Groups (detail)

Group : To_AS_40000

Description : Not Available
Group Type : No Type State : Up
Peer AS : 40000 Local AS : 65206
Local Address : n/a Loop Detect : Ignore
Connect Retry : 20 Authentication : None
Local Pref : 100 MED Out : 0
Multihop : 0 (Default)
Min Route Advt. : 30 Min AS Originate : 15
Prefix Limit : No Limit Passive : Disabled
Next Hop Self : Disabled Aggregator ID 0 : Disabled
Remove Private : Disabled Damping : Disabled
Export Policy : direct2bgp
```

## Show Commands

```
Hold Time : 90 Keep Alive : 30
Cluster Id : None Client Reflect : Enabled
NLRI : Unicast Preference : 170

List of Peers
- 10.0.0.1 : To_Jukebox
- 10.0.0.12 : Not Available
- 10.0.0.13 : Not Available
- 10.0.0.14 : To_SR1
- 10.0.0.15 : To_H-215

Total Peers : 5 Established : 2
=====
A:ALA-12#

A:SetupCLI>show>router>bgp# group
=====
BGP Group

Group : bgp_group_1 34567890123456789012

Description : Testing the length of the group value for the DESCRIPTION
 parameter of BGP
Group Type : No Type State : Up
Peer AS : n/a Local AS : 100
Local Address : n/a Loop Detect : Ignore
Import Policy : test i1
 : test i2
 : test i3
 : test i4
 : test i5 890123456789012345678901
Export Policy : test e1
 : test e2
 : test e3
 : test e4
 : test e5 890123456789012345678901
Hold Time : 120 Keep Alive : 30
Cluster Id : None Client Reflect : Disabled
NLRI : Unicast Preference : 101
TTL Security : Disabled Min TTL Value : n/a
Graceful Restart : Disabled Stale Routes Time: n/a
Auth key chain : n/a Bfd Enabled : Yes

List of Peers
- 3.3.3.3 :
 Testing the length of the neighbor value for the DESCRIPTION parameter of
 BGP
Total Peers : 1 Established : 0

Peer Groups : 1
=====
A:SetupCLI>show>router>bgp#
```

## neighbor

**Syntax** **neighbor** [*ip-address* [**detail**]]  
**neighbor** [*as-number* [**detail**]]  
**neighbor** *ip-address* [*family* [**type** *mvpn-type*]] *filter1* [**brief**]  
**neighbor** *ip-address* [*family*] *filter2*  
**neighbor** *as-number* [*family*] *filter2*  
**neighbor** *ip-address* **orf** [*filter3*]  
**neighbor** *ip-address* **graceful-restart**

**Context** show>router>bgp

**Description** This command displays BGP neighbor information. This command can be entered with or without any parameters.

When this command is issued without any parameters, information about all BGP peers displays.

When the command is issued with a specific IP address or ASN, information regarding only that specific peer or peers with the same AS displays.

When either **received-routes** or **advertised-routes** is specified, then the routes received from or sent to the specified peer is listed (see second output example).

Note: This information is not available by SNMP.

When either **history** or **suppressed** is specified, then the routes learned from those peers that either have a history or are suppressed (respectively) are listed.

The 'State' field displays the BGP peer's protocol state. In addition to the standard protocol states, this field can also display the 'Disabled' operational state which indicates the peer is operationally disabled and must be restarted by the operator.

**Parameters** *ip-address* — Display information for the specified IP address.

**Values**      *ipv4-address:*      a.b.c.d (host bits must be 0)  
                  *ipv6-address:*      x:x:x:x:x:x[-interface]  
                                               x:x:x:x:x:d.d.d.d[-interface]  
                  x:                              [0 — FFFF]H  
                  d:                              [0 — 255]D  
                  interface: 32 characters maximum, mandatory for link local addresses.

*as-number* — Display information for the specified AS number.

**Values**      1 — 65535

**family** — Specify the type of routing information to be distributed by this peer group.

**Values**      **ipv4** — Displays only those BGP peers that have the IPv4 family enable and not those capable of exchanging IP-VPN routes.  
                  **vpn-ipv4** — Displays the content of the multicast routing table.  
                  **ipv6** — Displays the BGP peers that are IPv6 capable.  
                  **mcast-ipv4** — Displays the BGP peers that are mcast-ipv4 capable.

## Show Commands

*filter1* — Display information for the specified IP address.

**Values**

- received-routes** — Displays the number of routes received from this peer.
- advertised-routes** — Displays the number of routes advertised by this peer.
- history** — Displays statistics for dampened routes.
- suppressed** — Displays the number of paths from this peer that have been suppressed by damping.
- detail** — Displays detailed information pertaining to *filter1*.

*filter2* — Display information for the specified AS number.

**Values**

- history** — Display statistics for dampened routes.
- suppressed** — Display the number of paths from this peer that have been suppressed by damping.
- detail** — Displays detailed information pertaining to *filter2*.

*filter3* — Displays path information for the specified IP address.

**Values**

- send** — Displays the number of paths sent to this peer.
- receive** — Displays the number of paths received from this peer.

**brief** — Displays information in a brief format. This parameter is only supported with received-routes and advertised-routes.

**orf** — Displays outbound route filtering for the BGP instance. ORF (Outbound Route Filtering) is used to inform a neighbor of targets (using target-list) that it is willing to receive. This mechanism helps lessen the update exchanges between neighbors and saves CPU cycles to process routes that could have been received from the neighbor only to be dropped/ignored.

**graceful-restart** — Displays neighbors configured for graceful restart.

### Output

**Standard and Detailed Neighbor** — The following table describes the standard and detailed command output fields for a BGP neighbor.

| Label         | Description                                                                                                      |
|---------------|------------------------------------------------------------------------------------------------------------------|
| Peer          | The IP address of the configured BGP peer.                                                                       |
| Group         | The BGP peer group to which this peer is assigned.                                                               |
| Peer AS       | The configured or inherited peer AS for the peer group.                                                          |
| Peer Address  | The configured address for the BGP peer.                                                                         |
| Peer Port     | The TCP port number used on the far-end system.                                                                  |
| Local AS      | The configured or inherited local AS for the peer group.                                                         |
| Local Address | The configured or inherited local address for originating peering for the peer group.                            |
| Local Port    | The TCP port number used on the local system.                                                                    |
| Peer Type     | External — Peer type configured as external BGP peers.<br>Internal — Peer type configured as internal BGP peers. |

| Label      | Description (Continued)                                                                                                                                                                                                                                                                                                                                                                                                                                                                                                                                                   |
|------------|---------------------------------------------------------------------------------------------------------------------------------------------------------------------------------------------------------------------------------------------------------------------------------------------------------------------------------------------------------------------------------------------------------------------------------------------------------------------------------------------------------------------------------------------------------------------------|
| Bfd        | <p>Yes – BFD is enabled.</p> <p>No – BFD is disabled.</p>                                                                                                                                                                                                                                                                                                                                                                                                                                                                                                                 |
| State      | <p>Idle – The BGP peer is not accepting connections.</p> <p>Active – BGP is listening for and accepting TCP connections from this peer.</p> <p>Connect – BGP is attempting to establish a TCP connections from this peer.</p> <p>Open Sent – BGP has sent an OPEN message to the peer and is waiting for an OPEN message from the peer.</p> <p>Open Confirm – BGP has received a valid OPEN message from the peer and is awaiting a KEEPALIVE or NOTIFICATION.</p> <p>Established – BGP has successfully established a peering and is exchanging routing information.</p> |
| Last State | <p>Idle – The BGP peer is not accepting connections.</p> <p>Active – BGP is listening for and accepting TCP connections from this peer.</p> <p>Connect – BGP is attempting to establish a TCP connections from this peer.</p> <p>Open Sent – BGP has sent an OPEN message to the peer and is waiting for an OPEN message from the peer.</p> <p>Open Confirm – BGP has received a valid OPEN message from the peer and is awaiting a KEEPALIVE or NOTIFICATION.</p>                                                                                                        |
| Last Event | <p>start – BGP has initialized the BGP neighbor.</p> <p>stop – BGP has disabled the BGP neighbor.</p> <p>open – BGP transport connection opened.</p> <p>close – BGP transport connection closed.</p> <p>openFail – BGP transport connection failed to open.</p> <p>error – BGP transport connection error.</p> <p>connectRetry – Connect retry timer expired.</p> <p>holdTime – Hold time timer expired.</p> <p>keepAlive – Keepalive timer expired.</p> <p>recvOpen – Receive an OPEN message.</p>                                                                       |

## Show Commands

| <b>Label</b>      | <b>Description (Continued)</b>                                                                                                                                                                                                            |
|-------------------|-------------------------------------------------------------------------------------------------------------------------------------------------------------------------------------------------------------------------------------------|
|                   | revKeepalive – Receive a KEEPALIVE message.                                                                                                                                                                                               |
|                   | recvUpdate – Receive an UPDATE message.                                                                                                                                                                                                   |
|                   | recvNotify – Receive a NOTIFICATION message.                                                                                                                                                                                              |
|                   | None – No events have occurred.                                                                                                                                                                                                           |
| Last Error        | Displays the last BGP error and subcode to occur on the BGP neighbor.                                                                                                                                                                     |
| Connect Retry     | The configured or inherited connect retry timer value.                                                                                                                                                                                    |
| Local Pref.       | The configured or inherited local preference value.                                                                                                                                                                                       |
| Min Route Advt.   | The minimum amount of time that must pass between route updates for the same IP prefix.                                                                                                                                                   |
| Min AS Originate  | The minimum amount of time that must pass between updates for a route originated by the local router.                                                                                                                                     |
| Multihop          | The maximum number of router hops a BGP connection can traverse.                                                                                                                                                                          |
| Damping           | Disabled – BGP neighbor is configured not to dampen route flaps.<br>Enabled – BGP neighbor is configured to dampen route flaps.                                                                                                           |
| Loop Detect       | Ignore – The BGP neighbor is configured to ignore routes with an AS loop.<br>Drop – The BGP neighbor is configured to drop the BGP peering if an AS loop is detected.<br>Off – AS loop detection is disabled for the neighbor.            |
| MED Out           | The configured or inherited MED value assigned to advertised routes without a MED attribute.                                                                                                                                              |
| Authentication    | None – No authentication is configured.<br>MD5 – MD5 authentication is configured.                                                                                                                                                        |
| Next Hop Self     | Disabled – BGP is not configured to send only its own IP address as the BGP nexthop in route updates to the specified neighbor.<br>Enabled – BGP will send only its own IP address as the BGP nexthop in route updates to the neighbor.   |
| AggregatorID Zero | Disabled – The BGP Neighbor is not configured to set the aggregator ID to 0.0.0.0 in all originated route aggregates.<br>Enabled – The BGP Neighbor is configured to set the aggregator ID to 0.0.0.0 in all originated route aggregates. |



| Label             | Description (Continued)                                                                                                                                                                                                                                            |
|-------------------|--------------------------------------------------------------------------------------------------------------------------------------------------------------------------------------------------------------------------------------------------------------------|
| Remove Private    | <p>Disabled – BGP will not remove all private AS numbers from the AS path attribute, in updates sent to the specified neighbor.</p> <p>Enabled – BGP will remove all private AS numbers from the AS path attribute, in updates sent to the specified neighbor.</p> |
| Passive           | <p>Disabled – BGP will actively attempt to establish a BGP connection with the specified neighbor.</p> <p>Enabled – BGP will not actively attempt to establish a BGP connection with the specified neighbor.</p>                                                   |
| Prefix Limit      | <p>No Limit – No route limit assigned to the BGP peer group.</p> <p>1 — 4294967295 – The maximum number of routes BGP can learn from a peer.</p>                                                                                                                   |
| Hold Time         | The configured hold time setting.                                                                                                                                                                                                                                  |
| Keep Alive        | The configured keepalive setting.                                                                                                                                                                                                                                  |
| Active Hold Time  | The negotiated hold time, if the BGP neighbor is in an established state.                                                                                                                                                                                          |
| Active Keep Alive | The negotiated keepalive time, if the BGP neighbor is in an established state.                                                                                                                                                                                     |
| Cluster Id        | <p>The configured route reflector cluster ID.</p> <p>None – No cluster ID has been configured.</p>                                                                                                                                                                 |
| Client Reflect    | <p>Disabled – The BGP route reflector is configured not to reflect routes to this neighbor.</p> <p>Enabled – The BGP route reflector is configured to reflect routes to this neighbor.</p>                                                                         |
| Preference        | The configured route preference value for the peer group.                                                                                                                                                                                                          |
| Num of Flaps      | The number of route flaps in the neighbor connection..                                                                                                                                                                                                             |
| Recd. Prefixes    | The number of routes received from the BGP neighbor.                                                                                                                                                                                                               |
| Active Prefixes   | The number of routes received from the BGP neighbor and active in the forwarding table.                                                                                                                                                                            |
| Recd. Paths       | The number of unique sets of path attributes received from the BGP neighbor.                                                                                                                                                                                       |
| Suppressed Paths  | The number of unique sets of path attributes received from the BGP neighbor and suppressed due to route damping.                                                                                                                                                   |
| Input Queue       | The number of BGP messages to be processed.                                                                                                                                                                                                                        |

## Show Commands

| Label         | Description (Continued)                                 |
|---------------|---------------------------------------------------------|
| Output Queue  | The number of BGP messages to be transmitted.           |
| i/p Messages  | Total number of packets received from the BGP neighbor. |
| o/p Messages  | Total number of packets sent to the BGP neighbor.       |
| i/p Octets    | Total number of octets received from the BGP neighbor.  |
| o/p Octets    | Total number of octets sent to the BGP neighbor.        |
| Export Policy | The configured export policies for the peer group.      |
| Import Policy | The configured import policies for the peer group.      |

### Sample Output

```
A:ALA-48# show router bgp neighbor
=====
BGP Neighbor

Peer : 10.0.0.5 Group : headquarters1

Peer AS : 300 Peer Port : 0
Peer Address : 10.0.0.5
Local AS : 200 Local Port : 0
Local Address : 10.0.0.104
Peer Type : External
State : Active Last State : Idle
Last Event : stop
Last Error : Cease
Local Family : IPv4 Remote Family : Unused
Hold Time : 90 Keep Alive : 30
Active Hold Time : 0 Active Keep Alive: 0
Cluster Id : 0.0.0.100
Preference : 170 Num of Flaps : 0
Recd. Prefixes : 0 Active Prefixes : 0
Recd. Paths : 0 Suppressed Paths : 0
Input Queue : 0 Output Queue : 0
i/p Messages : 0 o/p Messages : 0
i/p Octets : 0 o/p Octets : 0
i/p Updates : 0 o/p Updates : 0
TTL Security : Enabled Min TTL Value : 255
Graceful Restart : Disabled Stale Routes Time: n/a
Local Capability : RouteRefresh MP-BGP
Remote Capability:
Import Policy : None Specified / Inherited
Export Policy : None Specified / Inherited

Peer : 10.0.0.91 Group : Santa Clara

Peer AS : 100 Peer Port : 0
Peer Address : 10.0.0.91
Local AS : 200 Local Port : 0
Local Address : 10.0.0.103
Peer Type : External
```

```

State : Connect Last State : Active
Last Event : openFail
Last Error : Cease
Local Family : IPv4 Remote Family : Unused
Hold Time : 90 Keep Alive : 30
Active Hold Time : 0 Active Keep Alive: 0
Cluster Id : 0.0.0.100
Preference : 170 Num of Flaps : 0
Recd. Prefixes : 0 Active Prefixes : 0
Recd. Paths : 0 Suppressed Paths : 0
Input Queue : 0 Output Queue : 0
i/p Messages : 0 o/p Messages : 1
i/p Octets : 0 o/p Octets : 0
i/p Updates : 0 o/p Updates : 0
TTL Security : Disabled Min TTL Value : n/a
Graceful Restart : Disabled Stale Routes Time: n/a
Local Capability : RouteRefresh MP-BGP
Remote Capability:
Import Policy : None Specified / Inherited
Export Policy : None Specified / Inherited
...

```

```

A:ALA-48#
```

```
A:ALA-48# show router 2 bgp neighbor 10.20.1.3
```

```
=====
BGP Neighbor
=====
```

```
Peer : 10.20.1.3
Group : 1

```

```

Peer AS : 100 Peer Port : 49725
Peer Address : 10.20.1.3
Local AS : 100 Local Port : 179
Local Address : 10.20.1.2
Peer Type : Internal
State : Established Last State : Established
Last Event : recvKeepAlive
Last Error : Cease
Local Family : IPv4
Remote Family : IPv4
Hold Time : 3 Keep Alive : 1
Active Hold Time : 3 Active Keep Alive : 1
Cluster Id : None
Preference : 170 Num of Flaps : 0
Recd. Paths : 1
IPv4 Recd. Prefixes : 11 IPv4 Active Prefixes : 10
VPN-IPv4 Recd. Pfxs : 0 VPN-IPv4 Suppr. Pfxs : 0
VPN-IPv4 Active Pfxs : 0 VPN-IPv4 Active Pfxs : 0
Mc IPv4 Recd. Pfxs. : 0 Mc IPv4 Active Pfxs. : 0
Mc IPv4 Suppr. Pfxs : 0 IPv6 Suppressed Pfxs : 0
IPv6 Recd. Prefixes : 0 IPv6 Active Prefixes : 0
Input Queue : 0 Output Queue : 0
i/p Messages : 471 o/p Messages : 473
i/p Octets : 3241 o/p Octets : 3241
i/p Updates : 4 o/p Updates : 4
TTL Security : Disabled Min TTL Value : n/a
Advertise Inactive : Disabled Peer Tracking : Disabled
Advertise Label : None

```

## Show Commands

```
Auth key chain : eta_keychain1
Local Capability : RouteRefresh MP-BGP
Remote Capability : RouteRefresh MP-BGP
Import Policy : None Specified / Inherited
Export Policy : static2bgp

Neighbors : 1
=====
A:ALA-48#

A:ALA-12# show router bgp neighbor 10.0.0.11 orf
=====
BGP Neighbor 10.0.0.11 ORF
=====
Send List (Automatic)

target:65535:10
target:65535:20
=====
A:ALA-12

A:ALA-22 show router bgp neighbor 10.0.0.1 orf
=====
BGP Neighbor 10.0.0.1 ORF
=====
Receive List

target:65535:10
target:65535:20
=====
A:ALA-22
```

### Sample Detailed Output

```
A:ALA-12# show router bgp neighbor detail
=====
BGP Neighbor (detail)

Peer : 10.0.0.15 Group : To_AS_40000

Peer AS : 65205 Peer Port : 0
Peer Address : 10.0.0.15 Local Port : 0
Local AS : 65206 Local Port : 0
Local Address : 10.0.0.16
Peer Type : External
State : Active Last State : Connect
Last Event : openFail
Last Error : Hold Timer Expire
Connect Retry : 20 Local Pref. : 100
Min Route Advt. : 30 Min AS Orig. : 15
Damping : Disabled Loop Detect : Ignore
MED Out : No MED Out Authentication : None
Next Hop Self : Disabled AggregatorID Zero: Disabled
Remove Private : Disabled Passive : Disabled
Prefix Limit : No Limit
Hold Time : 90 Keep Alive : 30
```

```

Active Hold Time : 0
Cluster Id : None
Preference : 170
Recd. Prefixes : 0
Recd. Paths : 0
Input Queue : 0
i/p Messages : 0
i/p Octets : 0
i/p Updates : 0
Export Policy : direct2bgp

Active Keep Alive: 0
Client Reflect : Enabled
Num of Flaps : 0
Active Prefixes : 0
Suppressed Paths : 0
Output Queue : 0
o/p Messages : 0
o/p Octets : 0
o/p Updates : 0

```

```

=====
A:ALA-12#

```

```

*A:SetupCLI>show>router>bgp# neighbor

```

```

=====
BGP Neighbor

```

```

Peer : 3.3.3.3

```

```

Group : bgp_group_1 34567890123456789012

```

```

Peer AS : 20 Peer Port : 0
Peer Address : 3.3.3.3
Local AS : 100 Local Port : 0
Local Address : 0.0.0.0
Peer Type : Internal
State : Active Last State : Idle
Last Event : stop
Last Error : Cease
Local Family : IPv4
Remote Family : Unused
Hold Time : 10 Keep Alive : 30
Active Hold Time : 0 Active Keep Alive : 0
Cluster Id : 2.2.3.4
Preference : 101 Num of Flaps : 0
Recd. Paths : 0
IPv4 Recd. Prefixes : 0 IPv4 Active Prefixes : 0
IPv4 Suppressed Pfxs : 0 VPN-IPv4 Suppr. Pfxs : 0
VPN-IPv4 Recd. Pfxs : 0 VPN-IPv4 Active Pfxs : 0
Mc IPv4 Recd. Pfxs : 0 Mc IPv4 Active Pfxs : 0
Mc IPv4 Suppr. Pfxs : 0 IPv6 Suppressed Pfxs : 0
IPv6 Recd. Prefixes : 0 IPv6 Active Prefixes : 0
Input Queue : 0 Output Queue : 0
i/p Messages : 0 o/p Messages : 0
i/p Octets : 0 o/p Octets : 0
i/p Updates : 0 o/p Updates : 0
TTL Security : Disabled Min TTL Value : n/a
Graceful Restart : Enabled Stale Routes Time : 360
Advertise Inactive : Disabled Peer Tracking : Enabled
Advertise Label : None Bfd Enabled : Yes
Auth key chain : n/a
Local Capability : RouteRefresh MP-BGP
Remote Capability :
Import Policy : test i1
: test i2
: test i3
: test i4
: test i5 890123456789012345678901
Export Policy : test e1

```

## Show Commands

```
: test e2
: test e3
: test e4
: test e5 890123456789012345678901
```

```

Neighbors : 1
=====
```

**Advertised and Received Routes Ouput** — The following table describes the command output for both the standard and detailed information for a neighbor.

| Label         | Description                                                                                                               |
|---------------|---------------------------------------------------------------------------------------------------------------------------|
| BGP Router ID | The local BGP router ID.                                                                                                  |
| AS            | The configured autonomous system number.                                                                                  |
| Local AS      | The configured local AS setting. If not configured, then it is the same value as the AS.                                  |
| Flag          | u – used<br>s – suppressed<br>h – history<br>d – decayed<br>* – valid<br>i – igp<br>e – egp<br>? – incomplete<br>> – best |
| Network       | Route IP prefix and mask length for the route.                                                                            |
| Next Hop      | BGP nexthop for the route.                                                                                                |
| LocalPref     | BGP local preference path attribute for the route.                                                                        |
| MED           | BGP Multi-Exit Discriminator (MED) path attribute for the route.                                                          |
| AS Path       | The BGP AS path for the route.                                                                                            |

### Sample Output

```
A:ALA-12# show router bgp neighbor 10.0.0.16 received-routes
=====
BGP Router ID : 10.0.0.16 AS : 65206 Local AS : 65206
=====
Legend -
Status codes : u - used, s - suppressed, h - history, d - decayed, * - valid
```

```

Origin codes : i - IGP, e - EGP, ? - incomplete, > - best
=====
BGP Neighbor
=====
Flag Network Nexthop LocalPref MED As-Path

? 10.0.0.16/32 10.0.0.16 100 none No As-Path
? 10.0.6.0/24 10.0.0.16 100 none No As-Path
? 10.0.8.0/24 10.0.0.16 100 none No As-Path
? 10.0.12.0/24 10.0.0.16 100 none No As-Path
? 10.0.13.0/24 10.0.0.16 100 none No As-Path
? 10.0.204.0/24 10.0.0.16 100 none No As-Path
=====
A:ALA-12#

A:core_east# show router bgp neighbor 10.193.0.10 graceful-restart
=====
BGP Neighbor 10.193.0.10 Graceful Restart
=====
Graceful Restart locally configured for peer: Enabled
Peer's Graceful Restart feature : Enabled
NLRI(s) that peer supports restart for : IPv4-Unicast IPv4-MPLS IPv4-VPN
NLRI(s) that peer saved forwarding for : IPv4-Unicast IPv4-MPLS IPv4-VPN
NLRI(s) that restart is negotiated for : None
NLRI(s) of received end-of-rib markers : IPv4-Unicast
NLRI(s) of all end-of-rib markers sent : IPv4-Unicast
Restart time locally configured for peer : 120 seconds
Restart time requested by the peer : 390 seconds
Time stale routes from peer are kept for : 360 seconds
Graceful restart status on the peer : Not currently being helped
Number of Restarts : 328
Last Restart at : 08/20/2006 12:22:06
=====
A:core_east#

```

## next-hop

**Syntax** `next-hop [ family ] [ ip-address ] [ detail ]`

**Context** `show>router>bgp`

**Description** Displays BGP next-hop information.

**Parameters** **family** — Specify the type of routing information to be distributed by the BGP instance.

**Values**

- ipv4** — Displays only those BGP peers that have the IPv4 family enable and not those capable of exchanging IP-VPN routes.
- vpn-ipv4** — Displays the BGP peers that are IP-VPN capable.
- ipv6** — Displays the BGP peers that are IPv6 capable.
- mcast-ipv4** — Displays the BGP peers that are mcast-ipv4 capable.

*ip-address* — Displays the next hop information for the specified IP address.

**Values**

- ipv4-address: a.b.c.d (host bits must be 0)
- ipv6-address: x:x:x:x:x:x:x (eight 16-bit pieces)

## Show Commands

x:x:x:x:x:d.d.d.d  
 x [0 — FFFF]H  
 d [0 — 255]D

**detail** — Display the longer, more detailed version of the output.

**Output Show Next-Hop Output** — The following table describes the command output fields for a BGP next hop.

| Label             | Description                                                                               |
|-------------------|-------------------------------------------------------------------------------------------|
| BGP ID            | The local BGP router ID.                                                                  |
| AS                | The configured autonomous system number.                                                  |
| Local AS          | The configured local AS setting. If not configured, then the value is the same as the AS. |
| Next Hop          | The next-hop address.                                                                     |
| Resolving Prefix  | Displays the prefix of the best next hop.                                                 |
| Owner             | Displays the routing protocol used to derive the best next hop.                           |
| Preference        | Displays the BGP preference attribute for the routes.                                     |
| Reference Count   | Displays the number of routes using the resolving prefix.                                 |
| Resolved Next Hop | The IP address of the next hop.                                                           |

### Sample Output

```
*A:Dut-C# show router bgp next-hop
=====
BGP Router ID:10.20.1.3 AS:5000 Local AS:5000
=====

BGP Next Hop
=====
Next Hop Pref Owner
 Resolving Prefix Metric
 Resolved Next Hop Ref. Count

10.20.1.1 7 RSVP
 10.20.1.1/32 1000
 10.10.2.1 2
10.20.1.2 7 RSVP
 10.20.1.2/32 1000
 10.10.3.2 2
10.20.1.4 7 RSVP
 10.20.1.4/32 1000
 10.10.11.4 2

Next Hops : 3
```



```

A:ALA-49>show>router>bgp# next-hop 192.168.2.194

BGP Router ID : 10.10.10.104 AS : 200 Local AS : 200
=====
BGP Next Hop

Next Hop Resolving Owner Preference Reference Resolved
 Prefix
 Count Next Hop

A:ALA-49>show>router>bgp# next-hop 10.10.10.104

```

## paths

**Syntax** paths

**Context** show>router>bgp

**Description** This command displays a summary of BGP path attributes.

**Output** **Show Path Output** — The following table describes the command output fields for a BGP path.

| Label            | Description                                                                                                                                                                         |
|------------------|-------------------------------------------------------------------------------------------------------------------------------------------------------------------------------------|
| BGP Router ID    | The local BGP router ID.                                                                                                                                                            |
| AS               | The configured autonomous system number.                                                                                                                                            |
| Local AS         | The configured local AS setting. If not configured, then the value is the same as the AS.                                                                                           |
| Path             | The AS path attribute.                                                                                                                                                              |
| Origin           | EGP — The NLRI is learned by an EGP protocol.<br>IGP — The NLRI is interior to the originating AS.<br>INCOMPLETE — NLRI was learned another way.                                    |
| Next Hop         | The advertised BGP nexthop.                                                                                                                                                         |
| MED              | The Multi-Exit Discriminator value.                                                                                                                                                 |
| Local Preference | The local preference value. This value is used if the BGP route arrives from a BGP peer without the Local Pref attribute set. It is overridden by any value set via a route policy. |
| Refs             | The number of routes using a specified set of path attributes.                                                                                                                      |
| ASes             | The number of autonomous system numbers in the AS path attribute.                                                                                                                   |
| Segments         | The number of segments in the AS path attribute.                                                                                                                                    |
| Flags            | EBGP-learned — Path attributes learned by an EBGP peering.<br>IBGP-Learned — Path attributes learned by an IBGP peering.                                                            |

## Show Commands

| <b>Label</b>  | <b>Description (Continued)</b>          |
|---------------|-----------------------------------------|
| Aggregator    | The route aggregator ID.                |
| Community     | The BGP community attribute list.       |
| Originator ID | The originator ID path attribute value. |
| Cluster List  | The route reflector cluster list.       |

### Sample Output

```
=====
BGP Router ID : 10.0.0.14 AS : 65206 Local AS : 65206
=====
BGP Paths
=====
Path: 60203 65001 19855 3356 15412

Origin : IGP Next Hop : 10.0.28.1
MED : 60203 Local Preference : none
Refs : 4 ASes : 5
Segments : 1
Flags : EBGP-learned
Aggregator : 15412 62.216.140.1

Path: 60203 65001 19855 3356 1 1236 1236 1236 1236

Origin : IGP Next Hop : 10.0.28.1
MED : 60203 Local Preference : none
Refs : 2 ASes : 9
Segments : 1
Flags : EBGP-learned
```

## route-target

**Syntax** route-target

**Context** show>router>bgp

**Description** This command displays a summary of route-target.

### Sample Output

```
*A:Dut-D# show router bgp routes route-target
=====
BGP Router ID:10.20.1.4 AS:100 Local AS:100
=====
```

```

Legend -
Status codes : u - used, s - suppressed, h - history, d - decayed, * - valid
Origin codes : i - IGP, e - EGP, ? - incomplete, > - best, b - backup

=====
BGP RT Constrain Routes
=====
Flag Route Target LocalPref MED
 Nexthop
 As-Path

u*? 0:0:0/0 None 0
 10.10.9.6
 106 106

Routes : 1
=====

```

## routes

**Syntax**

```

routes [family] [brief]
routes [family] prefix [detail | longer | hunt [brief]]
routes family prefix [detail | longer | hunt [brief]]
routes [family] [type mvpn-type] community comm-id
routes [family] [type mvpn-type] aspath-regex reg-ex
routes mvpn-ipv4 type mvpn-type {rd rd | originator-ip ip-address | source-ip ip-address |
group-ip ip-address | source-as as-number} [hunt| detail]
routes [family] [l2vpn-type] [brief]
routes [family] [l2vpn-type] community comm-id
routes [family] [l2vpn-type] aspath-regex reg-ex
routes l2-vpn l2vpn-type {[rd rd] | [siteid site-id] | [veid veid] [offset vpls-base-offset]}
routes mdt-safi [rd rd] [grp-address mcast-grp-address] [brief]
routes ms-pw [rd rd] [aII-type2 aII-type2] [brief]
routes flow-ipv4

```

**Context** show>router>bgp

**Description** This command displays BGP route information.

When this command is issued without any parameters, then the entire BGP routing table displays.

When this command is issued with an IP prefix/mask or IP address, then the best match for the parameter displays.

**Parameters** **family** — Specify the type of routing information to be distributed by the BGP instance.

**Values**

- ipv4** — Displays only those BGP peers that have the IPv4 family enable and not those capable of exchanging IP-VPN routes.
- vpn-ipv4** — Displays the BGP peers that are IP-VPN capable.
- ipv6** — Displays the BGP peers that are IPv6 capable.
- mcast-ipv4** — Displays the BGP peers that are mcast-ipv4 capable.

**received** — Specifies to show the BGP routes received from the neighbor,

## Show Commands

*prefix* — Specifies the type of routing information to display.

|               |                                                                                                                                                                                                                                                                                                                                                                                                                                                                                                                                                            |
|---------------|------------------------------------------------------------------------------------------------------------------------------------------------------------------------------------------------------------------------------------------------------------------------------------------------------------------------------------------------------------------------------------------------------------------------------------------------------------------------------------------------------------------------------------------------------------|
| <b>Values</b> | <b>Syntax:</b> <rd>[[<rd>:]<ip-prefix[/ip-prefix-length]><br>rd {<ip-addr:comm-val> <2byte-asnumber:ext-comm-val> <4byte-asnumber:comm-val>}<br>comm-val [0..65535]<br>2byte-asnumber [0..65535]<br>ext-comm-val [0..4294967295]<br>4byte-asnumber asn1.asn2 (two 2-byte pieces)<br>asn1 - [1..65535]<br>asn2 - [0..65535]<br>ip-address a.b.c.d<br>ipv4-prefix a.b.c.d<br>ipv4-prefix-le [0..32]<br>ipv6-prefix[/pref* ipv6-prefix x:x:x:x:x:x:x (eight 16-bit pieces)<br>x:x:x:x:x:x:d.d.d.d<br>x: [0 — FFFF]H<br>d: [0 — 255]D<br>prefix-length 0 — 128 |
|---------------|------------------------------------------------------------------------------------------------------------------------------------------------------------------------------------------------------------------------------------------------------------------------------------------------------------------------------------------------------------------------------------------------------------------------------------------------------------------------------------------------------------------------------------------------------------|

*filter* — Specifies route criteria.

|               |                                                                                       |
|---------------|---------------------------------------------------------------------------------------|
| <b>Values</b> | <b>hunt</b> Displays entries for the specified route in the RIB-In, RIB-Out, and RTM. |
|               | <b>longer</b> Displays the specified route and subsets of the route.                  |
|               | <b>detail</b> Display the longer, more detailed version of the output.                |

**aspath-regex** “*reg-exp*” — Displays all routes with an AS path matching the specified regular expression *reg-exp*.

**community** *comm.-id* — Displays all routes with the specified BGP community.

|                 |                                                                             |
|-----------------|-----------------------------------------------------------------------------|
| <b>Values</b>   | [ <i>as-number1:comm-val1</i>   <i>ext-comm</i>   <i>well-known-comm</i> ]  |
| ext-comm        | type: {ip-address:comm-val1   as-number1:comm-val2   as-number2:comm-val1 } |
| as-number1      | 0 — 65535                                                                   |
| comm-val1       | 0 — 65535                                                                   |
| type            | target, origin                                                              |
| ip-address      | a.b.c.d                                                                     |
| comm-val2       | 0 — 4294967295                                                              |
| as-number2      | 0 — 4294967295                                                              |
| well-known-comm | no-export, no-export-subconfed, no-advertise                                |

**brief** — Provides a summarized display of the set of peers to which a BGP route is advertised.

*rd* — Specifies the route distinguisher.

|               |                                                                             |
|---------------|-----------------------------------------------------------------------------|
| <b>Values</b> | ip-addr:comm-val<br>2byte-asnumber:ext-comm-val<br>4byte-asnumber:comm-val} |
|---------------|-----------------------------------------------------------------------------|

*veid* — Specifies a two byte identifier that represents the local bridging instance in a VPLS and is advertised through the BGP NLRI. This value must be lower than or equal to the max-ve-id.

|               |                |
|---------------|----------------|
| <b>Values</b> | 0 — 4294967295 |
|---------------|----------------|

*vpls-base-offset* — Specifies a two byte identifier advertised through the NLRI that is used to indicate which VE-ID should use the advertised NLRI at the receiving PE according to the following rule: if the  $\text{offset} \leq \text{local VE-ID} \leq \text{offset} + \text{VBS} - 1$  (VBS = virtual block size = 8 in our implementation) then the NLRI is processed. Otherwise it is ignored. The NLRI with this offset is generated as soon as the first VE-ID value between (offset, offset + VBS-1) is advertised in the network.

**Values** 0 — 4294967295

*site-id* — Specifies a two byte identifier usually employed for the BGP multi-homing solution. It identifies the BGP multi-homing site associated with one or a set of objects (SAP(s), pseudowire (s) or combination). The site-id must be identical between the two PEs carrying the connection to the access device multi-homed to the PEs.

**Values** 0 — 4294967295

*l2vpn-type* — Specifies a 12-byte Virtual Switch Instance identifier (VSI-ID) type.

**Values** bgp-ad, bgp-vpls, multi-homing

**ms-pw [rd rd] [aii-type2 aii-type2] [brief]** — Displays routes for ms-pw family.

**Output BGP Route** — The following table describes the command output fields for BGP routes.

| Label         | Description                                                                                                                                                                         |
|---------------|-------------------------------------------------------------------------------------------------------------------------------------------------------------------------------------|
| BGP Router ID | The local BGP router ID.                                                                                                                                                            |
| AS            | The configured autonomous system number.                                                                                                                                            |
| Local AS      | The configured local AS setting. If not configured, then the value is the same as the AS.                                                                                           |
| Route Dist.   | Displays the route distinguisher identifier attached to routes that distinguishes the VPN it belongs.                                                                               |
| VPN Label     | Displays the label generated by the PE's label manager.                                                                                                                             |
| Network       | The IP prefix and mask length.                                                                                                                                                      |
| Nexthop       | The BGP nexthop.                                                                                                                                                                    |
| From          | The advertising BGP neighbor's IP address.                                                                                                                                          |
| Res. Nexthop  | The resolved nexthop.                                                                                                                                                               |
| Local Pref.   | The local preference value. This value is used if the BGP route arrives from a BGP peer without the Local Pref attribute set. It is overridden by any value set via a route policy. |
| Flag          | u — used<br>s — suppressed                                                                                                                                                          |

## Show Commands

| Label          | Description (Continued)                                                                            |
|----------------|----------------------------------------------------------------------------------------------------|
|                | h — history                                                                                        |
|                | d — decayed                                                                                        |
|                | * — valid                                                                                          |
|                | i — igp                                                                                            |
|                | e — egp                                                                                            |
|                | ? — incomplete                                                                                     |
|                | > — best                                                                                           |
| Aggregator AS  | The aggregator AS value.<br>none — Aggregator AS attributes are not present.                       |
| Aggregator     | The aggregator attribute value.<br>none — Aggregator attributes are not present.                   |
| Atomic Aggr.   | Atomic — The atomic aggregator flag is set.<br>Not Atomic — The atomic aggregator flag is not set. |
| MED            | The MED metric value.<br>none — MED metrics are present.                                           |
| Community      | The BGP community attribute list.                                                                  |
| Cluster        | The route reflector cluster list.                                                                  |
| Originator Id  | The originator ID path attribute value.<br>none — The originator ID attribute is not present.      |
| Peer Router Id | The router ID of the advertising router.                                                           |
| AS-Path        | The BGP AS path attribute.                                                                         |
| VPRN Imported  | Displays the VPRNs where a particular BGP-VPN received route has been imported and installed.      |

### Sample Output

```
*A:Dut-C# show router bgp routes l2-vpn detail
=====
BGP Router ID:10.20.1.3 AS:1000 Local AS:1000
=====
```

Legend -

Status codes : u - used, s - suppressed, h - history, d - decayed, \* - valid

Origin codes : i - IGP, e - EGP, ? - incomplete, > - best, b - backup

=====

BGP L2VPN Routes

=====

Route Type : AutoDiscovery

Route Dist. : 10.20.1.1:1

Prefix : 10.20.1.1

Nexthop : 10.20.1.1

From : 10.20.1.1

Res. Nexthop : n/a

Local Pref. : 100 Interface Name : NotAvailable

Aggregator AS : None Aggregator : None

Atomic Aggr. : Not Atomic MED : 0

AIGP Metric : Not Atomic

Community : target:4455:4455 target:1.20.30.40:6543  
l2-vpn/vrf-imp:100.1.200.1:65535

Cluster : No Cluster Members

Originator Id : None Peer Router Id : 10.20.1.1

Flags : Used Valid Best IGP

Route Source : Internal

AS-Path : No As-Path

-----

PMSI Tunnel Attribute :

Tunnel-type : RSVP-TE P2MP LSP Flags : Leaf not required

MPLS Label : 0

P2MP-ID : 1001 Tunnel-ID : 61440

Extended-Tunne\*: 10.20.1.1

## Show Commands

```
*A:Dut-C# show router bgp routes hunt 1.1.1.1/32
=====
BGP Router ID:10.20.1.3 AS:5000 Local AS:5000
=====
Legend -
Status codes : u - used, s - suppressed, h - history, d - decayed, * - valid Origin codes
: i - IGP, e - EGP, ? - incomplete, > - best

=====
BGP IPv4 Routes
=====

RIB In Entries

Network : 1.1.1.1/32
Nextthop : 10.20.1.1
From : 10.20.1.1
Res. Nextthop : 10.20.1.1 (RSVP LSP: 1)
Local Pref. : 100
Aggregator AS : None
Atomic Aggr. : Not Atomic
Community : No Community Members
Cluster : No Cluster Members
Originator Id : None
Flags : Used Valid Best Incomplete
AS-Path : No As-Path
Interface Name : ip-10.10.2.3
Aggregator : None
MED : None
Peer Router Id : 10.20.1.1

RIB Out Entries

Routes : 1
=====

A:ALA-12>config>router>bgp# show router bgp routes family ipv4
=====
BGP Router ID : 10.10.10.103 AS : 200 Local AS : 200
=====
Legend -
Status codes : u - used, s - suppressed, h - history, d - decayed, * - valid
Origin codes : i - IGP, e - EGP, ? - incomplete, > - best
=====
BGP Routes
=====
Flag Network Nextthop LocalPref MED
 VPN Label As-Path

No Matching Entries Found
=====
A:ALA-12>config>router>bgp#

A:ALA-12>config>router>bgp# show router bgp routes 13.1.0.0/24 de
=====
BGP Router ID : 10.128.0.161 AS : 65535 Local AS : 65535
=====
```



Legend - Status codes : u - used, s - suppressed, h - history, d - decayed, \* - valid Origin codes : i - IGP, e - EGP, ? - incomplete, > - best

=====

BGP Routes

=====

Original Attributes

|                |                       |                |              |
|----------------|-----------------------|----------------|--------------|
| Network        | : 13.1.0.0/24         | NextHop        | : 10.20.1.20 |
| Route Dist.    | : 10070:100           | VPN Label      | : 152784     |
| From           | : 10.20.1.20          | Res. NextHop   | : 10.130.0.2 |
| Local Pref.    | : 100                 |                |              |
| Aggregator AS: | none                  | Aggregator     | : none       |
| Atomic Aggr.   | : Not Atomic          | MED            | : none       |
| Community      | : target:10070:1      |                |              |
| Cluster        | : No Cluster Members  |                |              |
| Originator Id: | None                  | Peer Router Id | : 10.20.1.20 |
| Flags          | : Used Valid Best IGP |                |              |
| AS-Path        | : 10070 {14730}       |                |              |

Modified Attributes

|                |                       |                |              |
|----------------|-----------------------|----------------|--------------|
| Network        | : 13.1.0.0/24         | NextHop        | : 10.20.1.20 |
| Route Dist.    | : 10001:100           | VPN Label      | : 152560     |
| From           | : 10.20.1.20          | Res. NextHop   | : 10.130.0.2 |
| Local Pref.    | : 100                 |                |              |
| Aggregator AS: | none                  | Aggregator     | : none       |
| Atomic Aggr.   | : Not Atomic          | MED            | : none       |
| Community      | : target:10001:1      |                |              |
| Cluster        | : No Cluster Members  |                |              |
| Originator Id: | None                  | Peer Router Id | : 10.20.1.20 |
| Flags          | : Used Valid Best IGP |                |              |
| AS-Path        | : No As-Path          |                |              |

.....

=====

A:ALA-12>config>router>bgp#

A:SR-12# show router bgp routes 100.0.0.0/30 hunt

=====

BGP Router ID : 10.20.1.1 AS : 100Local AS : 100

=====

Legend -

Status codes : u - used, s - suppressed, h - history, d - decayed, \* - valid  
Origin codes : i - IGP, e - EGP, ? - incomplete, > - best

=====

BGP Routes

=====

RIB In Entries

-----

|               |                      |                 |          |
|---------------|----------------------|-----------------|----------|
| Network       | : 100.0.0.0/30       |                 |          |
| NextHop       | : 10.20.1.2          |                 |          |
| Route Dist.   | : 10.20.1.2:1        | VPN Label       | : 131070 |
| From          | : 10.20.1.2          |                 |          |
| Res. NextHop  | : 10.10.1.2          |                 |          |
| Local Pref.   | : 100                | Interface Name: | to-sr7   |
| Aggregator AS | : none               | Aggregator      | : none   |
| Atomic Aggr.  | : Not Atomic         | MED             | : none   |
| Community     | : target:10.20.1.2:1 |                 |          |
| Cluster       | : No Cluster Members |                 |          |

## Show Commands

```

Originator Id : None Peer Router Id: 10.20.1.2
Flags : Used Valid Best IGP
AS-Path : No As-Path
VPRN Imported : 1 2 10 12

RIB Out Entries

Routes : 1
=====
A:SR-12#

*A:praragon-siml# /show router bgp routes mvpn-ipv4
=====
BGP Router ID:10.20.1.3 AS:200 Local AS:200
=====
Legend -
Status codes : u - used, s - suppressed, h - history, d - decayed, * - valid
Origin codes : i - IGP, e - EGP, ? - incomplete, > - best
=====
BGP MVPN-IPv4 Routes
=====
Flag RouteType OriginatorIP LocalPref MED VPNLabel
RD SourceAS
Nexthop SourceIP
As-Path GroupIP

u*>i Intra-Ad 10.20.1.4 100 0
1:1 - -
10.20.1.4 - -
No As-Path - -
u*>i Source-Ad - 100 0
1:1 - -
10.20.1.4 130.100.1.2
No As-Path 227.0.0.0
u*>i Source-Join - 100 0
1:1 200 -
10.20.1.4 150.100.1.2
No As-Path 226.0.0.0

Routes : 3
=====
*A:praragon-siml#

*A:praragon-siml# show router bgp routes mvpn-ipv4 brief
=====
BGP Router ID:10.20.1.3 AS:200 Local AS:200
=====
Legend -
Status codes : u - used, s - suppressed, h - history, d - decayed, * - valid
Origin codes : i - IGP, e - EGP, ? - incomplete, > - best
=====
BGP MVPN-IPv4 Routes
=====
Flag RouteType OriginatorIP SourceIP
RD SourceAS GroupIP

u*>i Intra-Ad 10.20.1.4 -

```

```

 1:1 - -
u*>i Source-Ad - 130.100.1.2
 1:1 - 227.0.0.0
u* >i Source-Join - 150.100.1.2
 1:1 200 226.0.0.0

Routes : 3
=====
*A:praragon-siml#

*A:praragon-siml# show router bgp routes mvpn-ipv4 type source-join source-as 200 source-ip
150.100.1.2 group-ip 226.0.0.0 detail
=====
 BGP Router ID:10.20.1.3 AS:200 Local AS:200
=====
Legend -
Status codes : u - used, s - suppressed, h - history, d - decayed, * - valid
Origin codes : i - IGP, e - EGP, ? - incomplete, > - best

=====
BGP MVPN-IPv4 Routes
=====
Route Type : Source-Join
Route Dist. : 1:1
Source AS : 200
Source IP : 150.100.1.2
Group IP : 226.0.0.0
Nextthop : 10.20.1.4
From : 10.20.1.4
Res. Nextthop : 0.0.0.0
Local Pref. : 100
Aggregator AS : None
Atomic Aggr. : Not Atomic
Community : target:10.20.1.3:2
Cluster : No Cluster Members
Originator Id : None
Flags : Used Valid Best IGP
AS-Path : No As-Path
Peer Router Id : 10.20.1.4
Interface Name : NotAvailable
Aggregator : None
MED : 0

Routes : 1
=====
*A:praragon-siml#

*A:Dut-C# show router bgp routes ms-pw
=====
 BGP Router ID:10.20.1.3 AS:100 Local AS:100
=====
Legend -
Status codes : u - used, s - suppressed, h - history, d - decayed, * - valid
Origin codes : i - IGP, e - EGP, ? - incomplete, > - best, b - backup

=====
BGP MSPW Routes
=====
Flag Network RD
Nextthop AII-Type2/Preflen

```

## Show Commands

```
As-Path

? 3:10.20.1.3 100:3
 10.20.1.5 3:10.20.1.3:0/64
 200 100
? 3:10.20.1.3 100:4
 10.20.1.5 3:10.20.1.3:0/64
 200 100
u*>? 6:10.20.1.6 100:6
 10.20.1.5 6:10.20.1.6:0/64
 200 300 400

Routes : 3
=====
```

## summary

**Syntax** **summary [all]**  
**summary [family family] [neighbor ip-address]**

**Context** show>router>bgp

**Description** This command displays a summary of BGP neighbor information.

If confederations are not configured, that portion of the output will not display.

The “State” field displays the global BGP operational state. The valid values are:

Up — BGP global process is configured and running.

Down — BGP global process is administratively shutdown and not running.

Disabled — BGP global process is operationally disabled. The process must be restarted by the operator.

For example, if a BGP peer is operationally disabled, then the state in the summary table shows the state ‘Disabled’

**Parameters** **family** — Specify the type of routing information to be distributed by the BGP instance.

**Values** **ipv4** — Displays only those BGP peers that have the IPv4 family enabled.

**vpn-ipv4** — Displays the BGP peers that are IP-VPN capable.

**ipv6** — Displays the BGP peers that are IPv6 capable.

**mcast-ipv4** — Displays the BGP peers that are mcast-ipv4 capable.

**neighbor ip-address** — Clears damping information for entries received from the BGP neighbor.

**Values** ipv4-address: a.b.c.d  
ipv6-address: x:x:x:x:x:x:x (eight 16-bit pieces)  
x:x:x:x:x:d.d.d.d  
x: [0 — FFFF]H  
d: [0 — 255]D

**Output BGP Summary Output** — The following table describes the command output fields for a BGP summary.

| Label                   | Description                                                                               |
|-------------------------|-------------------------------------------------------------------------------------------|
| BGP Router ID           | The local BGP router ID.                                                                  |
| AS                      | The configured autonomous system number.                                                  |
| Local AS                | The configured local AS setting. If not configured, then the value is the same as the AS. |
| BGP Admin State         | Down — BGP is administratively disabled.<br>Up — BGP is administratively enabled.         |
| BGP Oper State          | Down — BGP is operationally disabled.<br>Up — BGP is operationally enabled.               |
| Bfd                     | Yes — BFD is enabled.<br>No — BFD is disabled.                                            |
| Confederation AS        | The configured confederation AS.                                                          |
| Member Confederations   | The configured members of the BGP confederation.                                          |
| Number of Peer Groups   | The total number of configured BGP peer groups.                                           |
| Number of Peers         | The total number of configured BGP peers.                                                 |
| Total BGP Active Routes | The total number of BGP routes used in the forwarding table.                              |
| Total BGP Routes        | The total number of BGP routes learned from BGP peers.                                    |
| Total BGP Paths         | The total number of unique sets of BGP path attributes learned from BGP peers.            |
| Total Path Memory       | Total amount of memory used to store the path attributes.                                 |
| Total Suppressed Routes | Total number of suppressed routes due to route damping.                                   |
| Total History Routes    | Total number of routes with history due to route damping.                                 |
| Total Decayed Routes    | Total number of decayed routes due to route damping.                                      |
| Total VPN Peer Groups   | The total number of configured VPN peer groups.                                           |
| Total VPN Peers         | The total number of configured VPN peers.                                                 |
| Total VPN Local Rts     | The total number of configured local VPN routes.                                          |

## Show Commands

| Label                        | Description (Continued)                                                                                                                 |
|------------------------------|-----------------------------------------------------------------------------------------------------------------------------------------|
| Total VPN Remote Rts         | The total number of configured remote VPN routes.                                                                                       |
| Total VPN Remote Active Rts. | The total number of active remote VPN routes used in the forwarding table.                                                              |
| Total VPN Supp.Rts.          | Total number of suppressed VPN routes due to route damping.                                                                             |
| Total VPN Hist. Rts.         | Total number of VPN routes with history due to route damping.                                                                           |
| Total VPN Decay Rts.         | Total number of decayed routes due to route damping.                                                                                    |
| Neighbor                     | BGP neighbor address.                                                                                                                   |
| AS<br>(Neighbor)             | BGP neighbor autonomous system number.                                                                                                  |
| PktRcvd                      | Total number of packets received from the BGP neighbor.                                                                                 |
| PktSent                      | Total number of packets sent to the BGP neighbor.                                                                                       |
| InQ                          | The number of BGP messages to be processed.                                                                                             |
| OutQ                         | The number of BGP messages to be transmitted.                                                                                           |
| Up/Down                      | The amount of time that the BGP neighbor has either been established or not established depending on its current state.                 |
| State Recv/Actv/<br>Sent     | The BGP neighbor's current state (if not established) or the number of received routes, active routes and sent routes (if established). |

### Sample Output

```
A:Dut-C# show router bgp summary neighbor 3FFE::A0A:1064
=====
BGP Router ID : 10.20.1.3 AS : 100 Local AS : 100
=====
BGP Admin State : Up BGP Oper State : Up
Number of Peer Groups : 4 Number of Peers : 5
Total BGP Paths : 8 Total Path Memory : 1212
Total BGP Active Rts. : 0 Total BGP Rts. : 0
Total Supressed Rts. : 0 Total Hist. Rts. : 0
Total Decay Rts. : 0

Total VPN Peer Groups : 0 Total VPN Peers : 0
Total VPN Local Rts. : 0
Total VPN Remote Rts. : 0 Total VPN Remote Active Rts. : 0
Total VPN Supp. Rts. : 0 Total VPN Hist. Rts. : 0
Total VPN Decay Rts. : 0

Total IPv6 Remote Rts. : 5 Total IPv6 Rem. Active Rts. : 4
=====
```

```

BGP Summary
=====
Neighbor
 AS PktRcvd InQ Up/Down State|Rcv/Act/Sent (IPv4)
 PktSent OutQ Rcv/Act/Sent (VpnIPv4)
 Rcv/Act/Sent (IPv6)
 Rcv/Act/Sent (MCastIPv4)

3FFE::A0A:1064
 103 489 0 00h40m28s IPv4 Incapable
 569 0 VPN-IPv4 Incapable
 1/1/3
 MCAST-IPv4 Incapable
=====

```

A:Dut-C#

A:Dut-C# show router bgp summary neighbor 10.20.1.4 family ipv6

```

=====
BGP Router ID : 10.20.1.3 AS : 100 Local AS : 100
=====
BGP Admin State : Up BGP Oper State : Up
Number of Peer Groups : 4 Number of Peers : 5
Total BGP Paths : 8 Total Path Memory : 1212
Total BGP Active Rts. : 0 Total BGP Rts. : 0
Total Supressed Rts. : 0 Total Hist. Rts. : 0
Total Decay Rts. : 0

Total VPN Peer Groups : 0 Total VPN Peers : 0
Total VPN Local Rts. : 0
Total VPN Remote Rts. : 0 Total VPN Remote Active Rts.: 0
Total VPN Supp. Rts. : 0 Total VPN Hist. Rts. : 0
Total VPN Decay Rts. : 0

Total IPv6 Remote Rts. : 5 Total IPv6 Rem. Active Rts. : 4
=====

```

BGP IPv6 Summary

```

=====
Neighbor
 AS PktRcvd PktSent InQ OutQ Up/Down State|Recv/Actv/Sent

10.20.1.4
 100 554 572 0 0 00h41m27s 1/0/3
=====

```

A:Dut-C#

A:SetupCLI>show>router# bgp summary

```

=====
BGP Router ID : 21.3.4.5 AS : 35012 Local AS : 100
=====
BGP Admin State : Up BGP Oper State : Up
Confederation AS : 40000
Member Confederations : 35012 65205 65206 65207 65208
Rapid Withdrawal : Disabled
Bfd Enabled : Yes

Number of Peer Groups : 1 Number of Peers : 1
Total BGP Paths : 3 Total Path Memory : 396
=====

```

## Show Commands

```
Total BGP Active Rts. : 0 Total BGP Rts. : 0
Total Supressed Rts. : 0 Total Hist. Rts. : 0
Total Decay Rts. : 0

Total VPN Peer Groups : 1 Total VPN Peers : 1
Total VPN Local Rts. : 0
Total VPN Remote Rts. : 0 Total VPN Remote Active Rts.: 0
Total VPN Supp. Rts. : 0 Total VPN Hist. Rts. : 0
Total VPN Decay Rts. : 0

Total IPv6 Remote Rts. : 0 Total IPv6 Rem. Active Rts.: 0
=====
BGP Summary
=====
Neighbor
 AS PktRcvd InQ Up/Down State|Rcv/Act/Sent (IPv4)
 PktSent OutQ Rcv/Act/Sent (VpnIPv4)
 Rcv/Act/Sent (IPv6)
 Rcv/Act/Sent (MCastIPv4)

3.3.3.3 20 0 0 01h55m56s Active
 0 0
=====
A:SetupCLI>show>router#
```

## mvpn

**Syntax** mvpn

**Context** show>router

**Description** This command displays Multicast VPN related information.

### Sample Output

```
*A:praragon-siml# show router 100 mvpn
=====
MVPN 100 configuration data
=====
i-psmi : 224.100.201.101 ssm admin status : Up
hello-interval : 30 seconds hello-multiplier : 35 * 0.1
three-way-hello : Disabled tracking support : Disabled

s-psmi range : 0.0.0.0/0 data-delay-interval: 3 seconds
join-tlv-packing : N/A

signaling : Bgp
vrf-import : N/A
vrf-export : N/A
vrf-target : N/A
=====
*A:praragon-siml#
```



---

## Clear Commands

### damping

**Syntax** **damping** *[[ip-prefix/ip-prefix-length] [neighbor ip-address]] | [group name]*

**Context** clear>router>bgp

**Description** This command clears or resets the route damping information for received routes.

**Parameters** *ip-prefix/ip-prefix-length* — Clears damping information for entries that match the IP prefix and prefix length.

**Values**

|                     |                                                                                             |
|---------------------|---------------------------------------------------------------------------------------------|
| ipv4-prefix:        | a.b.c.d (host bits must be 0)                                                               |
| ipv4-prefix-length: | 0 — 32                                                                                      |
| ipv6-prefix:        | x:x:x:x:x:x:x (eight 16-bit pieces)<br>x:x:x:x:x:d.d.d.d<br>x: [0 — FFFF]H<br>d: [0 — 255]D |
| ipv6-prefix-length: | 0 — 128                                                                                     |

**neighbor ip-address** — Clears damping information for entries received from the BGP neighbor.

**Values**

|               |                                                                                                                                                                   |
|---------------|-------------------------------------------------------------------------------------------------------------------------------------------------------------------|
| ipv4-address: | a.b.c.d                                                                                                                                                           |
| ipv6-address: | x:x:x:x:x:x:x (eight 16-bit pieces)<br>x:x:x:x:x:d.d.d.d<br>x: [0 — FFFF]H<br>d: [0 — 255]D<br>interface: 32 chars maximum, mandatory<br>for link local addresses |

**group name** — Clears damping information for entries received from any BGP neighbors in the peer group.

**Values** 32 characters maximum

### flap-statistics

**Syntax** **flap-statistics** *[[ip-prefix/mask] [neighbor ip-address]] | [group group-name] | [regex reg-exp] | [policy policy-name]*

**Context** clear>router>bgp

**Description** This command clears route flap statistics.

**Parameters** *ip-prefix/mask* — Clears route flap statistics for entries that match the specified IP prefix and mask length.

**Values**

|            |                               |
|------------|-------------------------------|
| ip-prefix: | a.b.c.d (host bits must be 0) |
| mask:      | 0 — 32                        |

## Clear Commands

**neighbor** *ip-address* — Clears route flap statistics for entries received from the specified BGP neighbor.

|               |               |                                     |
|---------------|---------------|-------------------------------------|
| <b>Values</b> | ipv4-address: | a.b.c.d                             |
|               | ipv6-address: | x:x:x:x:x:x:x (eight 16-bit pieces) |
|               |               | x:x:x:x:x:d.d.d.d                   |
|               |               | x: [0 — FFFF]H                      |
|               |               | d: [0 — 255]D                       |

**group** *group-name* — Clears route flap statistics for entries received from any BGP neighbors in the specified peer group.

**regex** *reg-exp* — Clears route flap statistics for all entries which have the regular expression and the AS path that matches the regular expression.

**policy** *policy-name* — Clears route flap statistics for entries that match the specified route policy.

## neighbor

**Syntax** **neighbor** {*ip-address* | **as** *as-number* | **external** | **all**} [**soft** | **soft-inbound**]  
**neighbor**{*ip-address* | **as** *as-number* | **external** | **all**} **statistics**  
**neighbor** *ip-address* **end-of-rib**

**Context** clear>router>bgp

**Description** This command resets the specified BGP peer or peers. This can cause existing BGP connections to be shutdown and restarted.

**Parameters** *ip-address* — Resets the BGP neighbor with the specified IP address.

|               |               |                                                                      |
|---------------|---------------|----------------------------------------------------------------------|
| <b>Values</b> | ipv4-address: | a.b.c.d                                                              |
|               | ipv6-address: | x:x:x:x:x:x:x[-interface]                                            |
|               |               | x:x:x:x:x:d.d.d.d[-interface]                                        |
|               |               | x: [0 — FFFF]H                                                       |
|               |               | d: [0 — 255]D                                                        |
|               |               | interface: 32 characters maximum, mandatory for link local addresses |

**as** *as-number* — Resets all BGP neighbors with the specified peer AS.

**Values** 1 — 65535

**external** — Resets all EBGp neighbors.

**all** — Resets all BGP neighbors.

**soft** — The specified BGP neighbor(s) re-evaluates all routes in the Local-RIB against the configured export policies.

**soft-inbound** — The specified BGP neighbor(s) re-evaluates all routes in the RIB-In against the configured import policies.

**statistics** — The BGP neighbor statistics.

**end-of-rib** — Clears the routing information base (RIB). This command applies when 7750 SR is helping the BGP neighbor through a BGP graceful restart. When the **clear router bgp neighbor** command is issued

without the end-of-rib option and the neighbor is in the process of restarting, stale routes from the neighbor will be retained until the stale-routes-time is reached or else the neighbor exits graceful restart. When the command is issued with the end-of-rib option, stale routes from the neighbor are deleted immediately and graceful restart procedures are aborted.

## protocol

**Syntax** protocol

**Context** clear>router>bgp

**Description** Resets the entire BGP protocol.

---

## Debug Commands

### events

**Syntax** **events** [**neighbor** *ip-address* | **group** *name*]  
**no events**

**Context** debug>router>bgp

**Description** This command logs all events changing the state of a BGP peer.

**Parameters** **neighbor** *ip-address* — Debugs only events affecting the specified BGP neighbor.

**Values**

|               |                                                                      |
|---------------|----------------------------------------------------------------------|
| ipv4-address: | a.b.c.d (host bits must be 0)                                        |
| ipv6-address: | x:x:x:x:x:x:x [-interface] (eight 16-bit pieces)                     |
|               | x:x:x:x:x:d.d.d.d [-interface]                                       |
|               | x [0 — FFFF]H                                                        |
|               | d [0 — 255]D                                                         |
|               | interface: 32 characters maximum, mandatory for link local addresses |

**group** *name* — Debugs only events affecting the specified peer group and associated neighbors.

### graceful-restart

**Syntax** **graceful-restart** [**neighbor** *ip-address* | **group** *name*]  
**no graceful-restart**

**Context** debug>router>bgp

**Description** This command enables debugging for BGP graceful-restart.  
 The no form of the command disables the debugging.

**Parameters** **neighbor** *ip-address* — Debugs only events affecting the specified BGP neighbor.

**Values**

|               |                                                                       |
|---------------|-----------------------------------------------------------------------|
| ipv4-address: | a.b.c.d (host bits must be 0)                                         |
| ipv6-address: | x:x:x:x:x:x:x[-interface]                                             |
|               | x:x:x:x:x:d.d.d.d[-interface]                                         |
|               | x: [0 — FFFF]H                                                        |
|               | d: [0 — 255]D                                                         |
|               | interface: 32 characters maximum, mandatory for link local addresses) |

**group** *name* — Debugs only events affecting the specified peer group and associated neighbors.

## keepalive

**Syntax** **keepalive** [*neighbor ip-addr* | **group name**]  
**no keepalive**

**Context** debug>router>bgp

**Description** This command decodes and logs all sent and received keepalive messages in the debug log.

**Parameters** **neighbor ip-address** — Debugs only events affecting the specified BGP neighbor.

**Values**

|               |                                                                                                                                                                      |
|---------------|----------------------------------------------------------------------------------------------------------------------------------------------------------------------|
| ipv4-address: | a.b.c.d (host bits must be 0)                                                                                                                                        |
| ipv6-address: | x:x:x:x:x:x:x[-interface]<br>x:x:x:x:x:d.d.d[-interface]<br>x: [0 — FFFF]H<br>d: [0 — 255]D<br>interface: 32 characters maximum, mandatory for link local addresses) |

**group name** — Debugs only events affecting the specified peer group and associated neighbors.

## notification

**Syntax** **notification** [*neighbor ip-address* | **group name**]  
**no notification**

**Context** debug>router>bgp

**Description** This command decodes and logs all sent and received notification messages in the debug log.

**Parameters** **neighbor ip-address** — Debugs only events affecting the specified BGP neighbor.

**Values**

|               |                                                                                                                                                                      |
|---------------|----------------------------------------------------------------------------------------------------------------------------------------------------------------------|
| ipv4-address: | a.b.c.d (host bits must be 0)                                                                                                                                        |
| ipv6-address: | x:x:x:x:x:x:x[-interface]<br>x:x:x:x:x:d.d.d[-interface]<br>x: [0 — FFFF]H<br>d: [0 — 255]D<br>interface: 32 characters maximum, mandatory for link local addresses) |

**group name** — Debugs only events affecting the specified peer group and associated neighbors.

## open

**Syntax** **open** [*neighbor ip-address* | **group name**]  
**no open**

**Context** debug>router>bgp

**Description** This command decodes and logs all sent and received open messages in the debug log.

## Debug Commands

**Parameters** **neighbor** *ip-address* — Debugs only events affecting the specified BGP neighbor.

**Values**

|               |                                                                                                                                                                          |
|---------------|--------------------------------------------------------------------------------------------------------------------------------------------------------------------------|
| ipv4-address: | a.b.c.d (host bits must be 0)                                                                                                                                            |
| ipv6-address: | x:x:x:x:x:x:x[-interface]<br>x:x:x:x:x:x:d.d.d.d[-interface]<br>x: [0 — FFFF]H<br>d: [0 — 255]D<br>interface: 32 characters maximum, mandatory for link local addresses) |

**group** *name* — Debugs only events affecting the specified peer group and associated neighbors.

## outbound-route-filtering

**Syntax** [no] **outbound-route-filtering**

**Context** debug>router>bgp

**Description** This command enables debugging for for all BGP outbound route filtering (ORF) packets. ORF is used to inform a neighbor of targets (using target-list) that it is willing to receive.

## packets

**Syntax** **packets** [**neighbor** *ip-address* | **group** *name*]  
**packets**

**Context** debug>router>bgp

**Description** This command decodes and logs all sent and received BGP packets in the debug log.

**Parameters** **neighbor** *ip-address* — Debugs only events affecting the specified BGP neighbor.

**Values**

|               |                                                                                                                                                                          |
|---------------|--------------------------------------------------------------------------------------------------------------------------------------------------------------------------|
| ipv4-address: | a.b.c.d (host bits must be 0)                                                                                                                                            |
| ipv6-address: | x:x:x:x:x:x:x[-interface]<br>x:x:x:x:x:x:d.d.d.d[-interface]<br>x: [0 — FFFF]H<br>d: [0 — 255]D<br>interface: 32 characters maximum, mandatory for link local addresses) |

**group** *name* — Debugs only events affecting the specified peer group and associated neighbors.

## route-refresh

**Syntax** **route-refresh** [*neighbor ip-address* | **group name**]  
**no route-refresh**

**Context** debug>router>bgp

**Description** This command enables and disables debugging for BGP route-refresh.

**Parameters** **neighbor ip-address** — Debugs only events affecting the specified BGP neighbor.

**Values**

|               |                                                                                                                                                                        |
|---------------|------------------------------------------------------------------------------------------------------------------------------------------------------------------------|
| ipv4-address: | a.b.c.d (host bits must be 0)                                                                                                                                          |
| ipv6-address: | x:x:x:x:x:x:x[-interface]<br>x:x:x:x:x:d.d.d.d[-interface]<br>x: [0 — FFFF]H<br>d: [0 — 255]D<br>interface: 32 characters maximum, mandatory for link local addresses) |

**group name** — Debugs only events affecting the specified peer group and associated neighbors.

## rtm

**Syntax** **rtm** [*neighbor ip-address* | **group name**]  
**no rtm**

**Context** debug>router>bgp

**Description** This command logs RTM changes in the debug log.

**Parameters** **neighbor ip-address** — Debugs only events affecting the specified BGP neighbor.

**Values**

|               |                                                                                                                                                                        |
|---------------|------------------------------------------------------------------------------------------------------------------------------------------------------------------------|
| ipv4-address: | a.b.c.d (host bits must be 0)                                                                                                                                          |
| ipv6-address: | x:x:x:x:x:x:x[-interface]<br>x:x:x:x:x:d.d.d.d[-interface]<br>x: [0 — FFFF]H<br>d: [0 — 255]D<br>interface: 32 characters maximum, mandatory for link local addresses) |

**group name** — Debugs only events affecting the specified peer group and associated neighbors.

## socket

**Syntax** **socket** [*neighbor ip-address* | **group name**]  
**no socket**

**Context** debug>router>bgp

**Description** This command logs all TCP socket events to the debug log.

## Debug Commands

**Parameters** **neighbor** *ip-address* — Debugs only events affecting the specified BGP neighbor.

**Values**

- ipv4-address: a.b.c.d (host bits must be 0)
- ipv6-address: x:x:x:x:x:x:x[-interface]  
x:x:x:x:x:d.d.d.d[-interface]
- x: [0 — FFFF]H
- d: [0 — 255]D
- interface: 32 characters maximum, mandatory for link local addresses)

**group** *name* — Debugs only events affecting the specified peer group and associated neighbors.

## timers

**Syntax** **timers** [**neighbor** *ip-address* | **group** *name*]  
**no timers**

**Context** debug>router>bgp

**Description** This command logs all BGP timer events to the debug log.

**Parameters** **neighbor** *ip-address* — Debugs only events affecting the specified BGP neighbor.

**Values**

- ipv4-address: a.b.c.d (host bits must be 0)
- ipv6-address: x:x:x:x:x:x:x[-interface]  
x:x:x:x:x:d.d.d.d[-interface]
- x: [0 — FFFF]H
- d: [0 — 255]D
- interface: 32 characters maximum, mandatory for link local addresses)

**group** *name* — Debugs only events affecting the specified peer group and associated neighbors.

## update

**Syntax** **update** [**neighbor** *ip-address* | **group** *name*]  
**no update**

**Context** debug>router>bgp

**Description** This command decodes and logs all sent and received update messages in the debug log.

**Parameters** **neighbor** *ip-address* — Debugs only events affecting the specified BGP neighbor.

**Values**

- ipv4-address: a.b.c.d (host bits must be 0)
- ipv6-address: x:x:x:x:x:x:x[-interface]  
x:x:x:x:x:d.d.d.d[-interface]
- x: [0 — FFFF]H
- d: [0 — 255]D



interface: 32 characters maximum, mandatory for link local addresses)

**group** *name* — Debugs only events affecting the specified peer group and associated neighbors.



# Route Policies

---

## In This Chapter

This chapter provides information about configuring route policies.

Topics in this chapter include:

- [Configuring Route Policies on page 732](#)
  - [Policy Statements on page 733](#)
    - [Default Action Behavior on page 734](#)
  - [BGP and OSPF Route Policy Support on page 742](#)
    - [BGP Route Policies on page 742](#)
    - [Re-advertised Route Policies on page 744](#)
    - [Triggered Policies on page 744](#)
  - [When to Use Route Policies on page 746](#)
- [Route Policy Configuration Process Overview on page 747](#)
- [Configuration Notes on page 748](#)

## Configuring Route Policies

Alcatel-Lucent's 7750 SR OS supports two databases for routing information. The routing database is composed of the routing information learned by the routing protocols. The forwarding database is composed of the routes actually used to forward traffic through a router. In addition, link state databases are maintained by interior gateway protocols (IGPs) such as IS-IS and OSPF.

Routing protocols calculate the best route to each destination and place these routes in a forwarding table. The routes in the forwarding table are used to forward routing protocol traffic, sending advertisements to neighbors and peers.

A routing policy can be configured that will not place routes associated with a specific origin in the routing table. Those routes will not be used to forward data packets to the intended destinations and the routes are not advertised by the routing protocol to neighbors and peers.

Routing policies control the size and content of the routing tables, the routes that are advertised, and the best route to take to reach a destination. Careful planning is essential to implement route policies that can affect the flow of routing information or packets in and traversing through the router. Before configuring and applying a route policy, develop an overall plan and strategy to accomplish your intended routing actions.

There are no default route policies. Each policy must be created explicitly and applied to a routing protocol or to the forwarding table. Policy parameters are modifiable.

## Policy Statements

Route policies contain policy statements containing ordered entries containing match conditions and actions you specify. The entries should be sequenced from the most explicit to least explicit. Packet forwarding and routing can be implemented according to your defined policies. Policy-based routing allows you to dictate where traffic can be routed, through specific paths, or whether to forward or drop the traffic. Route policies can match a given route policy entry and continue searching for other matches within either the same route policy or the next route policy.

The process can stop when the first complete match is found and executes the action defined in the entry, either to accept or reject packets that match the criteria or proceed to the next entry or the next policy. You can specify matching criteria based on source, destination, or particular properties of a route. Route policies can be constructed to support multiple stages to the evaluation and setting various route attributes. You can also provide more matching conditions by specifying criteria such as:

- Autonomous system (AS) path policy options — A combination of AS numbers and regular expression operators.
- Community list — A group sharing a common property.
- Prefix list — A named list of prefixes.
- To and From criteria — A route's source and destination.

### Default Action Behavior

The default action specifies how packets are to be processed when a policy related to the route is not explicitly configured. The following default actions are applied in the event that:

- A route policy does not specify a matching condition, all the routes being compared with the route policy are considered to be matches.
- A packet does not match any policy entries, then the next policy is evaluated. If a match does not occur then the last entry in the last policy is evaluated.
- If no default action is specified, the default behavior of the protocol controls whether the routes match or not.

If a default action is defined for one or more of the configured route policies, then the default action is handled as follows:

- The default action can be set to all available action states including accept, reject, next-entry, and next-policy.
  - If the action states accept or reject, then the policy evaluation terminates and the appropriate result is returned.
  - If a default action is defined and no matches occurred with the entries in the policy, then the default action is used.
  - If a default action is defined and one or more matches occurred with the entries of the policy, then the default action is not used.
- 

### Denied IP Prefixes

The following IP address prefixes are not allowed by the routing protocols and the Route Table Manager and are not be populated within the forwarding table:

- 0.0.0.0/8 or longer
- 127.0.0.0/8 or longer
- 224.0.0.0/4 or longer
- 240.0.0.0/4 or longer

Any other prefixes that need to be filtered can be filtered explicitly using route policies.

## Controlling Route Flapping

Route damping is a controlled acceptance of unstable routes from BGP peers so that any ripple effect caused by route flapping across BGP AS border routers is minimized. The motive is to delay the use of unstable routes (flapping routes) to forward data and advertisements until the route stabilizes.

Alcatel-Lucent's implementation of route damping is based on the following parameters:

- **Figure of Merit** — A route is assigned a Figure of Merit (FoM), which is proportional to the frequency of flaps. FoM should be able to characterize a route's behavior over a period of time.
- **Route flap** — A route flap is not limited to the withdrawn route. It also applies to any change in the AS path or the next hop of a reachable route. A change in AS path or next hop indicates that the intermediate AS or the route-advertising peer is not suppressing flapping routes at the source or during the propagation. Even if the route is accepted as a stable route, the data packets destined to the route could experience unstable routing due to the unstable AS path or next hop.
- **Suppress threshold** — The threshold is a configured value that, when exceeded, the route is suppressed and not advertised to other peers. The state is considered to be down from the perspective of the routing protocol.
- **Reuse threshold** — When FoM value falls below a configured reuse threshold and the route is still reachable, the route is advertised to other peers. The FoM value decays exponentially after a route is suppressed. This requires the BGP implementation to decay thousands of routes from a misbehaving peer.

The two events that could trigger the route flapping algorithm are:

- **Route flapping** — If a route flap is detected within a configured maximum route flap history time, the route's FoM is initialized and the route is marked as a potentially unstable route. Every time a route flaps, the FoM is increased and the route is suppressed if the FoM crosses the suppress threshold.
- **Route reuse timer trigger** — A suppressed route's FoM decays exponentially. When it crosses the reuse threshold, the route is eligible for advertisement if it is still reachable.

If the route continues to flap, the FoM, with respect to time scale, looks like a sawtooth waveform with the exponential rise and decay of FoM. To control flapping, the following parameters can be configured:

- **half-life** — The half life value is the time, expressed in minutes, required for a route to remain stable in order for one half of the FoM value to be reduced. For example, if the half life value is 6 (minutes) and the route remains stable for 6 minutes, then the new FoM

## Configuring Route Policies

value is 3. After another 6 minutes passes and the route remains stable, the new FoM value is 1.5.

- `max-suppress` — The maximum suppression time, expressed in minutes, is the maximum amount of time that a route can remain suppressed.
- `suppress` — If the FoM value exceeds the configured integer value, the route is suppressed for use or inclusion in advertisements.
- `reuse` — If the suppress value falls below the configured `reuse` value, then the route can be reused.



## Regular Expressions

The ability to perform a filter match on confederations in the AS-PATH is supported. This feature allows customers to configure match criteria for specific confederation sets and sequences within the AS path so that they can be filtered out before cluttering the service provider's routing information base (RIB).

7750 SR OS uses regular expression strings to specify match criteria for:

- An AS path string; for example, “100 200 300”
- A community string; for example, “100:200” where 100 is the AS number, and 200 is the community-value.
- Any AS path beginning with a confederation SET or SEQ containing 65001 and 65002 only: for example “< 65001 65002 >.\*”
- Any AS path containing a confederation SET or SEQ, regardless of the contents: for example, “.\* <.\*> .\*”

A regular expression is expressed in terms of terms and operators. A term for an AS path regular expression is:

1. Regular expressions should always be enclosed in quotes.
2. An elementary term; for example, an AS number “200”
3. A range term composed of two elementary terms separated by the ‘-’ character like “200-300”.
4. The ‘.’ dot wild-card character which matches any elementary term.
5. A regular expression enclosed in parenthesis “( )”.
6. A regular expression enclosed in square brackets used to specify a set of choices of elementary or range terms; for example. [100-300 400] matches any AS number between 100 and 300 or the AS number 400.

A term for a community string regular expression is a string that is evaluated character by character and is composed of:

1. An elementary term which for a community string is any single digit like “4”.
2. A range term composed of two elementary terms separated by the ‘-’ character like “2-3”.
3. A colon ‘:’ to delimit the AS number from the community value
4. The ‘.’ dot wild-card character which matches any elementary term or ‘:’.
5. A regular expression enclosed in parenthesis “( )”.

## Regular Expressions

6. A regular expression enclosed in square brackets used to specify a set of choices of elementary or range terms; for example, [1-37] matches any single digit between 1 and 3 or the digit 7.

The regular expression OPERATORS are listed in [Table 20](#).

**Table 20: Regular Expression Operators**

| Operator | Description                                                                                                    |
|----------|----------------------------------------------------------------------------------------------------------------|
|          | Matches the term on alternate sides of the pipe.                                                               |
| *        | Matches multiple occurrences of the term.                                                                      |
| ?        | Matches 0 or 1 occurrence of the term.                                                                         |
| +        | Matches 1 or more occurrence of the term.                                                                      |
| ( )      | Used to parenthesize so a regular expression is considered as one term.                                        |
| [ ]      | Used to demarcate a set of elementary or range terms.                                                          |
| -        | Used between the start and end of a range.                                                                     |
| {m, n}   | Matches least m and at most n repetitions of the term.                                                         |
| {m}      | Matches exactly m repetitions of the term.                                                                     |
| {m, }    | Matches m or more repetitions of the term.                                                                     |
| ^        | Matches the beginning of the string - only allowed for communities.                                            |
| \$       | Matches the end of the string - only allowed for communities.                                                  |
| \        | An escape character to indicate that the following character is a match criteria and not a grouping delimiter. |
| <>       | Matches any AS path numbers containing a confederation SET or SEQ.                                             |

Examples of AS path and community string regular expressions are listed in [Table 21](#).

**Table 21: AS Path and Community Regular Expression Examples**

| AS Path to Match Criteria                                                                                                                         | Regular Expression                                           | Example Matches                                                                                  |
|---------------------------------------------------------------------------------------------------------------------------------------------------|--------------------------------------------------------------|--------------------------------------------------------------------------------------------------|
| Null AS path                                                                                                                                      | <code>null<sup>a</sup></code>                                | Null AS path                                                                                     |
| AS path is 11                                                                                                                                     | <code>11</code>                                              | 11                                                                                               |
| AS path is 11 22 33                                                                                                                               | <code>11 22 33</code>                                        | 11 22 33                                                                                         |
| Zero or more occurrences of AS number 11                                                                                                          | <code>11*</code>                                             | Null AS path<br>11<br>11 11<br>11 11 11<br>11 ... 11                                             |
| Path of any length that begins with AS numbers 11, 22, 33                                                                                         | <code>11 22 33 .*</code>                                     | 11 22 33<br>11 22 33 400 500 600                                                                 |
| Path of any length that ends with AS numbers 44, 55, 66                                                                                           | <code>.* 44 55 66</code>                                     | 44 55 66<br>100 44 55 66<br>100 200 44 55 66<br>100 200 300 44 55 66<br>100 200 300 ... 44 55 66 |
| One occurrence of the AS numbers 100 and 200, followed by one or more occurrences of the number 33                                                | <code>100 200 33+</code>                                     | 100 200 33<br>100 200 33 33<br>100 200 33 33 33<br>100 200 33 33 33 ... 33                       |
| One or more occurrences of AS number 11, followed by one or more occurrences of AS number 22, followed by one or more occurrences of AS number 33 | <code>11+ 22+ 33+</code>                                     | 11 22 33<br>11 11 22 33<br>11 11 22 22 33<br>11 11 22 22 33 33<br>11 ... 11 22 ... 22 33 ...33   |
| Path whose second AS number must be 11 or 22                                                                                                      | <code>(. 11)   (. 22)<br/>.*<br/>or<br/>.(11   22) .*</code> | 100 11<br>200 22 300 400<br>...                                                                  |
| Path of length one or two whose second AS number might be 11 or 22                                                                                | <code>.(11   22)?</code>                                     | 100<br>200 11<br>300 22                                                                          |

## Regular Expressions

**Table 21: AS Path and Community Regular Expression Examples (Continued)**

| AS Path to Match Criteria                                                                             | Regular Expression      | Example Matches                                                                                                                                      |
|-------------------------------------------------------------------------------------------------------|-------------------------|------------------------------------------------------------------------------------------------------------------------------------------------------|
| Path whose first AS number is 100 and second AS number is either 11 or 22                             | 100 (11   22) .*        | 100 11<br>100 22 200 300                                                                                                                             |
| Either AS path 11, 22, or 33                                                                          | [11 22 33]              | 11<br>22<br>33                                                                                                                                       |
| Range of AS numbers to match a single AS number                                                       | 10-14<br>[10-12]*       | 10 or 11 or 12 or 13 or 14<br>Null AS path<br>10 or 11 or 12<br>10 10 or 10 11 or 10 12<br>11 10 or 11 11 or 11 12<br>12 10 or 12 11 or 12 12<br>... |
| Zero or one occurrence of AS number 11                                                                | 11? or 11{0,1}          | Null AS path<br>11                                                                                                                                   |
| One through four occurrences of AS number 11                                                          | 11{1,4}                 | 11<br>11 11<br>11 11 11<br>11 11 11 11                                                                                                               |
| One through four occurrences of AS number 11 followed by one occurrence of AS number 22               | 11{1,4} 22              | 11 22<br>11 11 22<br>11 11 11 22<br>11 11 11 11 22                                                                                                   |
| Path of any length, except nonexistent, whose second AS number can be anything, including nonexistent | . .* or . .{0,}         | 100<br>100 200<br>11 22 33 44 55                                                                                                                     |
| AS number is 100. Community value is 200.                                                             | ^100:200\$              | 100:200                                                                                                                                              |
| AS number is 11 or 22. Community value is any number.                                                 | ^((11)   (22)) : (.*)\$ | 11:100<br>22:100<br>11:200<br>...                                                                                                                    |
| AS number is 11. Community value is any number that starts with 1.                                    | ^11:(1.*)\$             | 11:1<br>11:100<br>11:1100<br>...                                                                                                                     |

**Table 21: AS Path and Community Regular Expression Examples (Continued)**

| AS Path to Match Criteria                                                                        | Regular Expression                                    | Example Matches                       |
|--------------------------------------------------------------------------------------------------|-------------------------------------------------------|---------------------------------------|
| AS number is any number. Community value is any number that ends with 1, 2, or 3.                | <code>^(.*) : (. * [1-3]) \$</code>                   | 11:1<br>100:2002<br>333:55553<br>...  |
| AS number is 11 or 22. Community value is any number that starts with 3 and ends with 4, 5 or 9. | <code>^((11)   (22)) : (3.* [459]) \$</code>          | 11:34<br>22:3335<br>11:3777779<br>... |
| AS number is 11 or 22. Community value ends in 33 or 44.                                         | <code>[^((11)   (22)) : (. * ((33)   (44))) \$</code> | 11:33<br>22:99944<br>22:555533<br>... |

a. The `null` keyword matches an empty AS path.

## BGP and OSPF Route Policy Support

OSPF and BGP requires route policy support. Figure 30 and Figure 32 display where route policies are evaluated in the protocol. Figure 30 depicts BGP which applies a route policy as an internal part of the BGP route selection process. Figure 32 depicts OSPF which applies routing policies at the edge of the protocol, to control only the routes that are announced to or accepted from the Route Table Manager (RTM).

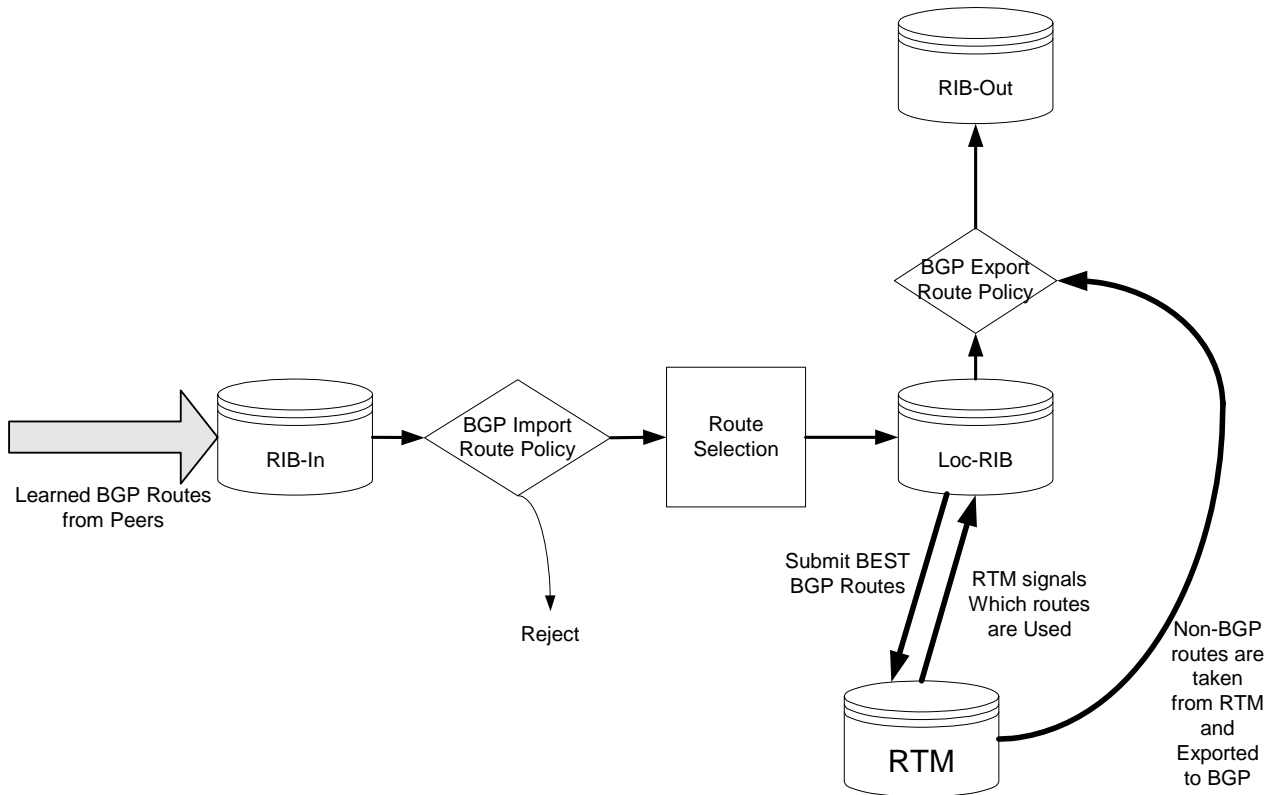

Figure 30: BGP Route Policy Diagram

### BGP Route Policies

Alcatel-Lucent’s implementation of BGP uses route policies extensively. The implied or default route policies can be overridden by customized route policies. The default BGP properties, with no route policies configured, behave as follows:

- Accept all BGP routes into the RTM for consideration.

- Announce all used BGP learned routes to other BGP peers
- Announce none of the IGP, static or local routes to BGP peers.

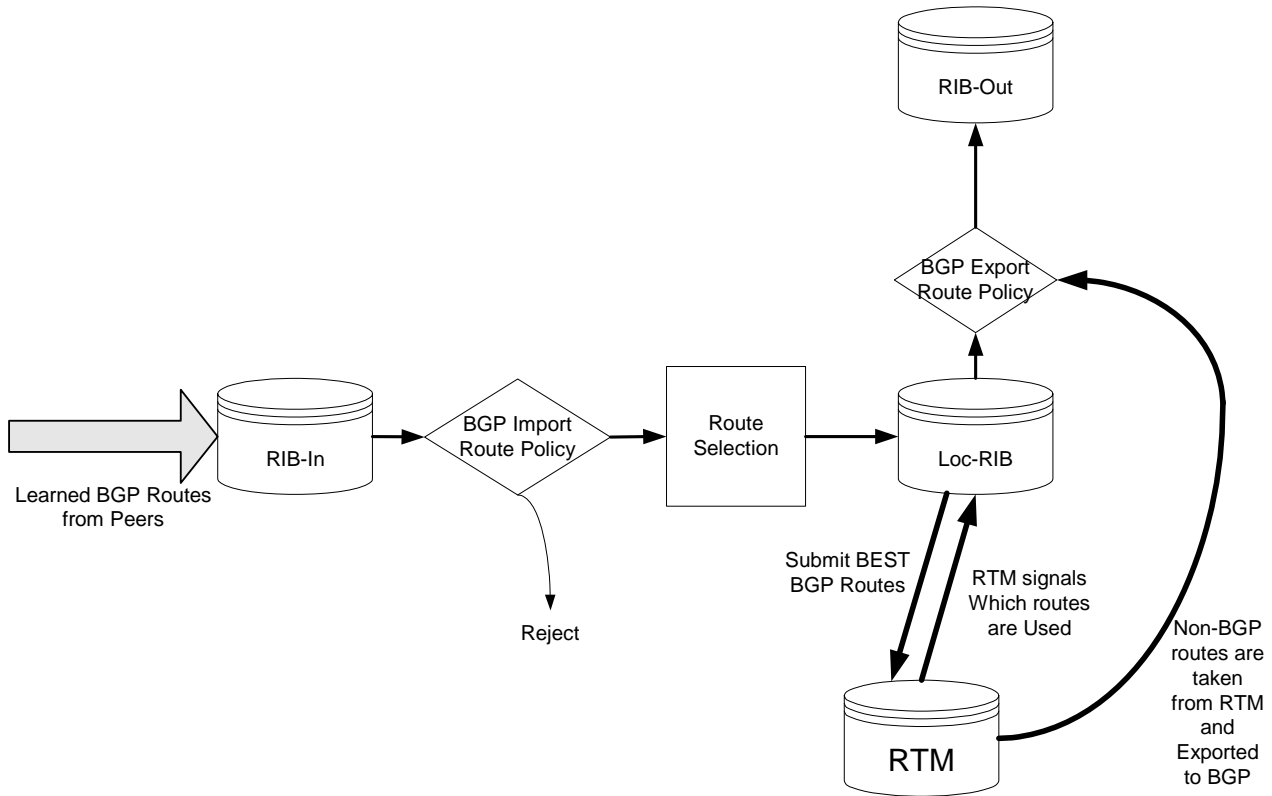

Figure 31: BGP Route Policy Diagram

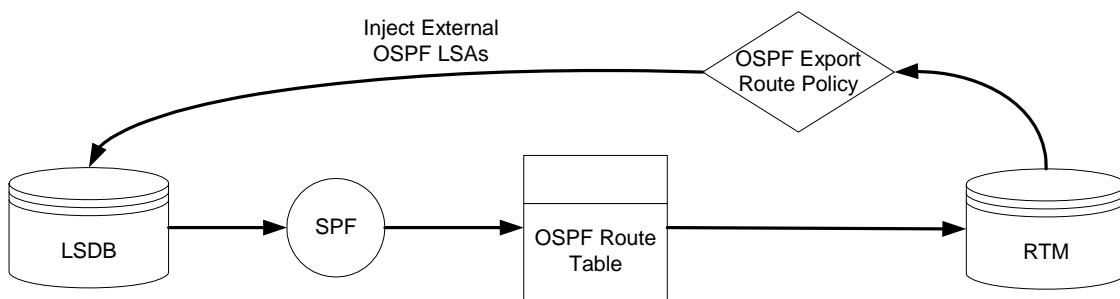

Figure 32: OSPF Route Policy Diagram

### Re-advertised Route Policies

Occasionally, BGP routes may be readvertised from BGP into OSPF, IS-IS, and RIP. OSPF export policies (policies control which routes are exported to OSPF) are not handled by the main OSPF task but are handled by a separate task or an RTM task that filters the routes before they are presented to the main OSPF task.

---

### Triggered Policies

With triggered policy enabled, deletion and re-addition of a peer after making changes to export policy causes the new updates sent out to all peers

Triggered policy is not honored if a new peer added to BGP. Update with the old policy is sent to the newly added peer. New policy does not get applied to the new peer until the peer is flapped.

With triggered policy enabled, if a new bgp/static route comes in, new addition or modification of an export policy causes the updates to sent out dynamically to all peers with the new/modified export policy

When multiple peers, say P1, P2 and P3 share the same export policy, any modifications to export policy followed by clear soft on one of the peer P1, will send out routes to P1 only according to newly modified policy.

Though routes with newly modified policy are not sent to other peers (P2, and P3) as no clear soft issues on these peers, RIB-OUT will show that new routes with modified policy are sent to all the peers. RIB-IN on peers P2 and P3 are shown correctly.

---

### Set MED to IGP Cost using Route Policies

This feature sets MED to the IGP cost of a route exported into BGP as an action in route policies. The **med-out** command in the bgp, group, and neighbor configuration context supports this option, but this method lacks per-prefix granularity. The enhanced **metric** command supported as a route policy action supports setting MED to a fixed number, or adding, or subtracting a fixed number from the received MED, and sets IGP cost option. The enhanced **metric {set {igp | number 1} | {add | subtract} number2 }** command is under **config>router>policy-options>policy-statement>entry>action**.

The **metric set igp** command, when used in a BGP export policy, have the same effect as the current **med-out igp** command, except that it applies only to the routes matched by the policy entry.



The effect of the metric set igp command depends on the route type and policy type as summarized in [Table 22](#).

**Table 22: Metric Set IGP Effect**

| <b>BGP Policy Type</b> | <b>Matched Route Type</b>                | <b>Set Metric IGP Effect</b>          |
|------------------------|------------------------------------------|---------------------------------------|
| Export                 | Non-BGP route (static, OSPF, ISIS, etc.) | Add MED attribute. Set value to M.    |
| Export                 | BGP route w/o MED                        | Add MED attribute. Set value to D.    |
| Export                 | BGP route with MED (value A)             | Overwrite MED attribute with value D. |

## When to Use Route Policies

The following are examples of circumstances of when to configure and apply unique route policies.

- When you want to control the protocol to allow all routes to be imported into the routing table. This enables the routing table to learn about particular routes to enable packet forwarding and redistributing packets into other routing protocols.
- When you want to control the exporting of a protocol's learned active routes.
- When you want a routing protocol to announce active routes learned from another routing protocol, which is sometimes called *route redistribution*.
- When you want unique behaviors to control route characteristics. For example, change the route preference.
- When you want unique behaviors to control route characteristics. For example, change the route preference, AS path, or community values to manipulate the control the route selection.
- When you want to control BGP route flapping (damping).

## Route Policy Configuration Process Overview

Figure 33 displays the process to provision basic route policy parameters.

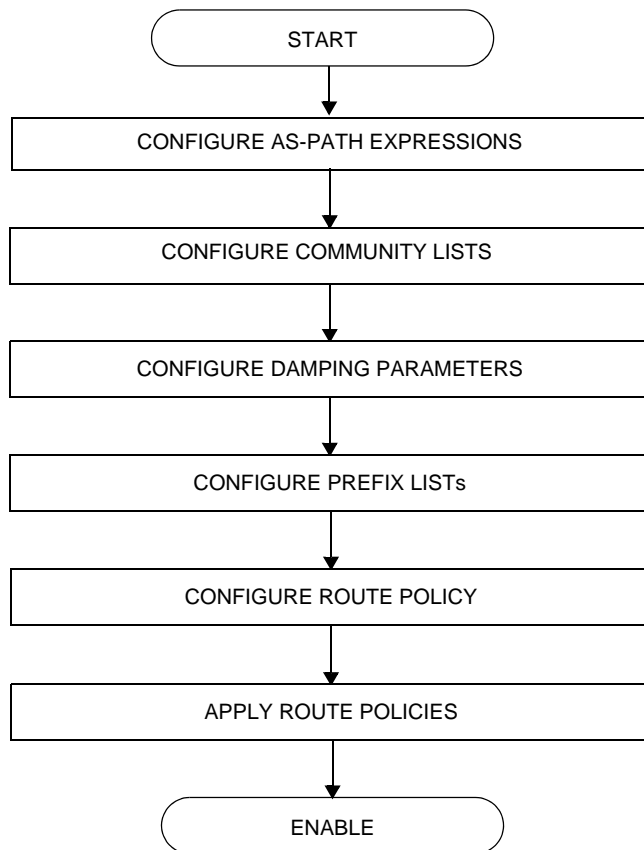

Figure 33: Route Policy Configuration and Implementation Flow

## Configuration Notes

This section describes route policy configuration caveats.

---

### General

- When configuring policy statements, the policy statement name must be unique.

## Configuring Route Policies with CLI

This section provides information to configure route policies using the command line interface.

Topics in this section include:

- [Route Policy Configuration Overview on page 750](#)
  - [When to Create Routing Policies on page 750](#)
  - [Policy Evaluation on page 752](#)
  - [Damping on page 755](#)
- [Configuring Route Policy Components on page 758](#)
  - [Creating a Route Policy on page 760](#)
  - [Beginning the Policy Statement on page 759](#)
  - [Configuring an Entry on page 762](#)
  - [Configuring a Community List on page 763](#)
  - [Configuring Damping on page 764](#)
  - [Configuring a Prefix List on page 765](#)
  - [Configuring PIM Join/Register Policies on page 766](#)
- [Route Policy Configuration Management Tasks on page 769](#)

## Route Policy Configuration Overview

Route policies allow you to configure routing according to specifically defined policies. You can create policies and entries to allow or deny paths based on various parameters such as destination address, protocol, packet size, and community list.

Policies can be as simple or complex as required. A simple policy can block routes for a specific location or IP address. More complex policies can be configured using numerous policy statement entries containing matching conditions to specify whether to accept or reject the route, control how a series of policies are evaluated, and manipulate the characteristics associated with a route.

---

### When to Create Routing Policies

Route policies are created in the **config>router** context. There are no default route policies. Each route policy must be explicitly created and applied. Applying route policies can introduce more efficiency as well as more complexity to 7750 SR-Series routers' capabilities.

A route policy impacts the flow of routing information or packets within and through the router. A routing policy can be specified to prevent a particular customer's routes to be placed in the route table which causes those routes to not forward traffic to various destinations and the routes are not advertised by the routing protocol to neighbors.

Route policies can be created to control:

- A protocol to export all the active routes learned by that protocol.
- Route characteristics to control which route is selected to act as the active route to reach a destination and advertise the route to neighbors.
- Protocol to import all routes into the routing table. A routing table must learn about particular routes to be able to forward packets and redistribute to other routing protocols.
- Damping.

Before a route policy is applied, analyze the policy's purpose and be aware of the results (and consequences) when packets match the specified criteria and the associated actions and default actions, if specified, are executed. Membership reports can be filtered based on a specific source address.

## Default Route Policy Actions

Each routing protocol has default behaviors for the import and export of routing information. [Table 23](#) shows the default behavior for each routing protocol.

**Table 23: Default Route Policy Actions**

| Protocol | Import                                                                                                          | Export                                                                                                                                                                                                                                  |
|----------|-----------------------------------------------------------------------------------------------------------------|-----------------------------------------------------------------------------------------------------------------------------------------------------------------------------------------------------------------------------------------|
| OSPF     | Not applicable. All OSPF routes are accepted from OSPF neighbors and cannot be controlled via route policies.   | <ul style="list-style-type: none"> <li>Internal routes: All OSPF routes are automatically advertised to all neighbors.</li> <li>External routes: By default all non-OSPF learned routes are not advertised to OSPF neighbors</li> </ul> |
| IS-IS    | Not applicable. All IS-IS routes are accepted from IS-IS neighbors and can not be controlled via route policies | <ul style="list-style-type: none"> <li>Internal routes: All IS-IS routes are automatically advertised to all neighbors.</li> <li>External routes: By default all non-IS-IS learned routes are not advertised to IS-IS peers.</li> </ul> |
| RIP      | By default, all RIP-learned routes are accepted.                                                                | <ul style="list-style-type: none"> <li>External routes: By default all non-RIP learned routes are not advertised to RIP peers.</li> </ul>                                                                                               |
| BGP      | By default, all routes from BGP peers are accepted and passed to the BGP route selection process.               | <ul style="list-style-type: none"> <li>Internal routes: By default all active BGP routes are advertised to BGP peers</li> <li>External routes: By default all non-BGP learned routes are not advertised to BGP peers.</li> </ul>        |

## Policy Evaluation

Routing policy statements can consist of as few as one or several entries. The entries specify the matching criteria. A route is compared to the first entry in the policy statement. If it matches, the specified entry action is taken, either accepted or rejected. If the action is to accept or reject the route, that action is taken and the evaluation of the route ends.

If the route does not match the first entry, the route is compared to the next entry (if more than one is configured) in the policy statement. If there is a match with the second entry, the specified action is taken. If the action is to accept or reject the route, that action is taken and the evaluation of the route ends, and so on.

Each route policy statement can have a default-action clause defined. If a default-action is defined for one or more of the configured route policies, then the default actions should be handled in the following ways:

- The process stops when the first complete match is found and executes the action defined in the entry.
- If the packet does not match any of the entries, the system executes the default action specified in the policy statement.

[Figure 34](#) depicts an example of the route policy process.

Route policies can also match a given route policy entry and continue to search for other entries within either the same route policy or the next route policy by specifying the *next-entry* or *next-policy* option in the entry's **action** command. Policies can be constructed to support multiple states to the evaluation and setting of various route attributes.

[Figure 35](#) depicts the next-policy and next-entry route processes.



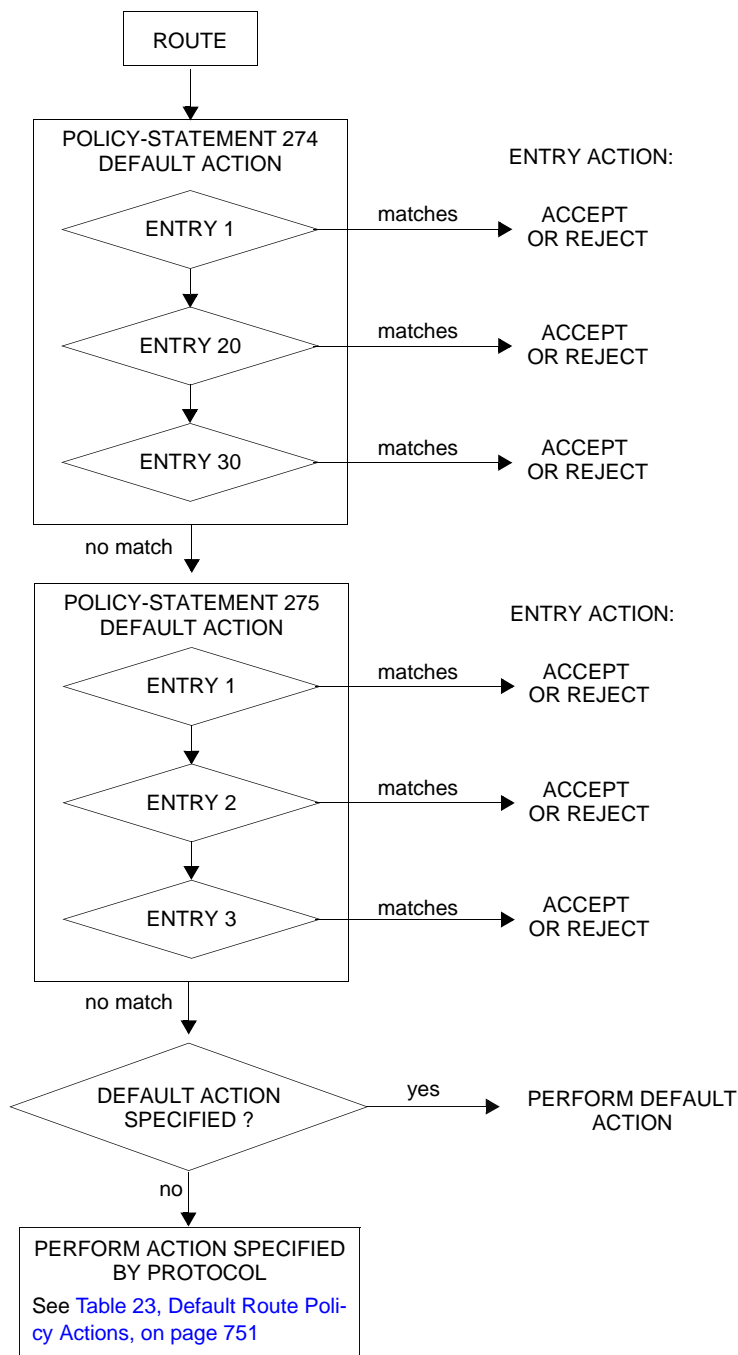

Figure 34: Route Policy Process Example

# Route Policies

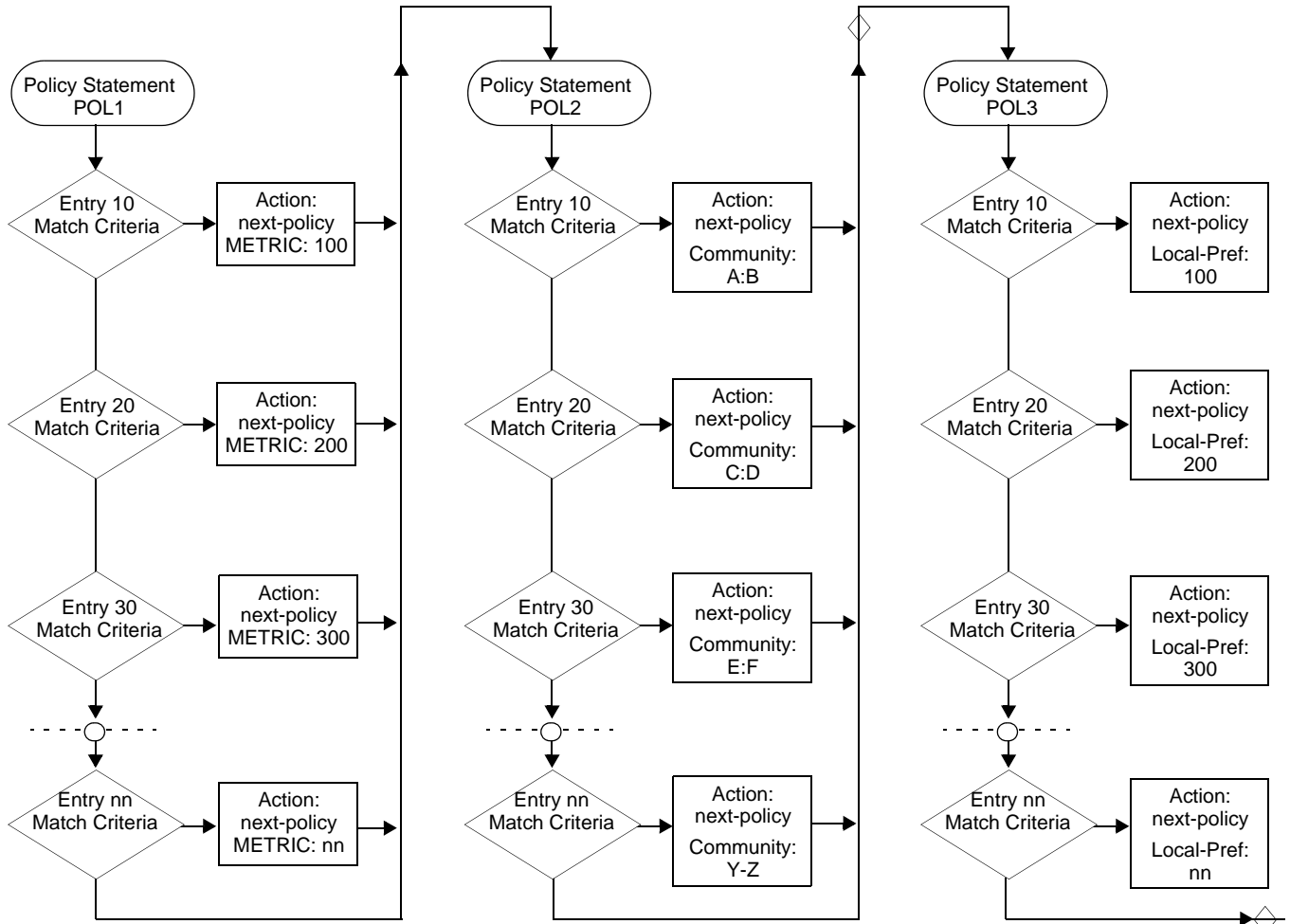

Figure 35: Next Policy Logic Example

## Damping

Damping initiates controls when routes flap. Route flapping can occur when an advertised route between nodes alternates (flaps) back and forth between two paths due to network problems which cause intermittent route failures. It is necessary to reduce the amount of routing state change updates propagated in order to limit processing requirements. Thus, when a route flaps beyond a configured value (the suppress value), then that route is removed from the routing tables and routing protocols until the value falls below the reuse value.

A route can be suppressed according to the Figure of Merit (FoM) value. The FoM is a value that is added to a route each time it flaps. A new route begins with an FoM value of 0.

Damping is optional. If damping is configured, the following parameter values must be explicitly specified as there are no default values:

- `suppress`
- `half-life`
- `reuse`
- `max-suppress`

When a route's FoM value exceeds the suppress value, then the route is removed from the routing table. The route is considered to be stable when the FoM drops below the reuse value by means of the specified half life parameter. The route is returned to the routing tables. When routes have higher FoM and half life values, they are suppressed for longer periods of time. [Figure 36](#) depicts an example of a flapping route, the suppress threshold, the half life decay (time), and reuse threshold. The peaks represent route flaps, the slopes represent half life decay.

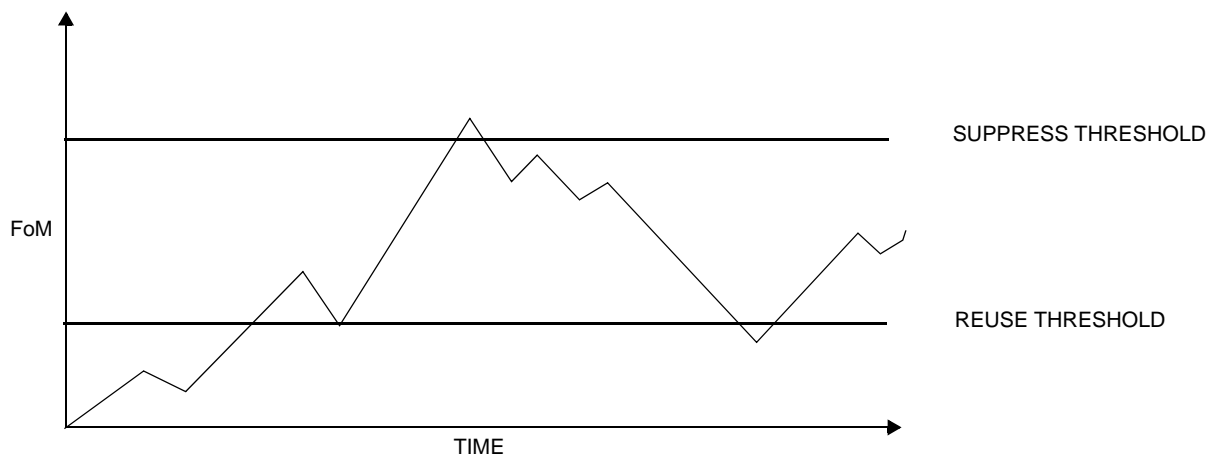

Figure 36: Damping Example

## Basic Configurations

This section provides information to configure route policies and configuration examples of common tasks. The minimal route policy parameters that need to be configured are:

- Policy statement with the following parameters specified:
  - At least one entry
  - Entry action

Following is a sample route policy configuration:

```
A:ALA-B>config>router>policy-options# info

community "all-types" members "5000:[1-6][1-9][0-9]"
community "all-normal" members "5000:[1-5][1-9][0-9]"
. . .
as-path "Outside madeup paths" ".* 5001 .*"
as-path "Outside Internet paths" ".* 5002 .*"
policy-statement "RejectOutsideASPaths"
 entry 1
 from
 protocol bgpospf
 as-path "Outside madeup paths"
 exit
 action reject
 exit
 exit
 entry 2
 from
 protocol bgpospf
 as-path "Outside Internet paths"
 exit
 action reject
 exit
 exit
 entry 3
 from
 protocol ospf
 exit
 to
 protocol bgpospf
 exit
 action reject
 exit
 exit
 entry 4
 from
 protocol isis
 exit
 to
 protocol bgpospf
 exit
 action reject
 exit
 exit
 default-action accept
 exit
exit
policy-statement "aggregate-customer-peer-only"
```

```
 entry 1
 from
 community "all-customer-announce"
 exit
 action accept
 exit
 exit
 default-action reject
 exit
 exit

A:ALA-B>config>router>policy-options#
```

## Configuring Route Policy Components

Use the CLI syntax displayed below to configure:

- [Creating a Route Policy on page 760](#)
- [Beginning the Policy Statement on page 759](#)
- [Configuring an Entry on page 762](#)
- [Configuring a Community List on page 763](#)
- [Configuring Damping on page 764](#)
- [Configuring a Prefix List on page 765](#)
- [Configuring PIM Join/Register Policies on page 766](#)

## Beginning the Policy Statement

Use the following CLI syntax to begin a policy statement configuration. In order for a policy statement to be complete an entry must be specified (see [Configuring an Entry on page 762](#)).

**CLI Syntax:** `config>router>policy-options`  
`begin`  
`policy-statement name`  
`description text`

The following error message displays when the you try to modify a policy options command without entering `begin` first.

```
A:ALA-B>config>router>policy-options# policy-statement "allow all"
MINOR: CLI The policy-options must be in edit mode by calling begin before any changes can
be made.
```

The following example displays policy statement configuration command usage. These commands are configured in the `config>router` context.

**Example:** `config>router# policy-options`  
`policy-options# begin`

There are no default policy statement options. All parameters must be explicitly configured.

## Creating a Route Policy

To enter the mode to create or edit route policies, you must enter the **begin** keyword at the **config>router>policy-options** prompt. Other editing commands include:

- The **commit** command saves changes made to route policies during a session.
- The **abort** command discards changes that have been made to route policies during a session.

The following error message displays when the you try to modify a policy options command without entering **begin** first.

```
A:ALA-B>config>router>policy-options# policy-statement "allow all"
MINOR: CLI The policy-options must be in edit mode by calling begin before any changes can
be made.
```

```
A:ALA-B>config>router>policy-options# info
#-----
Policy
#-----

policy-options
begin
policy-statement "allow all"
description "General Policy"
...
exit
exit

A:ALA-B>config>router>policy-options#
```



## Configuring a Default Action

Specifying a default action is optional. The default action controls those packets not matching any policy statement entries. If no default action is specified for the policy, then the action associated with the protocol to which the routing policy was applied is performed. The default action is applied only to those routes that do not match any policy entries.

A policy statement must include at least one entry (see [Configuring an Entry on page 762](#)).

To enter the mode to create or edit route policies, you must enter the `begin` keyword at the `config>router>policy-options` prompt. Other editing commands include:

- The **commit** command saves changes made to route policies during a session.
- The **abort** command discards changes that have been made to route policies during a session.

The following example displays the default action configuration:

```
A:ALA-B>config>router>policy-options# info

 policy-statement "1"
 default-action accept
 as-path add "test"
 community add "365"
 damping "flaptest"
 next-hop 10.10.10.104
 exit
 exit

A:ALA-B>config>router>policy-options#
```

## Configuring an Entry

An entry action must be specified. The other parameters in the **entry action** context are optional. Refer to the [Route Policy Command Reference on page 773](#) for the commands and syntax.

The following example displays entry parameters and includes the default action parameters which were displayed in the previous section.

```
A:ALA-B>config>router>policy-options# info

 policy-statement "1"
 entry 1
 to
 protocol bgp
 neighbor 10.10.10.104
 exit
 action accept
 exit
 exit
 entry 2
 from
 protocol ospf 1
 exit
 to
 protocol ospf
 neighbor 10.10.0.91
 exit
 action accept
 exit
 exit
 default-action accept
 . . .
 exit
 exit

A:ALA-B>config>router>policy-options#
 policy-statement "exporttmsgt"
 entry 1
 from
 protocol vpn-leak
 exit
 action accept
 exit
 exit
 entry 2
 from
 protocol tms
 exit
 action accept
 exit
 exit
 exit
 commit
exit
exit
```

## Configuring a Community List

Community lists are composed of a group of destinations which share a common property. Community lists allow you to administer actions on a configured group instead of having to execute identical commands for each member.

The following example displays a community list configuration:

```
A:ALA-B>config>router>policy-options# info

community "eastern" members "100:200"
community "western" members "100:300"
community "northern" members "100:400"
community "southern" members "100:500"
community "headquarters" members "100:1000"
policy-statement "1"
 entry 1
 to
 protocol bgp
 neighbor 10.10.10.104
 exit
 action accept
. . .

A:ALA-B>config>router>policy-options#
```

## Configuring Damping

NOTES:

- For each damping profile, all parameters must be configured.
- The `suppress` value must be greater than the `reuse` value (see [Figure 36 on page 755](#)).
- Damping can be enabled in the `config>router>bgp` context on the BGP global, group, and neighbor levels. If damping is enabled, but route policy does not specify a damping profile, the default damping profile will be used. This profile is always present and consists of the following parameters:

|               |            |
|---------------|------------|
| half-life:    | 15 minutes |
| max-suppress: | 60 minutes |
| suppress:     | 3000       |
| reuse:        | 750        |

The following example displays a damping configuration:

```
*A:cses-A13>config>router>policy-options# info

 damping "dampstest123"
 half-life 15
 max-suppress 60
 reuse 750
 suppress 1000
 exit

*A:cses-A13>config>router>policy-options#
```

## Configuring a Prefix List

The following example displays a prefix list configuration:

```
A:ALA-B>config>router>policy-options# info

 prefix-list "western"
 prefix 10.10.0.1/32 exact
 prefix 10.10.0.2/32 exact
 prefix 10.10.0.3/32 exact
 prefix 10.10.0.4/32 exact
 exit
 damping "dampstest123"
 half-life 15
 max-suppress 60
 reuse 750
 exit

A:ALA-B>config>router>policy-options#
```

## Configuring PIM Join/Register Policies

Join policies are used in Protocol Independent Multicast (PIM) configurations to prevent the transportation of multicast traffic across a network and the dropping of packets at a scope at the edge of the network. PIM Join filters reduce the potential for denial of service (DoS) attacks and PIM state explosion—large numbers of Joins forwarded to each router on the RPT, resulting in memory consumption. See [Importing PIM Join/Register Policies on page 81](#).

\*,G or S,G is the information used to forward unicast or multicast packets.

- **group-address** matches the group in join/prune messages  
group-address 229.55.150.208/32 exact
- **source-address** matches the source in join/prune messages  
source-address 192.168.0.0/16 longer
- **interface** matches any join message received on the specified interface  
interface port 1/1/1
- **neighbor** matches any join message received from the specified neighbor  
neighbor 1.1.1.1

The following configuration example will not allow join messages for group 229.50.50.208/32 and source 192.168.0.0/16 but allows other join messages.

### Configuring policy-statement

```
A:ALA-B>config>router# policy-options
A:ALA-B>config>router>policy-options# begin
A:ALA-B>config>router>policy-options# policy-statement foo
A:ALA-B>config>router>policy-options>policy-statement$ entry 10
A:ALA-B>config>router>policy-options>policy-statement>entry$ from
A:ALA-B>config>router>policy-options>policy-statement>entry>from$ group-address
229.50.50.208/32
A:ALA-B>config>router>policy-options>policy-statement>entry>from$ source-address
192.168.0.0
A:ALA-B>config>router>policy-options>policy-statement>entry>from$ exit
A:ALA-B>config>router>policy-options>policy-statement>entry# action reject
A:ALA-B>config>router>policy-options>policy-statement>entry#
```

The following configuration example allows registers for \*, 224.0.0.0/8.

```
A:ALA-B>config>router>policy-options# policy-statement reg-pol
A:ALA-B>config>router>policy-options>policy-statement$ entry 10
A:ALA-B>config>router>policy-options>policy-statement>entry$ from
A:ALA-B>config>router>policy-options>policy-statement>entry>from$ group-address 224.0.0.0/
8
A:ALA-B>config>router>policy-options>policy-statement>entry# action accept
A:ALA-B>config>router>policy-options>policy-statement>entry>action# exit
A:ALA-B>config>router>policy-options>policy-statement>entry# exit
A:ALA-B>config>router>policy-options>policy-statement# exit
```

```
A:ALA-B>config>router>policy-options# info

...
 policy-statement "foo"
 entry 10
 from
 group-address "229.50.50.208/32"
 source-address 192.168.0.0
 exit
 action reject
 exit
 exit
 policy-statement "reg-pol"
 entry 10
 from
 group-address "224.0.0.0/8"
 exit
 action accept
 exit
 exit
exit
...

A:ALA-B>config>router>policy-options#
```

## Configuring Bootstrap Message Import and Export Policies

Bootstrap import and export policies are used to control the flow of bootstrap messages to and from the RP.

The following configuration example specifies that no BSR messages received or sent out of interface port 1/1/1.

```
A:ALA-B>config>router>policy-options# policy-statement pim-import
:A:ALA-B>config>router>policy-options>policy-statement$ entry 10
:A:ALA-B>config>router>policy-options>policy-statement>entry$ from
:A:ALA-B>config>router>policy-options>policy-statement>entry>from$ interface port 1/1/1
:A:ALA-B>config>router>policy-options>policy-statement>entry>from$ exit
:A:ALA-B>config>router>policy-options>policy-statement>entry# action reject
:A:ALA-B>config>router>policy-options>policy-statement>entry# exit
:A:ALA-B>config>router>policy-options>policy-statement# exit

:A:ALA-B>config>router>policy-options# policy-statement pim-export
:A:ALA-B>config>router>policy-options>policy-statement$ entry 10
:A:ALA-B>config>router>policy-options>policy-statement>entry$ to
:A:ALA-B>config>router>policy-options>policy-statement>entry>to$ interface port 1/1/1
:A:ALA-B>config>router>policy-options>policy-statement>entry# action reject
:A:ALA-B>config>router>policy-options>policy-statement>entry# exit
:A:ALA-B>config>router>policy-options>policy-statement# exit

:A:ALA-B>configure router pim rp bootstrap-import pim-import
:A:ALA-B>configure router pim rp bootstrap-export pim-export
```



## Route Policy Configuration Management Tasks

This section discusses the following route policy configuration management tasks:

- [Editing Policy Statements and Parameters on page 769](#)
- [Deleting an Entry on page 771](#)
- [Deleting a Policy Statement on page 771](#)

### Editing Policy Statements and Parameters

Route policy statements can be edited to modify, add, or delete parameters. To enter the mode to edit route policies, you must enter the `begin` keyword at the `config>router> policy-options` prompt. Other editing commands include:

- The **commit** command saves changes made to route policies during a session.
- The **abort** command discards changes that have been made to route policies during a session.

The following example displays a changed configuration:

```
A:ALA-B>config>router>policy-options>policy-statement# info

description "Level 1"
entry 1
 to
 protocol bgp
 neighbor 10.10.10.104
 exit
 action accept
 exit
exit
entry 2
 from
 protocol ospf
 exit
 to
 protocol ospf
 neighbor 10.10.0.91
 exit
 action accept
 exit
exit
entry 4
 description "new entry"
 from
 protocol isis
 area 0.0.0.20
 exit
 action reject
```

## Route Policies

```
exit
default-action accept
 as-path add "test"
 community add "365"
 damping "flapper"
 next-hop 10.10.10.104
exit

```

## Deleting an Entry

Use the following CLI syntax to delete a policy statement entry:

```
CLI Syntax: config>router>policy-options
 begin
 commit
 abort
 policy-statement name
 no entry entry-id
```

The following example displays the commands required to delete a policy statement entry.

```
Example: config>router>policy-options# begin
 policy-options# policy-statement "1"
 policy-options>policy-statement# no entry 4
 policy-options>policy-statement# commit
```

---

## Deleting a Policy Statement

Use the following CLI syntax to delete a policy statement:

```
CLI Syntax: config>router>policy-options
 begin
 commit
 abort
 no policy-statement name
```

The following example displays the commands required to delete a policy statement.

```
Example: config>router>policy-options# begin
 policy-options# no policy-statement 1
 policy-options# commit
```



---

# Route Policy Command Reference

---

## Command Hierarchies

- [Route Policy Configuration Commands on page 773](#)
- [Show Commands on page 776](#)

## Route Policy Configuration Commands

```

config
 — [no] router
 — [no] triggered-policy
 — [no] policy-options
 — begin
 — commit
 — abort
 — as-path (policy options) name {regular-expression | null}
 — no as-path (policy options) name
 — community name members comm-id [comm-id ... (up to 15 max)]
 — no community name [members comm-id]
 — [no] damping name
 — half-life minutes
 — no half-life
 — max-suppress minutes
 — no max-suppress
 — reuse integer
 — no reuse
 — suppress integer
 — no suppress
 — [no] policy-statement name
 — default-action {accept | next-entry | next-policy | reject}
 — no default-action
 — as-path {add | replace} name
 — no as-path
 — as-path-prepend as-number [repeat]
 — no as-path-prepend
 — community {{add name [remove name]} | {remove name [add name]} | {replace name}}
 — no community
 — damping {name | none}
 — no damping
 — local-preference local-preference
 — no local-preference
 — metric {add | subtract | set} metric
 — no metric
 — next-hop ip-address
 — no next-hop
 — [no] next-hop-self

```

- **origin** {igp | egp | incomplete}
- **no origin**
- **preference** *preference*
- **no preference**
- **tag** *hex-string*
- **no tag**
- **type** {*type*}
- **no type**
- **description** *description-string*
- **no description**
- [no] **entry** *entry-id*
  - **action** {accept| next-entry | next-policy | reject}
  - **no action**
    - **as-path** {add | replace} *name*
    - **no as-path**
    - **as-path-prepend** *as-number* [ *repeat*]
    - **no as-path-prepend**
    - **community** {{add *name* [remove *name*]} | {remove *name* [add *name*]} | {replace *name*}}
    - **no community**
    - **damping** {*name* | none}
    - **no damping**
    - **fc** *fc* [priority {low | high}]
    - **no fc**
    - **local-preference** *local-preference*
    - **no local-preference**
    - **metric** {set {igp | *number 1*} | { add | subtract} *number2*}
    - **no metric**
    - **next-hop** *ip-address*
    - **no next-hop**
    - [no] **next-hop-self**
    - [no] **next-hop-self**
    - **origin** {igp | egp | incomplete}
    - **no origin**
    - **preference** *preference*
    - **no preference**
    - **tag** *tag*
    - **no tag**
    - **type** {*type*}
    - **no type**
- **description** *description-string*
- **no description**
- [no] **from**
  - **area** *area-id*
  - **no area**
  - **as-path** *name*
  - **no as-path**
  - **community** *name*
  - **no community**
  - [no] **external**
  - **family** [ipv4] [ipv6] [mcast-ipv4] [mcast-ipv6] [vpn-ipv4] [vpn-ipv6] [l2-vpn] [mvpn-ipv4] [mdt-safi] [flow-ipv4] [route-target]
  - **no family**

- **group-address** *prefix-list-name*
- **no group-address**
- **host-ip** *prefix-list-name*
- **no host-ip**
- **interface** *interface-name*
- **no interface**
- **level** {1 | 2}
- **no level**
- **neighbor** {*ip-address* | **prefix-list** *name*}
- **no neighbor**
- **origin** {**igp** | **egp** | **incomplete** | **any**}
- **no origin**
- **prefix-list** *name* [*name...*(up to 5 max)]
- **no prefix-list**
- **protocol** *protocol* [**all** | **instance** *instance*]
- **no protocol**
- **source-address** *ip-address*
- **no source-address**
- **tag** *tag*
- **no tag**
- **type** *type*
- **no type**
- **[no] to**
  - **level** {1 | 2}
  - **no level**
  - **neighbor** {*ip-address* | **prefix-list** *name*}
  - **no neighbor**
  - **[no] prefix-list** *name* [*name...*(up to 5 max)]
  - **protocol** *protocol*
  - **no protocol**

## Route Policy Command Reference

```
config
 — [no] router
 — [no] policy-options
 — [no] prefix-list name
 — prefix ip-prefix/prefix-length [exact | longer | through length | prefix-length-range length1-length2]
 — no prefix [ipv-prefix/prefix-length] [exact | longer | through length | prefix-length-range length1-length2]
```

## Show Commands

```
show
 — router router-name
 — policy [name | damping | prefix-list name | as-path name | community name | admin]
```



---

## Route Policy Command Reference

---

### Generic Commands

#### abort

**Syntax**    **abort**

**Context**    config>router>policy-options

This command is required to discard changes made to a route policy.

**Default**    **none**

#### begin

**Syntax**    **begin**

**Context**    config>router>policy-options

**Description** This command is required in order to enter the mode to create or edit route policies.

**Default**    **none**

#### commit

**Syntax**    **commit**

**Context**    config>router>policy-options

**Description** This command is required to save changes made to a route policy.

**Default**    **none**

## Generic Commands

### description

**Syntax** **description** *string*  
**no description**

**Context** config>router>policy-options>policy-statement  
config>router>policy-options>policy-statement>entry

**Description** This command creates a text description which is stored in the configuration file to help identify the content of the entity.

The **no** form of the command removes the string from the configuration.

**Default** none

**Parameters** *string* — The description character string. Allowed values are any string up to 80 characters long composed of printable, 7-bit ASCII characters. If the string contains special characters (#, \$, spaces, etc.), the entire string must be enclosed within double quotes.

---

## Route Policy Options

### as-path (policy options)

|                    |                                                                                                                                                                                                                                                                                                                                                                                                                                                                                                                                                                                                                                                               |
|--------------------|---------------------------------------------------------------------------------------------------------------------------------------------------------------------------------------------------------------------------------------------------------------------------------------------------------------------------------------------------------------------------------------------------------------------------------------------------------------------------------------------------------------------------------------------------------------------------------------------------------------------------------------------------------------|
| <b>Syntax</b>      | <b>as-path</b> <i>name</i> { <i>reg-exp</i>   null}<br><b>no as-path</b> <i>name</i>                                                                                                                                                                                                                                                                                                                                                                                                                                                                                                                                                                          |
| <b>Context</b>     | config>router>policy-options                                                                                                                                                                                                                                                                                                                                                                                                                                                                                                                                                                                                                                  |
| <b>Description</b> | This command creates a route policy AS path regular expression statement to use in route policy entries. The <b>no</b> form of the command deletes the AS path regular expression statement.                                                                                                                                                                                                                                                                                                                                                                                                                                                                  |
| <b>Default</b>     | No AS path regular expression statement is defined.                                                                                                                                                                                                                                                                                                                                                                                                                                                                                                                                                                                                           |
| <b>Parameters</b>  | <p><i>name</i> — The AS path regular expression name. Allowed values are any string up to 32 characters long composed of printable, 7-bit ASCII characters. If the string contains special characters (#, \$, spaces, etc.), the entire string must be enclosed within double quotes.</p> <p><i>reg-exp</i> — The AS path regular expression. Allowed values are any string up to 256 characters long composed of printable, 7-bit ASCII characters. If the string contains special characters (#, \$, spaces, etc.), the entire string must be enclosed within double quotes.</p> <p>null — The AS path expressed as an empty regular expression string.</p> |

### community

|                    |                                                                                                                                                                                                                                                                                                                                                                                                                          |
|--------------------|--------------------------------------------------------------------------------------------------------------------------------------------------------------------------------------------------------------------------------------------------------------------------------------------------------------------------------------------------------------------------------------------------------------------------|
| <b>Syntax</b>      | <b>community</b> <i>name</i> <b>members</b> <i>comm-id</i> [ <i>comm-id</i> ...up to 15 max]<br><b>no community</b> <i>name</i> [ <b>members</b> <i>comm-id</i> ]                                                                                                                                                                                                                                                        |
| <b>Context</b>     | config>router>policy-options                                                                                                                                                                                                                                                                                                                                                                                             |
| <b>Description</b> | This command creates a route policy community list to use in route policy entries. The <b>no</b> form of the command deletes the community list or the provided community ID.                                                                                                                                                                                                                                            |
| <b>Default</b>     | <b>no community</b> — No community names or members are specified.                                                                                                                                                                                                                                                                                                                                                       |
| <b>Parameters</b>  | <p><i>name</i> — The community list name. Allowed values are any string up to 32 characters long composed of printable, 7-bit ASCII characters. If the string contains special characters (#, \$, spaces, etc.), the entire string must be enclosed within double quotes.</p> <p><i>comm-id</i> — The community ID. Note that up to 15 community ID strings can be specified up to a total maximum of 72 characters.</p> |
| <b>Values</b>      | <p>72 chars max</p> <p>2byte-asnumber:comm-val   reg-ex   ext-comm   well-known-comm</p> <p>ext-comm            type: {ip-address:comm-val   reg-ex1&amp;reg-ex2   ip-address&amp;reg-ex2   2byte-asnumber:ext-comm-val  4byte-asnumber:comm-val}</p> <p>2byte-asnumber    0..65535</p>                                                                                                                                  |

## Route Policy Options

|                 |                                                    |
|-----------------|----------------------------------------------------|
| comm-val        | 0..65535                                           |
| reg-ex          | 72 chars max                                       |
| type            | target, origin                                     |
| ip-address      | a.b.c.d                                            |
| ext-comm-val    | 0..4294967295                                      |
| 4byte-asnumber  | 0..4294967295                                      |
| reg-ex1         | 63 chars max                                       |
| reg-ex2         | 63 chars max                                       |
| well-known-comm | null, no-export, no-export-subconfed, no-advertise |

A community ID can be specified in different forms:

- *as-num:comm.-value* — The *as-num* is the Autonomous System Number (ASN)

|               |             |           |
|---------------|-------------|-----------|
| <b>Values</b> | as-num:     | 1 — 65535 |
|               | comm-value: | 0 — 65535 |

- type {**target** | **origin**} *:as-num:comm.-value* — The keywords **target** or **origin** denote the community as an extended community of type route target or route origin respectively. The *as-num* and *comm.-value* allow the same values as described above for regular community values.
- *reg-ex1 reg-ex2* — A regular expression string. Allowed values are any string up to 63 characters long composed of printable, 7-bit ASCII characters. If the string contains special characters (#, \$, spaces, etc.), the entire string must be enclosed within double quotes.
- *well-known-comm* — keywords **null**, **no-export**, **no-export-subconfed**, **no-advertise**

## policy-options

**Syntax** [no] **policy-options**

**Context** config>router

**Description** This command enables the context to configure route policies. Route policies are applied to the routing protocol.

The **no** form of the command deletes the route policy configuration.

**Default** none

## triggered-policy

**Syntax** [no] **triggered-policy**

**Context** config>router

**Description** This command triggers route policy re-evaluation.

By default, when a change is made to a policy in the **config router policy options** context and then committed, the change is effective immediately. There may be circumstances when the changes should or must be delayed; for example, if a policy change is implemented that would effect every BGP peer on a SR-

Series router, the consequences could be dramatic. It is more effective to control changes on a peer by peer basis.

If the **triggered-policy** command is enabled, and a given peer is established, and you want the peer to remain up, then, in order for a change to a route policy to take effect, a **clear** command with the *soft* or *soft-inbound* option must be used. In other words, when a **triggered-policy** is enabled, any routine policy change or policy assignment change within the protocol will not take effect until the protocol is reset or a clear command is issued to re-evaluate route policies; for example, **clear router bgp neighbor x.x.x.x soft**. This keeps the peer up and the change made to a route policy is applied only to that peer, or group of peers.

**Default** Non-dynamic route policy is disabled.

---

## Route Policy Damping Commands

### damping

**Syntax** [no] damping *name*

**Context** config>router>policy-options

**Description** This command creates a context to configure a route damping profile to use in route policy entries. The **no** form of the command deletes the named route damping profile.

**Default** No damping profiles are defined.

**Parameters** *name* — The damping profile name. Allowed values are any string up to 32 characters long composed of printable, 7-bit ASCII characters. If the string contains special characters (#, \$, spaces, etc.), the entire string must be enclosed within double quotes.

### half-life

**Syntax** half-life *minutes*  
no half-life

**Context** config>router>policy-options>damping

**Description** This command configures the **half-life** parameter for the route damping profile. The half life value is the time, expressed in minutes, required for a route to remain stable in order for the Figure of Merit (FoM) value to be reduced by one half; for example, if the half life value is 6 (minutes) and the route remains stable for 6 minutes, then the new FoM value is 3 (minutes). After another 3 minutes pass and the route remains stable, the new FoM value is 1.5 (minutes).

When the FoM value falls below the **reuse** threshold, the route is once again considered valid and can be reused or included in route advertisements.

The **no** form of the command removes the half life parameter from the damping profile.

**Default** No half life value is specified. The half life value must be explicitly configured.

**Parameters** *minutes* — The half life in minutes expressed as a decimal integer.

**Values** 1 — 45

## max-suppress

**Syntax** **max-suppress** *minutes*  
**no max-suppress**

**Context** config>router>policy-options>damping

**Description** This command configures the maximum suppression parameter for the route damping profile. This value indicates the maximum time, expressed in minutes, that a route can remain suppressed. The **no** form of the command removes the maximum suppression parameter from the damping profile.

**Default** **No maximum suppression time is configured.**

**Parameters** *minutes* — The maximum suppression time, in minutes, expressed as a decimal integer.  
**Values** 1 — 720

## reuse

**Syntax** **reuse** *integer*  
**no reuse**

**Context** config>router>policy-options>damping

**Description** This command configures the reuse parameter for the route damping profile. When the Figure of Merit (FoM) value falls below the **reuse** threshold, the route is once again considered valid and can be reused or included in route advertisements. The **no** form of the command removes the reuse parameter from the damping profile.

**Default** **No reuse parameter is configured.**

**Parameters** *integer* — The reuse value expressed as a decimal integer.  
**Values** 1 — 20000

## suppress

**Syntax** **suppress** *integer*  
**no suppress**

**Context** config>router>policy-options>damping

**Description** This command configures the suppression parameter for the route policy damping profile. A route is suppressed when it has flapped frequently enough to increase the Figure of Merit (FoM) value to exceed the **suppress** threshold limit. When the **FoM** value exceeds the **suppress** threshold limit, the route is removed from the route table or inclusion in advertisements. The **no** form of the command removes the suppress parameter from the damping profile.

## Route Policy Damping Commands

**Default** No suppress parameter is configured.

**Parameters** *integer* — The suppress value expressed as a decimal integer.

**Values** 1 — 20000



---

## Route Policy Prefix Commands

### prefix-list

|                    |                                                                                                                                                                                                                                                                     |
|--------------------|---------------------------------------------------------------------------------------------------------------------------------------------------------------------------------------------------------------------------------------------------------------------|
| <b>Syntax</b>      | <b>[no] prefix-list</b> <i>name</i>                                                                                                                                                                                                                                 |
| <b>Context</b>     | config>router>policy-options                                                                                                                                                                                                                                        |
| <b>Description</b> | This command creates a context to configure a prefix list to use in route policy entries.<br>The <b>no</b> form of the command deletes the named prefix list.                                                                                                       |
| <b>Default</b>     | <b>none</b>                                                                                                                                                                                                                                                         |
| <b>Parameters</b>  | <i>name</i> — The prefix list name. Allowed values are any string up to 32 characters long composed of printable, 7-bit ASCII characters. If the string contains special characters (#, \$, spaces, etc.), the entire string must be enclosed within double quotes. |

### prefix

|                    |                                                                                                                                                                                                                                                                                                                                                                                                                                                                                                                                                                                                                                                                                                                                                                                                                                                                                                                                                                           |                                     |              |                               |  |                     |        |  |              |                                     |  |  |                   |  |  |                |  |  |               |  |                     |         |
|--------------------|---------------------------------------------------------------------------------------------------------------------------------------------------------------------------------------------------------------------------------------------------------------------------------------------------------------------------------------------------------------------------------------------------------------------------------------------------------------------------------------------------------------------------------------------------------------------------------------------------------------------------------------------------------------------------------------------------------------------------------------------------------------------------------------------------------------------------------------------------------------------------------------------------------------------------------------------------------------------------|-------------------------------------|--------------|-------------------------------|--|---------------------|--------|--|--------------|-------------------------------------|--|--|-------------------|--|--|----------------|--|--|---------------|--|---------------------|---------|
| <b>Syntax</b>      | <b>[no] prefix</b> <i>ip-prefix/prefix-length</i> { <b>[exact   longer   through</b> <i>length</i> ]   <b>[prefix-length-range</b> <i>length1-length2</i> ] }<br><b>no prefix</b> [ <i>ipv-prefix/prefix-length</i> ] <b>[exact   longer   through</b> <i>length</i>   <b>prefix-length-range</b> <i>length1-length2</i> ]                                                                                                                                                                                                                                                                                                                                                                                                                                                                                                                                                                                                                                                |                                     |              |                               |  |                     |        |  |              |                                     |  |  |                   |  |  |                |  |  |               |  |                     |         |
| <b>Context</b>     | config>router>policy-options>prefix-list                                                                                                                                                                                                                                                                                                                                                                                                                                                                                                                                                                                                                                                                                                                                                                                                                                                                                                                                  |                                     |              |                               |  |                     |        |  |              |                                     |  |  |                   |  |  |                |  |  |               |  |                     |         |
| <b>Description</b> | This command creates a prefix entry in the route policy prefix list.<br>The <b>no</b> form of the command deletes the prefix entry from the prefix list.                                                                                                                                                                                                                                                                                                                                                                                                                                                                                                                                                                                                                                                                                                                                                                                                                  |                                     |              |                               |  |                     |        |  |              |                                     |  |  |                   |  |  |                |  |  |               |  |                     |         |
| <b>Parameters</b>  | <i>ip-prefix</i> — The IP prefix for prefix list entry in dotted decimal notation.<br><table> <tr> <td><b>Values</b></td> <td>ipv4-prefix:</td> <td>a.b.c.d (host bits must be 0)</td> </tr> <tr> <td></td> <td>ipv4-prefix-length:</td> <td>0 — 32</td> </tr> <tr> <td></td> <td>ipv6-prefix:</td> <td>x:x:x:x:x:x:x (eight 16-bit pieces)</td> </tr> <tr> <td></td> <td></td> <td>x:x:x:x:x:d.d.d.d</td> </tr> <tr> <td></td> <td></td> <td>x: [0 — FFFF]H</td> </tr> <tr> <td></td> <td></td> <td>d: [0 — 255]D</td> </tr> <tr> <td></td> <td>ipv6-prefix-length:</td> <td>0 — 128</td> </tr> </table> <p><b>exact</b> — Specifies the prefix list entry only matches the route with the specified <i>ip-prefix</i> and prefix <i>mask</i> (length) values.</p> <p><b>longer</b> — Specifies the prefix list entry matches any route that matches the specified <i>ip-prefix</i> and prefix <i>mask</i> length values equal to or greater than the specified mask.</p> | <b>Values</b>                       | ipv4-prefix: | a.b.c.d (host bits must be 0) |  | ipv4-prefix-length: | 0 — 32 |  | ipv6-prefix: | x:x:x:x:x:x:x (eight 16-bit pieces) |  |  | x:x:x:x:x:d.d.d.d |  |  | x: [0 — FFFF]H |  |  | d: [0 — 255]D |  | ipv6-prefix-length: | 0 — 128 |
| <b>Values</b>      | ipv4-prefix:                                                                                                                                                                                                                                                                                                                                                                                                                                                                                                                                                                                                                                                                                                                                                                                                                                                                                                                                                              | a.b.c.d (host bits must be 0)       |              |                               |  |                     |        |  |              |                                     |  |  |                   |  |  |                |  |  |               |  |                     |         |
|                    | ipv4-prefix-length:                                                                                                                                                                                                                                                                                                                                                                                                                                                                                                                                                                                                                                                                                                                                                                                                                                                                                                                                                       | 0 — 32                              |              |                               |  |                     |        |  |              |                                     |  |  |                   |  |  |                |  |  |               |  |                     |         |
|                    | ipv6-prefix:                                                                                                                                                                                                                                                                                                                                                                                                                                                                                                                                                                                                                                                                                                                                                                                                                                                                                                                                                              | x:x:x:x:x:x:x (eight 16-bit pieces) |              |                               |  |                     |        |  |              |                                     |  |  |                   |  |  |                |  |  |               |  |                     |         |
|                    |                                                                                                                                                                                                                                                                                                                                                                                                                                                                                                                                                                                                                                                                                                                                                                                                                                                                                                                                                                           | x:x:x:x:x:d.d.d.d                   |              |                               |  |                     |        |  |              |                                     |  |  |                   |  |  |                |  |  |               |  |                     |         |
|                    |                                                                                                                                                                                                                                                                                                                                                                                                                                                                                                                                                                                                                                                                                                                                                                                                                                                                                                                                                                           | x: [0 — FFFF]H                      |              |                               |  |                     |        |  |              |                                     |  |  |                   |  |  |                |  |  |               |  |                     |         |
|                    |                                                                                                                                                                                                                                                                                                                                                                                                                                                                                                                                                                                                                                                                                                                                                                                                                                                                                                                                                                           | d: [0 — 255]D                       |              |                               |  |                     |        |  |              |                                     |  |  |                   |  |  |                |  |  |               |  |                     |         |
|                    | ipv6-prefix-length:                                                                                                                                                                                                                                                                                                                                                                                                                                                                                                                                                                                                                                                                                                                                                                                                                                                                                                                                                       | 0 — 128                             |              |                               |  |                     |        |  |              |                                     |  |  |                   |  |  |                |  |  |               |  |                     |         |

## Route Policy Prefix Commands

**through** *length* — Specifies the prefix list entry matches any route that matches the specified ip-prefix and has a prefix length between the specified *length* values inclusive.

**Values** 0 — 32

**prefix-length-range** *length1 - length2* — Specifies a route must match the most significant bits and have a prefix length with the given range. The range is inclusive of start and end values.

**Values** 0 — 32, *length2 > length1*

---

## Route Policy Entry Match Commands

### entry

**Syntax** `entry entry-id`  
`no entry`

**Context** `config>router>policy-options>policy-statement`

**Description** This command creates the context to edit route policy entries within the route policy statement. Multiple entries can be created using unique entries. The 7750 SR OS exits the filter when the first match is found and executes the action specified. For this reason, entries must be sequenced correctly from most to least explicit. An entry does not require matching criteria defined (in which case, everything matches) but must have at least define an action in order to be considered complete. Entries without an action are considered incomplete and will be rendered inactive. The **no** form of the command removes the specified entry from the route policy statement.

**Default** `none`

**Parameters** *entry-id* — The entry ID expressed as a decimal integer. An *entry-id* uniquely identifies match criteria and the corresponding action. It is recommended that multiple entries be given *entry-ids* in staggered increments. This allows users to insert a new entry in an existing policy without requiring renumbering of all the existing entries.

**Values** 1 — 4294967295

### area

**Syntax** `area area-id`  
`no area`

**Context** `config>router>policy-options>policy-statement>entry>from`

**Description** This command configures an OSPF area as a route policy match criterion. This match criterion is only used in export policies. All OSPF routes (internal and external) are matched using this criterion if the best path for the route is by the specified area. The **no** form of the command removes the OSPF area match criterion.

**Default** `none`

**Parameters** *area-id* — The OSPF area ID expressed in dotted decimal notation or as a 32-bit decimal integer.

**Values** 0.0.0.0 — 255.255.255.255 (dotted decimal), 0 — 4294967295 (decimal)

## Route Policy Entry Match Commands

### as-path

|                    |                                                                                                                                                                                                                                                                                                                                                                                                                                                                                           |
|--------------------|-------------------------------------------------------------------------------------------------------------------------------------------------------------------------------------------------------------------------------------------------------------------------------------------------------------------------------------------------------------------------------------------------------------------------------------------------------------------------------------------|
| <b>Syntax</b>      | <b>as-path</b> <i>name</i><br><b>no as-path</b>                                                                                                                                                                                                                                                                                                                                                                                                                                           |
| <b>Context</b>     | config>router>policy-options>policy-statement>entry>from                                                                                                                                                                                                                                                                                                                                                                                                                                  |
| <b>Description</b> | <p>This command configures an AS path regular expression statement as a match criterion for the route policy entry.</p> <p>If no AS path criterion is specified, any AS path is considered to match.</p> <p>AS path regular expression statements are configured at the global route policy level (<b>config&gt;router&gt;policy-options&gt;as-path</b> <i>name</i>).</p> <p>The <b>no</b> form of the command removes the AS path regular expression statement as a match criterion.</p> |
| <b>Default</b>     | <b>no as-path</b> — Matches any AS path.                                                                                                                                                                                                                                                                                                                                                                                                                                                  |
| <b>Parameters</b>  | <i>name</i> — Specifies an existing name. The AS path regular expression name. Allowed values are any string up to 32 characters long composed of printable, 7-bit ASCII characters. If the string contains special characters (#, \$, spaces, etc.), the entire string must be enclosed within double quotes.                                                                                                                                                                            |

### community

|                    |                                                                                                                                                                                                                                                                        |
|--------------------|------------------------------------------------------------------------------------------------------------------------------------------------------------------------------------------------------------------------------------------------------------------------|
| <b>Syntax</b>      | <b>community</b> <i>name</i><br><b>no community</b>                                                                                                                                                                                                                    |
| <b>Context</b>     | config>router>policy-options>policy-statement>entry>from                                                                                                                                                                                                               |
| <b>Description</b> | <p>This command configures a community list as a match criterion for the route policy entry.</p> <p>If no community list is specified, any community is considered a match.</p> <p>The <b>no</b> form of the command removes the community list match criterion.</p>   |
| <b>Default</b>     | <b>no community</b> — Matches any community.                                                                                                                                                                                                                           |
| <b>Parameters</b>  | <i>name</i> — The community list name. Allowed values are any string up to 32 characters long composed of printable, 7-bit ASCII characters. If the string contains special characters (#, \$, spaces, etc.), the entire string must be enclosed within double quotes. |
|                    | The <i>name</i> specified must already be defined.                                                                                                                                                                                                                     |

### from

|                    |                                                                                                                                                 |
|--------------------|-------------------------------------------------------------------------------------------------------------------------------------------------|
| <b>Syntax</b>      | [ <b>no</b> ] <b>from</b>                                                                                                                       |
| <b>Context</b>     | config>router>policy-options>policy-statement>entry                                                                                             |
| <b>Description</b> | This command creates the context to configure policy match criteria based on a route's source or the protocol from which the route is received. |

If no condition is specified, all route sources are considered to match.

The **no** form of the command deletes the source match criteria for the route policy statement entry.

## external

**Syntax** [no] external

**Context** config>router>policy-options>policy-statement>entry>from

**Description** This command specifies the external route matching criteria for the entry.

**Default** no external

## family

**Syntax** family [ipv4] [ipv6] [mcast-ipv4] [mcast-ipv6] [vpn-ipv4] [vpn-ipv6] [l2-vpn] [mvpn-ipv4] [mdt-safi] [flow-ipv4] [route-target]  
no family

**Context** config>router>policy-options>policy-statement>entry>from

**Description** This command specifies address families as matching conditions.

**Parameters**

- ipv4** — Specifies IPv4 routing information.
- ipv6** — Specifies IPv6 routing information.
- mcast-ipv4** — Specifies multicast IPv4 routing information.
- mcast-ipv6** — Specifies multicast IPv6 routing information.
- vpn-ipv4** — Specifies IPv4 VPN routing information.
- l2-vpn** — Exchanges Layer 2 VPN information.
- mvpn-ipv4** — Exchanges Multicast VPN related information
- mdt-safi** — Exchange Multicast VPN (MDT-SAFI) related information
- flow-ipv4** — Exchanges IPv4 flowspec routes belonging to AFI 1 and SAFI 133
- route-target** — Specifies to use route targets to be advertised to the peers if ORF is enabled for this peer group

## Route Policy Entry Match Commands

### group-address

|                    |                                                                                                                                                                                                                                                                                                                                                                                                                                         |
|--------------------|-----------------------------------------------------------------------------------------------------------------------------------------------------------------------------------------------------------------------------------------------------------------------------------------------------------------------------------------------------------------------------------------------------------------------------------------|
| <b>Syntax</b>      | <b>group-address</b> <i>prefix-list-name</i><br><b>no group-address</b>                                                                                                                                                                                                                                                                                                                                                                 |
| <b>Context</b>     | config>router>policy-options>policy-statement>entry>from                                                                                                                                                                                                                                                                                                                                                                                |
| <b>Description</b> | This command specifies the multicast group-address prefix list containing multicast group-addresses that are imbedded in the join or prune packet as a filter criterion. The prefix list must be configured prior to entering this command. Prefix lists are configured in the <b>config&gt;router&gt;policy-options&gt;prefix-list</b> context.<br><br>The <b>no</b> form of the command removes the criterion from the configuration. |
| <b>Default</b>     | <b>no group-address</b>                                                                                                                                                                                                                                                                                                                                                                                                                 |
| <b>Parameters</b>  | <i>prefix-list-name</i> — The prefix-list name. Allowed values are any string up to 32 characters long composed of printable, 7-bit ASCII characters. If the string contains special characters (#, \$, spaces, etc.), the entire string must be enclosed within double quotes.<br><br>The <i>prefix-list-name</i> is defined in the <b>config&gt;router&gt;policy-options&gt;prefix-list</b> context.                                  |

### host-ip

|                    |                                                                                                                                                                                                                                                                                                                                                                                                        |
|--------------------|--------------------------------------------------------------------------------------------------------------------------------------------------------------------------------------------------------------------------------------------------------------------------------------------------------------------------------------------------------------------------------------------------------|
| <b>Syntax</b>      | <b>host-ip</b> <i>prefix-list-name</i>                                                                                                                                                                                                                                                                                                                                                                 |
| <b>Context</b>     | config>router>policy-options>policy-statement>entry>from                                                                                                                                                                                                                                                                                                                                               |
| <b>Description</b> | This command specifies a prefix list host IP address as a match criterion for the route policy-statement entry.                                                                                                                                                                                                                                                                                        |
| <b>Default</b>     | <b>no host-ip</b>                                                                                                                                                                                                                                                                                                                                                                                      |
| <b>Parameters</b>  | <i>prefix-list-name</i> — The prefix-list name. Allowed values are any string up to 32 characters long composed of printable, 7-bit ASCII characters. If the string contains special characters (#, \$, spaces, etc.), the entire string must be enclosed within double quotes.<br><br>The <i>prefix-list-name</i> is defined in the <b>config&gt;router&gt;policy-options&gt;prefix-list</b> context. |

### interface

|                    |                                                                                                                                                                                                                       |
|--------------------|-----------------------------------------------------------------------------------------------------------------------------------------------------------------------------------------------------------------------|
| <b>Syntax</b>      | <b>interface</b> <i>interface-name</i><br><b>no interface</b>                                                                                                                                                         |
| <b>Context</b>     | config>router>policy-options>policy-statement>entry>from                                                                                                                                                              |
| <b>Description</b> | This command specifies the router interface, specified either by name or address, as a filter criterion.<br><br>The <b>no</b> form of the command removes the criterion from the configuration.                       |
| <b>Default</b>     | <b>no interface</b>                                                                                                                                                                                                   |
| <b>Parameters</b>  | <i>ip-int-name</i> — Specify the name of the interface as a match criterion for this entry. If the string contains special characters (#, \$, spaces, etc.), the entire string must be enclosed within double quotes. |

## level

|                    |                                                                                                                    |
|--------------------|--------------------------------------------------------------------------------------------------------------------|
| <b>Syntax</b>      | <b>level</b> {1   2}<br><b>no level</b>                                                                            |
| <b>Context</b>     | config>router>policy-options>policy-statement>entry>from<br>config>router>policy-options>policy-statement>entry>to |
| <b>Description</b> | This command specifies the ISIS route level as a match criterion for the entry.                                    |
| <b>Default</b>     | <b>no level</b>                                                                                                    |
| <b>Parameters</b>  | 1   2 — Matches the IS-IS route learned from level 1 or level 2.                                                   |

## neighbor

|                    |                                                                                                                                                                                                                                                                                                                                              |
|--------------------|----------------------------------------------------------------------------------------------------------------------------------------------------------------------------------------------------------------------------------------------------------------------------------------------------------------------------------------------|
| <b>Syntax</b>      | <b>neighbor</b> { <i>ip-address</i>   <b>prefix-list</b> <i>name</i> }                                                                                                                                                                                                                                                                       |
|                    | <b>no neighbor</b>                                                                                                                                                                                                                                                                                                                           |
| <b>Context</b>     | config>router>policy-options>policy-statement>entry>to<br>config>router>policy-options>policy-statement>entry>from                                                                                                                                                                                                                           |
| <b>Description</b> | This command specifies the neighbor address as found in the source address of the actual join and prune message as a filter criterion. If no neighbor is specified, any neighbor is considered a match.<br>The <b>no</b> form of the of the command removes the neighbor IP match criterion from the configuration.                          |
| <b>Default</b>     | <b>no neighbor</b> — Matches any neighbor.                                                                                                                                                                                                                                                                                                   |
| <b>Parameters</b>  | <i>ip-addr</i> — The neighbor IP address in dotted decimal notation.                                                                                                                                                                                                                                                                         |
|                    | <b>Values</b>                                                                                                                                                                                                                                                                                                                                |
|                    | ipv4-address: a.b.c.d                                                                                                                                                                                                                                                                                                                        |
|                    | ipv6-address: x:x:x:x:x:x[-interface]<br>x:x:x:x:x:d.d.d.d[-interface]<br>x: [0 — FFFF]H<br>d: [0 — 255]D<br>interface (32 chars max, mandatory for link local addresses)                                                                                                                                                                    |
|                    | <b>prefix-list</b> <i>name</i> — The prefix-list name. Allowed values are any string up to 32 characters long composed of printable, 7-bit ASCII characters. If the string contains special characters (#, \$, spaces, etc.), the entire string must be enclosed within double quotes.<br>The <i>name</i> specified must already be defined. |

## Route Policy Entry Match Commands

### origin

**Syntax** **origin** {**igp** | **egp** | **incomplete** | **any** | **aaa** | **dhcp** | **ludb**}  
**no origin**

**Context** config>router>policy-options>policy-statement>entry>from

**Description** This command will configure a match criteria for the origin attribute. Originally, the origin attribute was applicable only to BGP as a mandatory well-known BGP attribute.

The functionality of the origin attribute has expanded to subscriber-management routes (/32 IPv4 host and IPv6 PD wan-host routes). Each subscriber-management route will internally (local to the node) by default carry the origin attribute with one of the three new values (aaa, dhcp and ludb). The value of the attribute will depend on the origin of the subscriber-management route. The aaa, dhcp or ludb values will never be carried in BGP updates as part of the BGP origin attribute or be otherwise visible within the BGP process.

This introduction of the three new values for the origin attribute in the subscriber-management routes will allow customized advertisement of the subscriber-management routes via routing policy.

**Default** **no origin** — Matches any BGP origin attribute

**Parameters** **igp** — Configures matching path information originating within the local AS.

**egp** — Configures matching path information originating in another AS.

**incomplete** — Configures matching path information learned by another method.

**any** — Specifies to ignore this criteria.

**aaa** — IPv4

subscriber-management /32 host routes that are originated via Radius framed-ip-address VSA other than 255.255.255.254. The 255.255.255.254 returned by the Radius indicates that the BNG (NAS) should assign an IP address from its own pool.

IPv6

subscriber-management routes that are originated through framed-ipv6-prefix (SLAAC), delegated-ipv6-prefix (IA\_PD) or alc-ipv6-address (IA\_NA) Radius attributes. This is valid for IPoE and PPPoE type host.

**dhcp** — IPv4

subscriber-management /32 host routes that are originated via DHCP server (local or remote) and also Radius framed-ip-address=255.255.255.254 (RFC 2865).

IPv6

subscriber-management routes that are assigned via local DHCPv6 server pools whose name is obtained through Alc-Delegated-IPv6-Pool (PD pool) and Framed-IPv6-Pool (NA pool) Radius attributes. This is valid for IPoE and PPPoE type hosts.

In addition, for IPoEv6 only, the pool name can be also obtained via ipv6-delegated-prefix-pool (PD pool) and ipv6-wan-address-pool (NA pool) from LUDB.

**ludb** — IPv4



subscriber-management /32 host routes that are originated via LUDB. This should also cover Radius fallback category (Radius falls back to system-defaults or to LUDB).

IPv6

subscriber-management routes obtained from LUDB via ipv6-address (IA\_NA) or ipv6-prefix (IA\_PD). This is supported only for IPoE.

## policy-statement

**Syntax** **[no] policy-statement** *name*

**Context** config>router>policy-options

**Description** This command creates the context to configure a route policy statement.

Route policy statements control the flow of routing information to and from a specific protocol, set of protocols, or to a specific BGP neighbor.

The **policy-statement** is a logical grouping of match and action criteria. A single **policy-statement** can affect routing in one or more protocols and/or one or more protocols peers/neighbors. A single **policy-statement** can also affect both the import and export of routing information.

The **no** form of the command deletes the policy statement.

**Default** **no policy-statement** — No route policy statements are defined.

**Parameters** *name* — The route policy statement name. Allowed values are any string up to 32 characters long composed of printable, 7-bit ASCII characters. If the string contains special characters (#, \$, spaces, etc.), the entire string must be enclosed within double quotes.

## prefix-list

**Syntax** **prefix-list** *name* [*name...up to 5 max*]  
**no prefix-list**

**Context** config>router>policy-options>policy-statement>entry>from  
config>router>policy-options>policy-statement>entry>to

**Description** This command configures a prefix list as a match criterion for a route policy statement entry.

If no prefix list is specified, any network prefix is considered a match.

The prefix lists specify the network prefix (this includes the prefix and length) a specific policy entry applies.

A maximum of five prefix names can be specified.

The **no** form of the command removes the prefix list match criterion.

**Default** **no prefix-list** — Matches any network prefix.

## Route Policy Entry Match Commands

**Parameters** *name* — The prefix list name. Allowed values are any string up to 32 characters long composed of printable, 7-bit ASCII characters. If the string contains special characters (#, \$, spaces, etc.), the entire string must be enclosed within double quotes.

### protocol

**Syntax** **protocol** {*protocol*} [**all** | **instance** *instance*]  
**no protocol**

**Context** config>router>policy-options>policy-statement>entry>from

**Description** This command configures a routing protocol as a match criterion for a route policy statement entry. This command is used for both import and export policies depending how it is used.

If no protocol criterion is specified, any protocol is considered a match.

The **no** form of the command removes the protocol match criterion.

**Default** **no protocol** — Matches any protocol.

**Parameters** **protocol** — The protocol name to match on.

**Values** direct, static, bgp, isis, ospf, rip, aggregate, bgp-vpn, igmp, pim, ospf3, ldp, sub-mgmt, mld, managed, vpn-leak, tms, nat

**instance** — The OSPF or IS-IS instance.

**Values** 1 — 31

**all** — OSPF- or ISIS-only keyword.

### protocol

**Syntax** **protocol** {*protocol*} [**all** | **instance** *instance*]  
**no protocol**

**Context** config>router>policy-options>policy-statement>entry>to

**Description** This command configures a routing protocol as a match criterion for a route policy statement entry. This command is used for both import and export policies depending how it is used.

If no protocol criterion is specified, any protocol is considered a match.

The **no** form of the command removes the protocol match criterion.

**Default** **no protocol** — Matches any protocol.

**Parameters** **protocol** — The protocol name to match on.

**Values** direct, static, bgp, isis, ospf, rip, aggregate, bgp-vpn, igmp, pim, ospf3, ldp, sub-mgmt, mld, managed, vpn-leak, nat

**instance** — The OSPF or IS-IS instance.

**Values** 1 — 31

**all** — OSPF- or ISIS-only keyword.

## source-address

**Syntax** **source-address** *ip-address*  
**no source-address**

**Context** config>router>policy-options>policy-statement>entry>from

**Description** This command specifies the source address that is embedded in the join or prune packet as a filter criterion. The **no** form of the command removes the criterion from the configuration.

**Default** none

**Description** This command specifies a multicast data source address as a match criterion for this entry.

**Parameters** *ip-address* — The IP prefix for the IP match criterion in dotted decimal notation.

## state

**Syntax** **state** [srrp-master | srrp-non-master]  
**[no] state**

**Context** config>router>policy-options>policy-statement>entry>from

**Description** This command will configure a match criteria on the state attribute. The state attribute carries the state of an SRRP instance and it can be applied to:

- subscriber-interface routes
- subscriber-management routes (/32 IPv4 and IPv6 PD wan-host)
- managed-routes (applicable only to IPv4).

Based on the state attribute of the route we can manipulate the route advertisement into the network.

We can enable or disable (in case there is no SRRP running) tracking of SRRP state by routes.

This is done on a per subscriber-interface route basis, where a subscriber-interface route is tracking a single SRRP instance state (SRRP instance might be in a Fate Sharing Group).

For subscriber-management and managed-routes, tracking is enabled per group interface under which SRRP is enabled.

**Default** none

**Description** This command specifies a multicast data source address as a match criterion for this entry.

**Parameters** **srrp-master** — track routes with the state attribute carrying srrp-master state.

## Route Policy Entry Match Commands

**srrp-non-master** — track routes with the state attribute carrying srrp-master state

### tag

|                    |                                                                                                                                                                                                   |
|--------------------|---------------------------------------------------------------------------------------------------------------------------------------------------------------------------------------------------|
| <b>Syntax</b>      | <b>tag</b> <i>tag</i><br><b>no tag</b>                                                                                                                                                            |
| <b>Context</b>     | config>router>policy-options>policy-statement>entry>from                                                                                                                                          |
| <b>Description</b> | This command adds an integer tag to the static route. These tags are then matched on to control route redistribution.<br>The <b>no</b> form of the command removes the tag field match criterion. |
| <b>Default</b>     | <b>no tag</b> — Matches any external LSA tag field.                                                                                                                                               |
| <b>Parameters</b>  | <i>tag</i> — Matches a specific external LSA tag field.<br><b>Values</b> <b>no-tag</b> , 1 — 4294967295                                                                                           |

### to

|                    |                                                                                                                                                                                                                                                                                                                                                                                                                                                                                                |
|--------------------|------------------------------------------------------------------------------------------------------------------------------------------------------------------------------------------------------------------------------------------------------------------------------------------------------------------------------------------------------------------------------------------------------------------------------------------------------------------------------------------------|
| <b>Syntax</b>      | <b>[no] to</b>                                                                                                                                                                                                                                                                                                                                                                                                                                                                                 |
| <b>Context</b>     | config>router>policy-options>policy-statement>entry                                                                                                                                                                                                                                                                                                                                                                                                                                            |
| <b>Description</b> | This command creates the context to configure export policy match criteria based on a route's destination or the protocol into which the route is being advertised.<br>If no condition is specified, all route destinations are considered to match.<br>The <b>to</b> command context only applies to export policies. If it is used for an import policy, match criteria is ignored.<br>The <b>no</b> form of the command deletes export match criteria for the route policy statement entry. |

### type

|                    |                                                                                                                                                                                                                                                    |
|--------------------|----------------------------------------------------------------------------------------------------------------------------------------------------------------------------------------------------------------------------------------------------|
| <b>Syntax</b>      | <b>type</b> {1   2}<br><b>no type</b>                                                                                                                                                                                                              |
| <b>Context</b>     | config>router>policy-options>policy-statement>entry>from                                                                                                                                                                                           |
| <b>Description</b> | This command configures an OSPF type metric as a match criterion in the route policy statement entry.<br>If no type is specified, any OSPF type is considered a match.<br>The <b>no</b> form of the command removes the OSPF type match criterion. |
| <b>Parameters</b>  | <b>1</b> — Matches OSPF routes with type 1 LSAs.<br><b>2</b> — Matches OSPF routes with type 2 LSAs.                                                                                                                                               |

---

## Route Policy Action Commands

### action

|                    |                                                                                                                                                                                                                                                                                                                                                                                                                                                                                                                                                                                                               |
|--------------------|---------------------------------------------------------------------------------------------------------------------------------------------------------------------------------------------------------------------------------------------------------------------------------------------------------------------------------------------------------------------------------------------------------------------------------------------------------------------------------------------------------------------------------------------------------------------------------------------------------------|
| <b>Syntax</b>      | <b>action</b> { <b>accept</b>   <b>next-entry</b>   <b>next-policy</b>   <b>reject</b> }<br><b>no action</b>                                                                                                                                                                                                                                                                                                                                                                                                                                                                                                  |
| <b>Context</b>     | config>router>policy-options>policy-statement>entry                                                                                                                                                                                                                                                                                                                                                                                                                                                                                                                                                           |
| <b>Description</b> | This command creates the context to configure actions to take for routes matching a route policy statement entry.<br><br>This command is required and must be entered for the entry to be active.<br><br>Any route policy entry without the <b>action</b> command will be considered incomplete and will be inactive.<br><br>The <b>no</b> form of the command deletes the action context from the entry.                                                                                                                                                                                                     |
| <b>Default</b>     | <b>no action</b> — No action is defined.                                                                                                                                                                                                                                                                                                                                                                                                                                                                                                                                                                      |
| <b>Parameters</b>  | <b>accept</b> — Specifies routes matching the entry match criteria will be accepted and propagated.<br><br><b>next-entry</b> — Specifies that the actions specified would be made to the route attributes and then policy evaluation would continue with next policy entry (if any others are specified).<br><br><b>next-policy</b> — Specifies that the actions specified would be made to the route attributes and then policy evaluation would continue with next route policy (if any others are specified).<br><br><b>reject</b> — Specifies routes matching the entry match criteria would be rejected. |

### as-path

|                    |                                                                                                                                                                                                                                                                                           |
|--------------------|-------------------------------------------------------------------------------------------------------------------------------------------------------------------------------------------------------------------------------------------------------------------------------------------|
| <b>Syntax</b>      | <b>as-path</b> { <b>add</b>   <b>replace</b> } <i>name</i><br><b>no as-path</b>                                                                                                                                                                                                           |
| <b>Context</b>     | config>router>policy-options>policy-statement>default-action<br>config>router>policy-options>policy-statement>entry>action                                                                                                                                                                |
| <b>Description</b> | This command assigns a BGP AS path list to routes matching the route policy statement entry.<br><br>If no AS path list is specified, the AS path attribute is not changed.<br><br>The <b>no</b> form of the command disables the AS path list editing action from the route policy entry. |
| <b>Default</b>     | <b>no as-path</b> — The AS path attribute is not changed.                                                                                                                                                                                                                                 |
| <b>Parameters</b>  | <b>add</b> — Specifies that the AS path list is to be prepended to an existing AS list.<br><br><b>replace</b> — Specifies AS path list replaces any existing as path attribute.                                                                                                           |

## Route Policy Action Commands

*name* — The AS path list name. Allowed values are any string up to 32 characters long composed of printable, 7-bit ASCII characters. If the string contains special characters (#, \$, spaces, etc.), the entire string must be enclosed within double quotes.

The *name* specified must already be defined.

### as-path-prepend

|                    |                                                                                                                                                                                                                                                                                                                                                                                                                                                               |
|--------------------|---------------------------------------------------------------------------------------------------------------------------------------------------------------------------------------------------------------------------------------------------------------------------------------------------------------------------------------------------------------------------------------------------------------------------------------------------------------|
| <b>Syntax</b>      | <b>as-path-prepend</b> <i>as-num</i> [ <i>repeat</i> ]<br><b>no as-path-prepend</b>                                                                                                                                                                                                                                                                                                                                                                           |
| <b>Context</b>     | config>router>policy-options>policy-statement>default-action<br>config>router>policy-options>policy-statement>entry>action                                                                                                                                                                                                                                                                                                                                    |
| <b>Description</b> | <p>The command prepends a BGP AS number once or numerous times to the AS path attribute of routes matching the route policy statement entry.</p> <p>If an AS number is not configured, the AS path is not changed.</p> <p>If the optional <i>number</i> is specified, then the AS number is prepended as many times as indicated by the number.</p> <p>The <b>no</b> form of the command disables the AS path prepend action from the route policy entry.</p> |
| <b>Default</b>     | <b>no as-path-prepend</b> — no AS number prepending configured.                                                                                                                                                                                                                                                                                                                                                                                               |
| <b>Parameters</b>  | <p><i>as-num</i> — The AS number to prepend expressed as a decimal integer.</p> <p><b>Values</b> 1 — 4294967295</p> <p><i>repeat</i> — The number of times to prepend the specified AS number expressed as a decimal integer.</p> <p><b>Values</b> 1 — 50</p>                                                                                                                                                                                                 |

### community

|                    |                                                                                                                                                                                                                                                                                                                                                                                                                                                                   |
|--------------------|-------------------------------------------------------------------------------------------------------------------------------------------------------------------------------------------------------------------------------------------------------------------------------------------------------------------------------------------------------------------------------------------------------------------------------------------------------------------|
| <b>Syntax</b>      | <b>community</b> {{ <b>add</b> <i>name</i> [ <b>remove</b> <i>name</i> ]}   { <b>remove</b> <i>name</i> [ <b>add</b> <i>name</i> ]}   { <b>replace</b> <i>name</i> }}<br><b>no community</b>                                                                                                                                                                                                                                                                      |
| <b>Context</b>     | config>router>policy-options>policy-statement>default-action<br>config>router>policy-options>policy-statement>entry>action                                                                                                                                                                                                                                                                                                                                        |
| <b>Description</b> | <p>This command adds or removes a BGP community list to or from routes matching the route policy statement entry.</p> <p>If no community list is specified, the community path attribute is not changed.</p> <p>The community list changes the community path attribute according to the <b>add</b> and <b>remove</b> keywords.</p> <p>The <b>no</b> form of the command disables the action to edit the community path attribute for the route policy entry.</p> |
| <b>Default</b>     | <b>no community</b> — The community path attribute is not changed.                                                                                                                                                                                                                                                                                                                                                                                                |

- Parameters**
- add** — The specified community list is added to any existing list of communities.
  - remove** — The specified community list is removed from the existing list of communities.
  - replace** — The specified community list replaces any existing community attribute.
  - name** — The community list name. Allowed values are any string up to 32 characters long composed of printable, 7-bit ASCII characters. If the string contains special characters (#, \$, spaces, etc.), the entire string must be enclosed within double quotes.

## damping

- Syntax** **damping** {*name* | **none**}  
**no damping**
- Context** config>router>policy-options>policy-statement >default-action  
config>router>policy-options>policy-statement>entry>action
- Description** This command configures a damping profile used for routes matching the route policy statement entry. If no damping criteria is specified, the default damping profile is used. The **no** form of the command removes the damping profile associated with the route policy entry.
- Default** **no damping** — Use the default damping profile.
- Parameters** *name* — The damping profile name. Allowed values are any string up to 32 characters long composed of printable, 7-bit ASCII characters. If the string contains special characters (#, \$, spaces, etc.), the entire string must be enclosed within double quotes.
- The *name* specified must already be defined.
- none** — Disables route damping for the route policy.

## fc

- Syntax** **fc** *fc* [**priority** {**low** | **high**}]  
**no fc**
- Context** config>router>policy-options>policy-statement>entry>action\$
- Description** This command associates a forwarding-class and optionally priority with the routes matched by a route policy entry. The command takes effect when the action of the route policy entry is accept, next-entry or next-policy. It has no effect except in route policies applied as VRF import policies, BGP import policies or RIP import policies.
- The **no** form of the command removes the QoS association of the routes matched by the route policy entry.
- Default** **no fc**

## Route Policy Action Commands

|                              |                                                                                                                                                                                                                                                                                                                                                                                                                                                                                                                                                                                                                                                                                                    |
|------------------------------|----------------------------------------------------------------------------------------------------------------------------------------------------------------------------------------------------------------------------------------------------------------------------------------------------------------------------------------------------------------------------------------------------------------------------------------------------------------------------------------------------------------------------------------------------------------------------------------------------------------------------------------------------------------------------------------------------|
| <b>Parameters</b>            | <i>fc</i> — Specify the name of one of the predefined forwarding classes in the system.                                                                                                                                                                                                                                                                                                                                                                                                                                                                                                                                                                                                            |
| <b>Values</b>                | be, l2, af, l1, h2, ef, h1, nc                                                                                                                                                                                                                                                                                                                                                                                                                                                                                                                                                                                                                                                                     |
| <b>Default</b>               | none (no QoS information is associated with matched routes)                                                                                                                                                                                                                                                                                                                                                                                                                                                                                                                                                                                                                                        |
| <b>priority {low   high}</b> | — This parameter associates an enqueueing priority with routes matched by the policy entry. Specifying a priority is optional.                                                                                                                                                                                                                                                                                                                                                                                                                                                                                                                                                                     |
| <b>Values</b>                | <b>high</b> — Setting the enqueueing parameter to <b>high</b> for a packet increases the likelihood of enqueueing the packet when the ingress queue is congested. Ingress enqueueing priority only affects ingress SAP queuing. Once the packet is placed in a buffer on the ingress queue, the significance of the enqueueing priority is lost.<br><b>low</b> — Setting the enqueueing parameter to <b>low</b> for a packet decreases the likelihood of enqueueing the packet when the ingress queue is congested. Ingress enqueueing priority only affects ingress SAP queuing, once the packet is placed in a buffer on the ingress queue, the significance of the enqueueing priority is lost. |
| <b>Default</b>               | low                                                                                                                                                                                                                                                                                                                                                                                                                                                                                                                                                                                                                                                                                                |

## default-action

|                    |                                                                                                                                                                                                                                                                                                                                                                                                                                                                                                                                                                                                                                                                                                                                                                                                                                  |
|--------------------|----------------------------------------------------------------------------------------------------------------------------------------------------------------------------------------------------------------------------------------------------------------------------------------------------------------------------------------------------------------------------------------------------------------------------------------------------------------------------------------------------------------------------------------------------------------------------------------------------------------------------------------------------------------------------------------------------------------------------------------------------------------------------------------------------------------------------------|
| <b>Syntax</b>      | <b>default-action {accept   next-entry   next-policy   reject}</b><br><b>no default-action</b>                                                                                                                                                                                                                                                                                                                                                                                                                                                                                                                                                                                                                                                                                                                                   |
| <b>Context</b>     | config>router>policy-options>policy-statement                                                                                                                                                                                                                                                                                                                                                                                                                                                                                                                                                                                                                                                                                                                                                                                    |
| <b>Description</b> | <p>This command enables the context to configure actions for routes that do not match any route policy statement entries when the <b>accept</b> parameter is specified.</p> <p>The default action clause can be set to all available action states including: accept, reject, next-entry and next-policy. If the action states accept or reject then the policy evaluation terminates and the appropriate result is returned.</p> <p>If a default action is defined and no match(es) occurred with the entries in the policy then the default action clause is used.</p> <p>If a default action is defined and one or more matches occurred with the entries of the policy then the default action is not used.</p> <p>The <b>no</b> form of the command deletes the <b>default-action</b> context for the policy statement.</p> |
| <b>Default</b>     | <b>no default-action</b> — No default action is specified.                                                                                                                                                                                                                                                                                                                                                                                                                                                                                                                                                                                                                                                                                                                                                                       |
| <b>Parameters</b>  | <b>accept</b> — Specifies routes matching the entry match criteria will be accepted and propagated.<br><b>next-entry</b> — Specifies that the actions specified would be made to the route attributes and then policy evaluation would continue with next policy entry (if any others are specified).<br><b>next-policy</b> — Specifies that the actions specified would be made to the route attributes and then policy evaluation would continue with next route policy (if any others are specified).<br><b>reject</b> — Specifies routes matching the entry match criteria would be rejected.                                                                                                                                                                                                                                |



## local-preference

|                    |                                                                                                                                                                                                                                                                                           |
|--------------------|-------------------------------------------------------------------------------------------------------------------------------------------------------------------------------------------------------------------------------------------------------------------------------------------|
| <b>Syntax</b>      | <b>local-preference</b> <i>preference</i><br><b>no local-preference</b>                                                                                                                                                                                                                   |
| <b>Context</b>     | config>router>policy-options>policy-statement>default-action<br>config>router>policy-options>policy-statement>entry                                                                                                                                                                       |
| <b>Description</b> | This command assigns a BGP local preference to routes matching a route policy statement entry.<br>If no local preference is specified, the BGP configured local preference is used.<br>The <b>no</b> form of the command disables assigning a local preference in the route policy entry. |
| <b>Default</b>     | <b>No local-preference</b> — BGP default preference is assigned.                                                                                                                                                                                                                          |
| <b>Parameters</b>  | <i>preference</i> — The local preference expressed as a decimal integer.<br><b>Values</b> 0 — 4294967295                                                                                                                                                                                  |

## metric

|                    |                                                                                                                                                                                                                                                                                                                                                                                                                                                                                                                                                                                                                                                                        |
|--------------------|------------------------------------------------------------------------------------------------------------------------------------------------------------------------------------------------------------------------------------------------------------------------------------------------------------------------------------------------------------------------------------------------------------------------------------------------------------------------------------------------------------------------------------------------------------------------------------------------------------------------------------------------------------------------|
| <b>Syntax</b>      | <b>metric {set {igp   <i>number 1</i>}   {add   subtract} <i>number2</i>}</b><br><b>no metric</b>                                                                                                                                                                                                                                                                                                                                                                                                                                                                                                                                                                      |
| <b>Context</b>     | config>router>policy-options>policy-statement>default-action<br>config>router>policy-options>policy-statement>entry>action                                                                                                                                                                                                                                                                                                                                                                                                                                                                                                                                             |
| <b>Description</b> | In a BGP import or export policy, this command assigns a MED value to routes matched by the policy statement entry. The MED value may be set to a fixed value (overriding the received value), set to the routing table cost of the route used to resolve the NEXT_HOP of the BGP route (igp option), or modified by adding or subtracting a fixed value offset.<br>The <b>no</b> form of the command removes the MED attribute from the matched routes.                                                                                                                                                                                                               |
| <b>Default</b>     | <b>no metric</b> — Uses the configured metric (if defined) or do not advertise a metric.                                                                                                                                                                                                                                                                                                                                                                                                                                                                                                                                                                               |
| <b>Parameters</b>  | <b>add</b> — Specified <i>integer</i> is added to any existing metric. If the result of the addition results in a number greater than 4294967295, the value 4294967295 is used.<br><b>subtract</b> — Specified <i>integer</i> is subtracted from any existing metric. If the result of the subtraction results in a number less than 0, the value of 0 is used.<br><b>set</b> — Specified <i>integer</i> replaces any existing metric.<br><b>igp</b> — Sets the MED value to the routing table cost of the route used to resolve the NEXT_HOP of the BGP route.<br><i>number</i> — The metric modifier expressed as a decimal integer.<br><b>Values</b> 0 — 4294967295 |

## Route Policy Action Commands

### next-hop

**Syntax** **next-hop** *ip-address*  
**no next-hop**

**Context** config>router>policy-options>policy-statement>default-action  
config>router>policy-options>policy-statement>entry>action

**Description** This command assigns the specified next hop IP address to routes matching the policy statement entry. If a next-hop IP address is not specified, the next-hop attribute is not changed. The **no** form of the command disables assigning a next hop address in the route policy entry.

**Default** **no next-hop** — The next hop attribute is not changed.

**Parameters** *ip-address* — The next hop IP address in dotted decimal notation.

|               |                     |                                     |
|---------------|---------------------|-------------------------------------|
| <b>Values</b> | ipv4-prefix:        | a.b.c.d (host bits must be 0)       |
|               | ipv4-prefix-length: | 0 — 32                              |
|               | ipv6-prefix:        | x:x:x:x:x:x:x (eight 16-bit pieces) |
|               |                     | x:x:x:x:x.d.d.d                     |
|               |                     | x: [0 — FFFF]H                      |
|               |                     | d: [0 — 255]D                       |

### next-hop-self

**Syntax** [**no**] **next-hop-self**

**Context** config>router>policy-options>policy-statement *name*>default-action  
config>router>policy-options>policy-statement>entry>action

**Description** This command advertises a next hop IP address belonging to this router even if a third-party next hop is available to routes matching the policy statement entry. The **no** form of the command disables advertising the next-hop-self option for the route policy entry.

**Default** **no next-hop-self** — The next hop IP address is not changed.

### next-hop-self

**Syntax** [**no**] **next-hop-self** [**multihoming** *primary-anycast secondary-anycast*]

**Context** config>router>policy-option>policy-statement>entry>action

**Description** This command configures the group or neighbor to always set the NEXTHOP path attribute to its own physical interface when advertising to a peer. This is primarily used to avoid third-party route advertisements when connected to a multi-access network.

In addition, this command can be used to enable and configure the multi-homing reliency mechanism replacing the usual BGP nexthop with a configured anycast address.

The `no` form of the command returns the setting of the BGP next-hop attribute to the default value determined by the BGP protocol.

**Default** `no next-hop-self`

**Parameters** *primary-anycast* — Specifies the anycast address that the local node will use to replace the BGP next-hop address in route updates associated peers.

*secondary-address* — Specifies the anycast address that the local node is to track.

## origin

**Syntax** `origin {igp | egp | incomplete}`  
`no origin`

**Context** `config>router>policy-options>policy-statement name>default-action`  
`config>router>policy-options>policy-statement>entry>action`

**Description** This command sets the BGP origin assigned to routes exported into BGP.  
If the routes are exported into protocols other than BGP, this option is ignored.  
The `no` form of the command disables setting the BGP origin for the route policy entry.

**Default** `no origin`

**Parameters** `igp` — Sets the path information as originating within the local AS.

`egp` — Sets the path information as originating in another AS.

`incomplete` — Sets the path information as learned by some other means.

## preference

**Syntax** `preference preference`  
`no preference`

**Context** `config>router>policy-options>policy-statement name>default-action`  
`config>router>policy-options>policy-statement>entry>action>action`

**Description** This command assigns a route preference to routes matching the route policy statement entry.  
If no preference is specified, the default Route Table Manager (RTM) preference for the protocol is used.  
The `no` form of the command disables setting an RTM preference in the route policy entry.

**Default** `no preference` — No route preference is assigned by the policy entry. The protocol default preference is used.

**Parameters** *preference* — The route preference expressed as a decimal integer.

**Values** 1 — 255 (0 represents unset - MIB only)

## Route Policy Action Commands

### tag

**Syntax** **tag** *tag*  
**no tag**

**Context** config>router>policy-options>policy-statement>default-action  
config>router>policy-options>policy-statement>entry>action

**Description** This command assigns an OSPF tag to routes matching the entry. The tag value is used to apply a tag to a route for either an OSPF or RIP route. A hexadecimal value of 4 octets can be entered.

For OSPF, all four octets can be used.

For RIP, only the two most significant octets are used if more than two octets are configured.

The **no** form of the command removes the tag.

**Default** **no tag**

**Parameters** *tag* — Assigns an OSPF, RIP or ISIS tag to routes matching the entry.

**Values** Accepts decimal or hex formats:  
OSPF and ISIS: [0x0..0xFFFFFFFF]H  
RIP: [0x0..0xFFFF]H

### type

**Syntax** **type** {*type*}  
**no type**

**Context** config>router>policy-options>policy-statement *name*>default-action  
config>router>policy-options>policy-statement>entry>action

**Description** This command assigns an OSPF type metric to routes matching the route policy statement entry and being exported into OSPF.

The **no** form of the command disables assigning an OSPF type in the route policy entry.

**Default** **no type**

**Parameters** *type* — Specifies the OSPF type metric.

**Values** 1 — Set as OSPF routes with type 1 LSAs  
2 — Set as OSPF routes with type 2 LSAs.

## Show Commands

### policy

**Syntax** `policy [name | prefix-list name | admin]`

**Context** show>router

**Description** This command displays configured policy statement information.

**Parameters** **policy name** — Displays information similar to the info command for a specific policy-statement. If a *name* is provided, the matching policy-statement displays.  
If no *statement* name is specified, a list of all policies statements and descriptions display.

**prefix-list name** — Displays the prefix lists configured in the route policy.

**admin** — If the keyword **admin** is included, the entire policy option configuration displays, including any un-committed configuration changes. This command is similar to the **info** command.

**Output** **Route Policy Output** — The following table describes route policy output fields.

| Label       | Description                                    |
|-------------|------------------------------------------------|
| Policy      | Displays a list of route policy names.         |
| Description | Displays the description of each route policy. |
| Policies    | The total number of policies configured.       |

The following route policy commands are displayed with different command parameter options:

- [show router policy on page 805](#)
- [show router policy admin on page 806](#)
- [show router policy “BGP To RIP” on page 807](#)
- [show router policy damping on page 807](#)

### Sample Output

The **show router policy** command displays all configured route policies.

```
A:ALA-1# show router policy
=====
Route Policies
=====
Policy Description

Direct And Aggregate Policy Statement ABC

Policies :
=====
```

## Show Commands

```
A:ALA-1#
```

The **show router policy admin** command is similar to the **info** command which displays information about the route policies and parameters.

```
A:ALA-1# show router policy admin
 prefix-list "All-Routes"
 prefix 0.0.0.0/0 longer
 prefix 2.0.0.0/8 longer
 prefix 3.0.0.0/8 longer
 prefix 4.0.0.0/8 longer
 prefix 5.0.0.0/8 longer
 prefix 6.0.0.0/8 exact
 prefix 224.0.0.0/24 longer
 exit
 ...
A:ALA-1#
```

The **show router policy *name*** command displays information about a specific route policy.

show router policy "BGP To RIP"

```
description "Policy Statement For 'BGP To RIP'"
 entry 10
 description "Entry For Policy 'BGP To RIP'"
 from
 protocol bgp
 exit
 to
 protocol rip
 exit
 action accept
 metric set 1
 next-hop 10.0.18.200
 tag 0x8008135
 exit
 exit
 default-action reject
A:ALA-1#
```

---

The **show router policy damping** command displays information about the route policy damping configurations.

A:ALA-1# **show router policy damping**

```
=====
Route Damping Profiles
=====
damping "TEST-LOW"
 half-life 22
 max-suppress 720
 reuse 10000
 suppress 15000
exit
damping "TEST-HIGH"
 half-life 22
 max-suppress 720
 reuse 1000
 suppress 5000
exit
damping "TEST-MEDIUM"
 half-life 22
 max-suppress 720
 reuse 5000
 suppress 11000
exit
=====
A:ALA-1#
```

Show Commands



# Standards and Protocol Support

---

## Standards Compliance

IEEE 802.1ab-REV/D3 Station and Media Access Control Connectivity Discovery  
IEEE 802.1d Bridging  
IEEE 802.1p/Q VLAN Tagging  
IEEE 802.1s Multiple Spanning Tree  
IEEE 802.1w Rapid Spanning Tree Protocol  
IEEE 802.1x Port Based Network Access Control  
IEEE 802.1ad Provider Bridges  
IEEE 802.1ah Provider Backbone Bridges  
IEEE 802.1ag Service Layer OAM  
IEEE 802.3ah Ethernet in the First Mile  
IEEE 802.1ak Multiple MAC Registration Protocol  
IEEE 802.3 10BaseT  
IEEE 802.3ad Link Aggregation  
IEEE 802.3ae 10Gbps Ethernet  
IEEE 802.3ah Ethernet OAM  
IEEE 802.3u 100BaseTX  
IEEE 802.3x Flow Control  
IEEE 802.3z 1000BaseSX/LX  
ITU-T Y.1731 OAM functions and mechanisms for Ethernet based networks  
ITU-T G.8031 Ethernet linear protection switching  
ITU-T G.8032 Ethernet Ring Protection Switching (version 2)

## Protocol Support

### OSPF

RFC 1765 OSPF Database Overflow  
RFC 2328 OSPF Version 2  
RFC 2370 Opaque LSA Support  
RFC 2740 OSPF for IPv6 (OSPFv3)  
draft-ietf-ospf-ospfv3-update-14.txt  
RFC 3101 OSPF NSSA Option  
RFC 3137 OSPF Stub Router Advertisement

RFC 3623 Graceful OSPF Restart – GR helper  
RFC 3630 Traffic Engineering (TE) Extensions to OSPF Version 2  
RFC 4203 - Shared Risk Link Group (SRLG) sub-TLV  
RFC 5185 OSPF Multi-Area Adjacency  
RFC 3623 Graceful OSPF Restart — GR helper  
RFC 3630 Traffic Engineering (TE) Extensions to OSPF Version 2  
RFC 4203 for Shared Risk Link Group (SRLG) sub-TLV

### BGP

RFC 1397 BGP Default Route Advertisement  
RFC 1772 Application of BGP in the Internet  
RFC 1965 Confederations for BGP  
RFC 1997 BGP Communities Attribute  
RFC 2385 Protection of BGP Sessions via MD5  
RFC 2439 BGP Route Flap Dampening  
RFC 2547bis BGP/MPLS VPNs  
RFC 2918 Route Refresh Capability for BGP-4  
RFC 3107 Carrying Label Information in BGP-4  
RFC 3392 Capabilities Advertisement with BGP4  
RFC 4271 BGP-4 (previously RFC 1771)  
RFC 4360 BGP Extended Communities Attribute  
RFC 4364 BGP/MPLS IP Virtual Private Networks (VPNs) (previously RFC 2547bis BGP/MPLS VPNs)  
RFC 4456 BGP Route Reflection: Alternative to Full-mesh IBGP (previously RFC 1966 & 2796)  
RFC 4486 Subcodes for BGP Cease Notification Message  
RFC 4577 OSPF as the Provider/Customer Edge Protocol for BGP/MPLS IP Virtual Private Networks (VPNs)

RFC 4659 BGP/MPLS IP Virtual Private Network (VPN) Extension for IPv6 VPN  
RFC 4684 Constrained Route Distribution for Border Gateway Protocol/MultiProtocol Label Switching (BGP/MPLS) Internet Protocol (IP) Virtual Private Networks (VPNs)  
RFC 4724 Graceful Restart Mechanism for BGP – GR helper  
RFC 4760 Multi-protocol Extensions for BGP  
RFC 4798 Connecting IPv6 Islands over IPv4 MPLS Using IPv6 Provider Edge Routers (6PE)  
RFC 4893 BGP Support for Four-octet AS Number Space  
RFC 5004 Avoid BGP Best Path Transitions from One External to Another  
RFC 5065 Confederations for BGP (obsoletes 3065)  
RFC 5291 Outbound Route Filtering Capability for BGP-4  
RFC 5575 Dissemination of Flow Specification Rules  
RFC 5668 4-Octet AS Specific BGP Extended Community  
draft-ietf-idr-add-paths  
draft-ietf-idr-best-external

### IS-IS

RFC 1142 OSI IS-IS Intra-domain Routing Protocol (ISO 10589)  
RFC 1195 Use of OSI IS-IS for routing in TCP/IP & dual environments  
RFC 2763 Dynamic Hostname Exchange for IS-IS  
RFC 2966 Domain-wide Prefix Distribution with Two-Level IS-IS  
RFC 2973 IS-IS Mesh Groups  
RFC 3373 Three-Way Handshake for Intermediate System to Intermediate System (IS-IS) Point-to-Point Adjacencies

## Standards and Protocols

RFC 3567 Intermediate System to Intermediate System (ISIS) Cryptographic Authentication  
RFC 3719 Recommendations for Interoperable Networks using IS-IS  
RFC 3784 Intermediate System to Intermediate System (IS-IS) Extensions for Traffic Engineering (TE)  
RFC 3787 Recommendations for Interoperable IP Networks  
RFC 3847 Restart Signaling for IS-IS – GR helper  
RFC 4205 for Shared Risk Link Group (SRLG) TLV  
draft-ietf-isis-igp-p2p-over-lan-05.txt

### IPSec

RFC 2401 Security Architecture for the Internet Protocol  
RFC 2409 The Internet Key Exchange (IKE)  
RFC 3706 IKE Dead Peer Detection  
RFC 3947 Negotiation of NAT-Traversal in the IKE  
RFC 3948 UDP Encapsulation of IPsec ESP Packets  
draft-ietf-ipsec-isakmp-xauth-06.txt – Extended Authentication within ISAKMP/Oakley (XAUTH)  
draft-ietf-ipsec-isakmp-modecfg-05.txt – The ISAKMP Configuration Method

### IPv6

RFC 1981 Path MTU Discovery for IPv6  
RFC 2375 IPv6 Multicast Address Assignments  
RFC 2460 Internet Protocol, Version 6 (IPv6) Specification  
RFC 2461 Neighbor Discovery for IPv6  
RFC 2462 IPv6 Stateless Address Auto configuration  
RFC 2463 Internet Control Message Protocol (ICMPv6) for the Internet Protocol Version 6 Specification  
RFC 2464 Transmission of IPv6 Packets over Ethernet Networks  
RFC 2529 Transmission of IPv6 over IPv4 Domains without Explicit Tunnels

RFC 2545 Use of BGP-4 Multiprotocol Extension for IPv6 Inter-Domain Routing  
RFC 2710 Multicast Listener Discovery (MLD) for IPv6  
RFC 2740 OSPF for IPv6  
RFC 3306 Unicast-Prefix-based IPv6 Multicast Addresses  
RFC 3315 Dynamic Host Configuration Protocol for IPv6  
RFC 3587 IPv6 Global Unicast Address Format  
RFC3590 Source Address Selection for the Multicast Listener Discovery (MLD) Protocol  
RFC 3810 Multicast Listener Discovery Version 2 (MLDv2) for IPv6  
RFC 4007 IPv6 Scoped Address Architecture  
RFC 4193 Unique Local IPv6 Unicast Addresses  
RFC 4291 IPv6 Addressing Architecture  
RFC 4552 Authentication/Confidentiality for OSPFv3  
RFC 4659 BGP-MPLS IP Virtual Private Network (VPN) Extension for IPv6 VPN  
RFC 5072 IP Version 6 over PPP  
RFC 5095 Deprecation of Type 0 Routing Headers in IPv6  
draft-ietf-isis-ipv6-05  
draft-ietf-isis-wg-multi-topology-xx.txt

### Multicast

RFC 1112 Host Extensions for IP Multicasting (Snooping)  
RFC 2236 Internet Group Management Protocol, (Snooping)  
RFC 3376 Internet Group Management Protocol, Version 3 (Snooping)  
RFC 2362 Protocol Independent Multicast-Sparse Mode (PIMSM)  
RFC 3618 Multicast Source Discovery Protocol (MSDP)  
RFC 3446 Anycast Rendezvous Point (RP) mechanism using Protocol Independent Multicast (PIM) and Multicast Source Discovery Protocol (MSDP)  
RFC 4601 Protocol Independent Multicast - Sparse Mode (PIM-SM): Protocol Specification (Revised)

RFC 4604 Using IGMPv3 and MLDv2 for Source-Specific Multicast  
RFC 4607 Source-Specific Multicast for IP  
RFC 4608 Source-Specific Protocol Independent Multicast in 232/8  
RFC 4610 Anycast-RP Using Protocol Independent Multicast (PIM)  
RFC 5186, Internet Group Management Protocol Version 3 (IGMPv3)/ Multicast Listener Discovery Version 2 (MLDv2) and Multicast Routing Protocol Interaction  
draft-ietf-pim-sm-bsr-06.txt  
draft-rosen-vpn-mcast-15.txt Multicast in MPLS/BGP IP VPNs  
draft-ietf-mboned-msdp-mib-01.txt  
draft-ietf-l3vpn-2547bis-mcast-07: Multicast in MPLS/BGP IP VPNs  
draft-ietf-l3vpn-2547bis-mcast-bgp-05: BGP Encodings and Procedures for Multicast in MPLS/BGP IP VPNs  
RFC 3956: Embedding the Rendezvous Point (RP) Address in an IPv6 Multicast Address

### MPLS — General

RFC 2430 A Provider Architecture DiffServ & TE  
RFC 2474 Definition of the DS Field the IPv4 and IPv6 Headers (Rev)  
RFC 2597 Assured Forwarding PHB Group (rev3260)  
RFC 2598 An Expedited Forwarding PHB  
RFC 3031 MPLS Architecture  
RFC 3032 MPLS Label Stack Encoding  
RFC 3443 Time To Live (TTL) Processing in Multi-Protocol Label Switching (MPLS) Networks  
RFC 4182 Removing a Restriction on the use of MPLS Explicit NULL  
RFC 3140 Per-Hop Behavior Identification Codes  
RFC 4905, Encapsulation methods for transport of layer 2 frames over MPLS  
RFC 5332 MPLS Multicast Encapsulations

### MPLS — LDP

RFC 3037 LDP Applicability

RFC 3478 Graceful Restart Mechanism for LDP – GR helper  
 RFC 5036 LDP Specification  
 RFC 5283 LDP extension for Inter-Area LSP  
 RFC 5443 LDP IGP Synchronization  
 draft-ietf-mpls-ldp-p2mp-05 LDP Extensions for Point-to-Multipoint and Multipoint-to-Multipoint LSP  
 draft-ietf-mpls-mldp-in-band-signaling-05 Multipoint LDP in-band signaling for Point-to-Multipoint and Multipoint-to-Multipoint Label Switched Paths

### MPLS/RSVP-TE

RFC 2702 Requirements for Traffic Engineering over MPLS  
 RFC2747 RSVP Cryptographic Authentication  
 RFC3097 RSVP Cryptographic Authentication  
 RFC 3209 Extensions to RSVP for Tunnels  
 RFC 3564 Requirements for Diff-Serv-aware TE  
 RFC 3906 Calculating Interior Gateway Protocol (IGP) Routes Over Traffic Engineering Tunnels  
 RFC 4090 Fast reroute Extensions to RSVP-TE for LSP Tunnels  
 RFC 4124 Protocol Extensions for Support of Diffserv-aware MPLS Traffic Engineering  
 RFC 4125 Maximum Allocation Bandwidth Constraints Model for Diffserv-aware MPLS Traffic Engineering  
 RFC 4127 Russian Dolls Bandwidth Constraints Model for Diffserv-aware MPLS Traffic Engineering  
 RFC 4561 Definition of a RRO Node-Id Sub-Object  
 RFC 4875 Extensions to Resource Reservation Protocol - Traffic Engineering (RSVP-TE) for Point-to-Multipoint TE Label Switched Paths (LSPs)  
 RFC 5151 Inter-domain MPLS and GMPLS Traffic Engineering – RSVP-TE Extensions  
 RFC 5712 MPLS Traffic Engineering Soft Preemption

draft-newton-mpls-te-dynamic-overbooking-00 A Diffserv-TE Implementation Model to dynamically change booking factors during failure events  
 RFC 5817 Graceful Shutdown in GMPLS Traffic Engineering Networks

### MPLS — OAM

RFC 4379 Detecting Multi-Protocol Label Switched (MPLS) Data Plane Failures  
 draft-ietf-mpls-p2mp-lsp-ping-06 Detecting Data Plane Failures in Point-to-Multipoint Multiprotocol Label Switching (MPLS) - Extensions to LSP Ping

### RIP

RFC 1058 RIP Version 1  
 RFC 2082 RIP-2 MD5 Authentication  
 RFC 2453 RIP Version 2

### TCP/IP

RFC 768 UDP  
 RFC 1350 The TFTP Protocol (Rev.  
 RFC 791 IP  
 RFC 792 ICMP  
 RFC 793 TCP  
 RFC 826 ARP  
 RFC 854 Telnet  
 RFC 951 BootP (rev)  
 RFC 1519 CIDR  
 RFC 1542 Clarifications and Extensions for the Bootstrap Protocol  
 RFC 1812 Requirements for IPv4 Routers  
 RFC 2347 TFTP option Extension  
 RFC 2328 TFTP Blocksize Option  
 RFC 2349 TFTP Timeout Interval and Transfer Size option  
 RFC 2401 Security Architecture for Internet Protocol  
 RFC 2428 FTP Extensions for IPv6 and NATs  
 RFC 3596 DNS Extensions to Support IP version 6  
 draft-ietf-bfd-mib-00.txtBidirectional Forwarding Detection Management Information Base  
 RFC 5880 Bidirectional Forwarding Detection

RFC 5881 BFD IPv4 and IPv6 (Single Hop)  
 RFC 5883 BFD for Multihop Paths

### VRRP

RFC 2787 Definitions of Managed Objects for the Virtual Router Redundancy Protocol  
 RFC 3768 Virtual Router Redundancy Protocol  
 RFC 5798, Virtual Router Redundancy Protocol Version 3 for IPv4 and IPv6

### PPP

RFC 1332 PPP IPCP  
 RFC 1377 PPP OSINLCP  
 RFC 1638/2878PPP BCP  
 RFC 1661 PPP (rev RFC2151)  
 RFC 1662 PPP in HDLC-like Framing  
 RFC 1877 PPP Internet Protocol Control Protocol Extensions for Name Server Addresses  
 RFC 1989 PPP Link Quality Monitoring  
 RFC 1990 The PPP Multilink Protocol (MP)  
 RFC 1994 PPP Challenge Handshake Authentication Protocol (CHAP)  
 RFC 2615 PPP over SONET/SDH  
 RFC 2516 A Method for Transmitting PPP Over Ethernet  
 RFC 2686 The Multi-Class Extension to Multi-Link PPP

### Frame Relay

FRF.1.2 - PVC User-to-Network Interface (UNI) Implementation Agreement  
 FRF.5 - Frame Relay/ATM PVC Network Interworking Implementation  
 ANSI T1.617 Annex D, DSS1 — Signalling Specification For Frame Relay Bearer Service.  
 FRF2.2 -PVC Network-to- Network Interface (NNI) Implementation Agreement.  
 FRF.12 Frame Relay Fragmentation Implementation Agreement  
 FRF.16.1 Multilink Frame Relay UNI/ NNI Implementation Agreement  
 ITU-T Q.933 Annex A- Additional procedures for Permanent Virtual Connection (PVC) status management

## Standards and Protocols

### ATM

- RFC 1626 Default IP MTU for use over ATM AAL5
- RFC 2514 Definitions of Textual Conventions and OBJECT\_IDENTITIES for ATM Management
- RFC 2515 Definition of Managed Objects for ATM Management RFC 2684 Multiprotocol Encapsulation over ATM Adaptation Layer 5
- AF-TM-0121.000 Traffic Management Specification Version 4.1
- ITU-T Recommendation I.610 - B-ISDN Operation and Maintenance Principles and Functions version 11/95
- ITU-T Recommendation I.432.1 – BISDN user-network interface – Physical layer specification: General characteristics
- GR-1248-CORE - Generic Requirements for Operations of ATM Network Elements (NEs). Issue 3
- GR-1113-CORE - Bellcore, Asynchronous Transfer Mode (ATM) and ATM Adaptation Layer (AAL) Protocols Generic Requirements, Issue 1
- AF-ILMI-0065.000 Integrated Local Management Interface (ILMI) Version 4.0
- AF-TM-0150.00 Addendum to Traffic Management v4.1 optional minimum desired cell rate indication for UBR
- AF-PHY-0086.001, Inverse Multiplexing for ATM (IMA) Specification Version 1.1

### DHCP

- RFC 2131 Dynamic Host Configuration Protocol (REV)
- RFC 3046 DHCP Relay Agent Information Option (Option 82)
- RFC 1534 Interoperation between DHCP and BOOTP

### VPLS

- RFC 4762 Virtual Private LAN Services Using LDP
- RFC5501: Requirements for Multicast Support in Virtual Private LAN

- Services (previously draft-ietf-l2vpn-vpls-mcast-reqts-04)
- draft-ietf-l2vpn-vpls-mcast-reqts-04
- draft-ietf-l2vpn-signaling-08

### PSEUDOWIRE

- RFC 3985 Pseudo Wire Emulation Edge-to-Edge (PWE3)
- RFC 4385 Pseudo Wire Emulation Edge-to-Edge (PWE3) Control Word for Use over an MPLS PSN
- RFC 3916 Requirements for Pseudo-Wire Emulation Edge-to-Edge (PWE3)
- RFC 4717 Encapsulation Methods for Transport ATM over MPLS Networks (draft-ietf-pwe3-atm-encap-10.txt)
- RFC 4816 PWE3 ATM Transparent Cell Transport Service (draft-ietf-pwe3-cell-transport-04.txt)
- RFC 4448 Encapsulation Methods for Transport of Ethernet over MPLS Networks (draft-ietf-pwe3-ethernet-encap-11.txt)
- RFC 4619 Encapsulation Methods for Transport of Frame Relay over MPLS Networks (draft-ietf-pwe3-frame-relay-07.txt)
- RFC 4446 IANA Allocations for PWE3
- RFC 4447 Pseudowire Setup and Maintenance Using LDP (draft-ietf-pwe3-control-protocol-17.txt)
- RFC 5085, Pseudowire Virtual Circuit Connectivity Verification (VCCV): A Control Channel for Pseudowires
- RFC 5659 An Architecture for Multi-Segment Pseudowire Emulation Edge-to-Edge
- draft-ietf-l2vpn-vpws-iw-oam-02.txt, OAM Procedures for VPWS Interworking
- RFC6310, Pseudowire (PW) OAM Message Mapping
- draft-ietf-l2vpn-arp-mediation-19.txt, ARP Mediation for IP Interworking of Layer 2 VPN
- RFC6073, Segmented Pseudowire (draft-ietf-pwe3-segmented-pw-18.txt)
- draft-ietf-pwe3-dynamic-ms-pw-14.txt, Dynamic Placement of Multi Segment Pseudo Wires

- draft-ietf-pwe3-redundancy-bit-06.txt, Pseudowire Preferential Forwarding Status bit definition
- draft-ietf-pwe3-redundancy-06.txt, Pseudowire (PW) Redundancy
- RFC6391 Flow Aware Transport of Pseudowires over an MPLS PSN
- MFA Forum 9.0.0 The Use of Virtual trunks for ATM/MPLS Control Plane Interworking
- MFA Forum 12.0.0 Multiservice Interworking - Ethernet over MPLS
- MFA forum 13.0.0 - Fault Management for Multiservice Interworking v1.0
- MFA Forum 16.0.0 – Multiservice Interworking - IP over MPLS

### ANCP/L2CP

- RFC5851 ANCP framework
- draft-ietf-ancp-protocol-02.txt ANCP Protocol

### Voice /Video Performance

- ITU-T G.107 The E Model- A computational model for use in planning.
- ETSI TS 101 329-5 Annex E extensions- QoS Measurement for VoIP - Method for determining an Equipment Impairment Factor using Passive Monitoring
- ITU-T Rec. P.564 - Conformance testing for voice over IP transmission quality assessment models
- ITU-T G.1020 - Appendix I - Performance Parameter Definitions for Quality of Speech and other Voiceband Applications Utilizing IP Networks- Mean Absolute Packet Delay Variation.& Markov Models.
- RFC 3550 Appendix A.8- RTP: A Transport Protocol for Real-Time Applications- Estimating the Interarrival Jitter

### CIRCUIT EMULATION

- RFC 4553 Structure-Agnostic Time Division Multiplexing (TDM) over Packet (SAToP)
- RFC 5086 Structure-Aware Time Division Multiplexed (TDM) Circuit Emulation Service over Packet Switched Network (CESoPSN)

MEF-8 Implementation Agreement for the Emulation of PDH Circuits over Metro Ethernet Networks, October 2004

RFC 5287 Control Protocol Extensions for the Setup of Time-Division Multiplexing (TDM) Pseudowires in MPLS Networks

### SONET/SDH

ITU-G.841 Telecommunication Standardization Section of ITU, Types and Characteristics of SDH Networks Protection Architecture, issued in October 1998 and as augmented by Corrigendum1 issued in July 2002

### RADIUS

RFC 2865 Remote Authentication Dial In User Service

RFC 2866 RADIUS Accounting

### SSH

RFC 4250 The Secure Shell (SSH) Protocol

draft-ietf-secsh-architecture.txt SSH Protocol Architecture

draft-ietf-secsh-userauth.txt SSH Authentication Protocol

draft-ietf-secsh-transport.txt SSH Transport Layer Protocol

draft-ietf-secsh-connection.txt SSH Connection Protocol

draft-ietf-secsh-newmodes.txt SSH Transport Layer Encryption Modes

### TACACS+

draft-grant-tacacs-02.txt

### Timing

GR-253-CORE SONET Transport Systems: Common Generic Criteria. Issue 3, September 2000

ITU-T G.781 Telecommunication Standardization Section of ITU, Synchronization layer functions, issued 09/2008

ITU-T G.813 Telecommunication Standardization Section of ITU, Timing characteristics of SDH equipment slave clocks (SEC), issued 03/2003.

GR-1244-CORE Clocks for the Synchronized Network: Common Generic Criteria, Issue 3, May 2005

ITU-T G.8261 Telecommunication Standardization Section of ITU, Timing and synchronization aspects in packet networks, issued 04/2008.

ITU-T G.8262 Telecommunication Standardization Section of ITU, Timing characteristics of synchronous Ethernet equipment slave clock (EEC), issued 08/2007.

ITU-T G.8264 Telecommunication Standardization Section of ITU, Distribution of timing information through packet networks, issued 10/2008.

### NETWORK MANAGEMENT

ITU-T X.721: Information technology-OSI-Structure of Management Information

ITU-T X.734: Information technology-OSI-Systems Management: Event Report Management Function

M.3100/3120 Equipment and Connection Models

TMF 509/613 Network Connectivity Model

RFC 1157 SNMPv1

RFC 1215 A Convention for Defining Traps for use with the SNMP

RFC 1657 BGP4-MIB

RFC 1724 RIPv2-MIB

RFC 1850 OSPF-MIB

RFC 1907 SNMPv2-MIB

RFC 2011 IP-MIB

RFC 2012 TCP-MIB

RFC 2013 UDP-MIB

RFC 2138 RADIUS

RFC 2206 RSVP-MIB

RFC 2452 IPv6 Management Information Base for the Transmission Control Protocol

RFC 2454 IPv6 Management Information Base for the User Datagram Protocol

RFC 2465 Management Information Base for IPv6: Textual Conventions and General Group

RFC 2558 SONET-MIB

RFC 2571 SNMP-Framework MIB

RFC 2572 SNMP-MPD-MIB

RFC 2573 SNMP-Target-&-notification-MIB

RFC 2574 SNMP-User-based-SMMIB

RFC 2575 SNMP-View-based ACM-MIB

RFC 2576 SNMP-Community-MIB

RFC 2665 EtherLike-MIB

RFC 2819 RMON-MIB

RFC 2863 IF-MIB

RFC 2864 Inverted-stack-MIB

RFC 2987 VRRP-MIB

RFC 3014 Notification-log MIB

RFC 3019 IP Version 6 Management Information Base for The Multicast Listener Discovery Protocol

RFC 3164 Syslog

RFC 3273 HCRMON-MIB

RFC 3411 An Architecture for Describing Simple Network Management Protocol (SNMP) Management Frameworks

RFC 3412 Message Processing and Dispatching for the Simple Network Management Protocol (SNMP)

RFC 3413 Simple Network Management Protocol (SNMP) Applications

RFC 3414 User-based Security Model (USM) for version 3 of the Simple Network Management Protocol (SNMPv3)

RFC 3418 SNMP MIB

RFC 4292 IP-Forward-MIB

RFC 4293 MIB for the Internet Protocol

RFC 5101 Specification of the IP Flow Information Export (IPFIX) Protocol for the Exchange of IP Traffic Flow Information

draft-ietf-ospf-mib-update-04.txt

draft-ietf-mpls-lsr-mib-06.txt

draft-ietf-mpls-te-mib-04.txt

draft-ietf-mpls-ldp-mib-07.txt

draft-ietf-isis-wg-mib-05.txt

IANA-IFTType-MIB

IEEE8023-LAG-MIB

### Proprietary MIBs

TIMETRA-APS-MIB.mib

TIMETRA-ATM-MIB.mib

TIMETRA-BGP-MIB.mib

TIMETRA-BSX-NG-MIB.mib

TIMETRA-CAPABILITY-7750-V4v0.mib

## Standards and Protocols

TIMETRA-CFLOWD-MIB.mib  
TIMETRA-CHASSIS-MIB.mib  
TIMETRA-CLEAR-MIB.mib  
TIMETRA-FILTER-MIB.mib  
TIMETRA-GLOBAL-MIB.mib  
TIMETRA-IGMP-MIB.mib  
TIMETRA-ISIS-MIB.mib  
TIMETRA-LAG-MIB.mib  
TIMETRA-LDP-MIB.mib  
TIMETRA-LOG-MIB.mib  
TIMETRA-MIRROR-MIB.mib  
TIMETRA-MPLS-MIB.mib  
TIMETRA-NG-BGP-MIB.mib  
TIMETRA-OAM-TEST-MIB.mib  
TIMETRA-OSPF-NG-MIB.mib  
TIMETRA-OSPF-V3-MIB.mib  
TIMETRA-PIM-NG-MIB.mib  
TIMETRA-PORT-MIB.mib  
TIMETRA-PPP-MIB.mib  
TIMETRA-QOS-MIB.mib  
TIMETRA-RIP-MIB.mib  
TIMETRA-ROUTE-POLICY-MIB.mib  
TIMETRA-RSVP-MIB.mib  
TIMETRA-SECURITY-MIB.mib  
TIMETRA-SERV-MIB.mib  
TIMETRA-SUBSCRIBER-  
MGMTMIB.mib  
TIMETRA-SYSTEM-MIB.mib  
TIMETRA-TC-MIB.mib  
TIMETRA-VRRP-MIB.mib  
TIMETRA-VRTR-MIB.mib

# Index

## B

### BGP

- overview 566
  - confederations 577
  - group configuration and peers 568
  - hierarchical levels 569
  - interactions and dependencies 593
  - message types 566
  - route damping 596, 569
- configuring 610
  - autonomous system 613
  - basic 610
  - BGP parameters
    - group 620
    - neighbor 621
  - command reference 629, 623
  - overview 608
  - route reflection 617, 622, 614
  - management tasks 624

## I

### IP Router

- configuring
  - basic 67
  - service management tasks 87

### IS-IS

- overview 442
  - ISO network addressing 446
  - PDU configuration 448
  - routing 443
  - terminology 445
- configuring
  - area address attributes 462
  - basic 465
  - command reference 521
  - enabling IS-IS 468
  - global parameters 471
  - interface level capabilities 463, 476
  - ISO area addresses 470
  - level parameters 468
  - management tasks 481
  - overview 462

router levels 462

## M

### Multicast 21

- IGMP 27
- PIM 30

## O

### OSPF

- overview 288
  - AS areas 289
    - backbone 289
    - NSSA 291
    - stub 290
  - authentication 303
  - IP subnets 304
  - LSAs 302
  - metrics 302
  - neighbors and adjacencies 301
  - virtual links 300
- configuring 317
  - area interface 328, 331
  - basic 317
  - command reference 347
  - designated router 334
  - management tasks 341
  - NSSA 324
  - OSPF area 321
  - overview 316
  - route preferences 338, 336, 318
  - stub area 322
  - virtual link 326

## R

### RIP

- overview 234
  - authentication 235
  - hierarchy 239
  - import/export policies 236
  - metrics 236
  - packet format 237

## Index

- ripv1 238
- timers 236
- version types 235
- configuring
  - basic 245
  - command reference 257
  - interfaces 247
  - management tasks 255
  - overview 244
  - RIP parameters 250
    - global 252, 253
    - neighbor 254
  - route policy 248
- Route policies
  - overview 732
    - damping 755, 751
    - policy evaluation 752, 733
    - regular expressions 737
    - when to use 746
  - configuring
    - beginning 759
    - command reference 773, 763, 760
    - damping 764, 761
    - entry 762
    - management tasks 769
    - overview 750
    - prefix list 765