

Multicast VPN: Sender-Only, Receiver-Only

In This Chapter

This section provides information about multicast VPN sender-only and receiver-only configurations.

Topics in this section include:

- [Applicability on page 750](#)
- [Summary on page 751](#)
- [Overview on page 752](#)
- [Overview on page 752](#)
- [Conclusion on page 800](#)

Applicability

This example is applicable to 7950 XRS, 7750 all variants, 7750 SR c4/12 and 7450 mixed mode systems. Chassis mode C or higher must be used. The configuration was tested on release 11.0R3.

Summary

This example covers a basic technology overview, the network topology and configuration examples which are used for the Multicast VPN (MVPN) sender-only, receiver-only feature.

Knowledge of the Alcatel-Lucent multicast and Layer 3 VPNs concepts are assumed throughout this document.

Overview

By default, if multiple PE nodes form a peering relationship with a common MVPN instance then each PE node originates a multicast tree locally towards the remaining PE nodes that are members of this MVPN instance. This behavior creates a full mesh of Inclusive-Provider Multicast Service Interfaces (I-PMSIs) across all PE nodes in the MVPN.

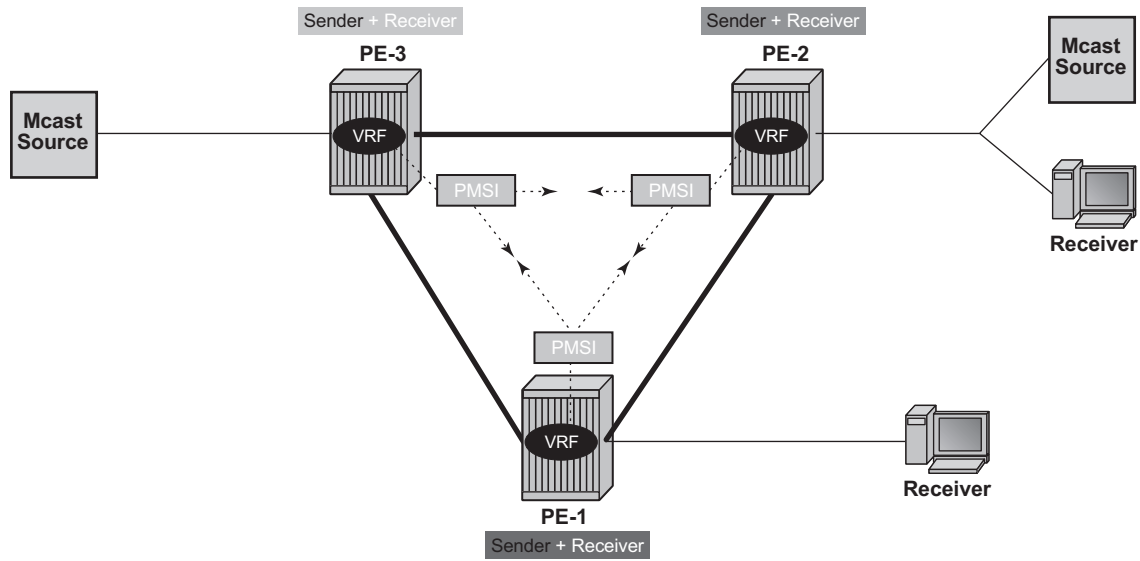

Figure 100: Default PMSI Hierarchy

It is often a case that a given MVPN has many sites with multicast receivers, but only a few sites that host either both receivers and sources, or sources only.

The MVPN sender-only/receiver-only feature optimizes control and data plane resources by preventing unnecessary I-PMSI meshing when a given PE hosts multicast sources only, or multicast receivers only, for a given MVPN. An example of such an optimization is presented in [Figure 101](#).

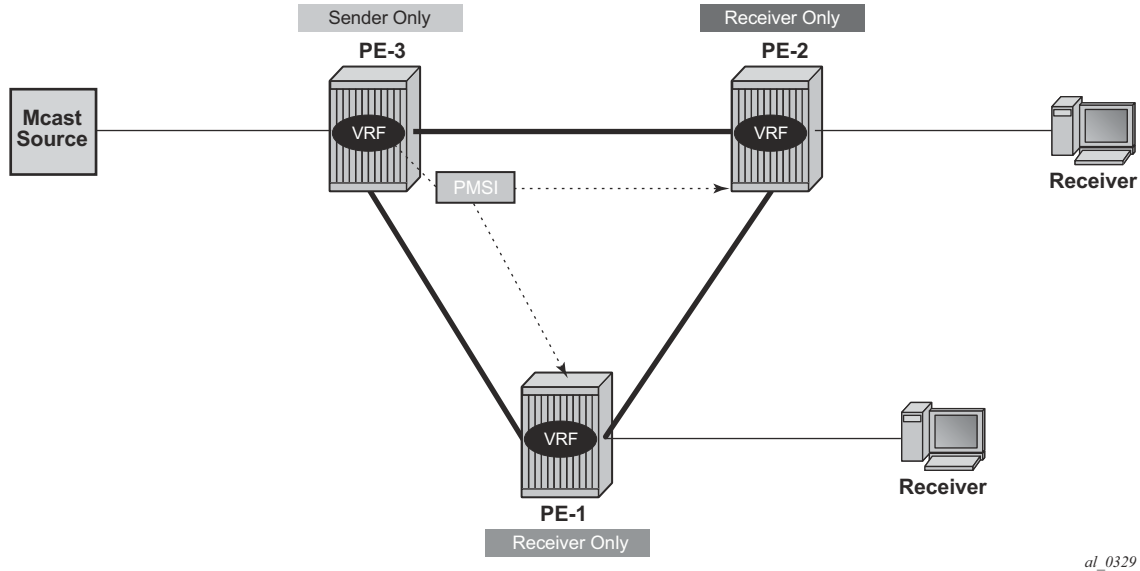

Figure 101: Optimized PMSI Structure

The general rules to follow are:

- For PE nodes that host only multicast sources for a given MVPN, operators can now block PEs, through configuration, from joining I-PMSIs from other PEs in this MVPN.
- For PE nodes that host only multicast receivers for a given MVPN, operators can now block PEs, through configuration, to set-up a local I-PMSI to other PEs in this MVPN.

MVPN sender-only/receiver-only is supported with next generation-MVPN for both IPv4 and IPv6 customer multicast using:

- IPv4 RSVP-TE provider tunnels
- IPv4 LDP provider tunnels

Note: Extra attention should be given to the Bootstrap Router/Rendezvous Point (BSR/RP) placement when sender-only/receiver-only is enabled:

- The RP should be at sender-receiver or sender-only site so that $(*,G)^1$ traffic can be sent over the tunnel
- The BSR should be deployed at the sender-receiver site.
- The BSR can be at a sender-only site if the RPs are at the same site.

1. $*,G$ refers to an individual multicast stream indicating any source (*) and the multicast group (G) used by the stream.

Configuration

The test topology is shown in Figure 102.

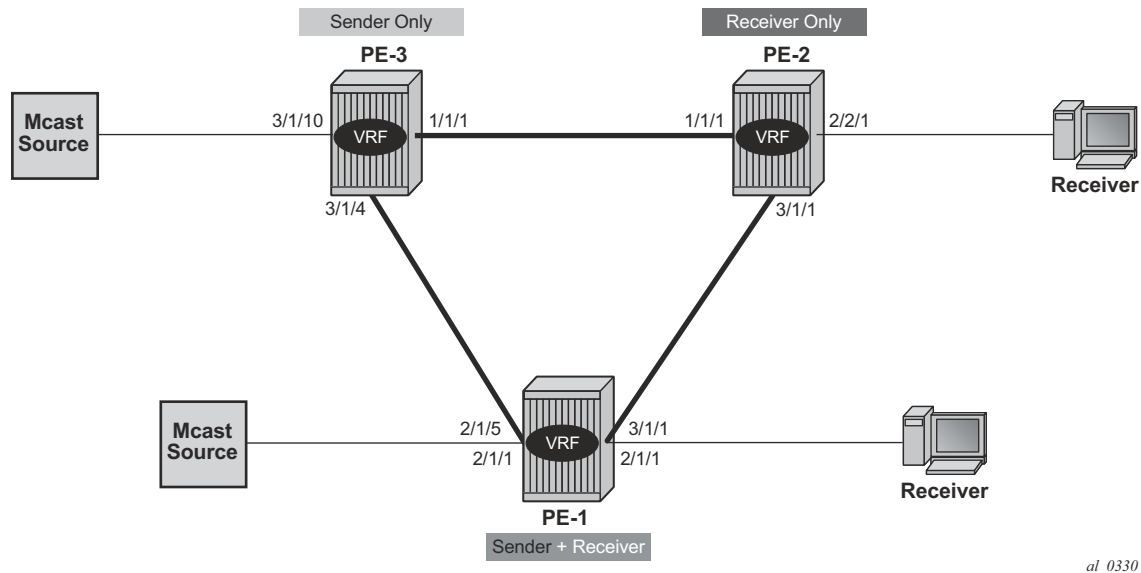

al_0330

Figure 102: Test Topology

To configure the sender-only/receiver-only feature the following configuration command is used:

```
*A:PE>config>service>vprn>mvpn# mdt-type
  - mdt-type {sender-only|receiver-only|sender-receiver}
  - no mdt-type
```

sender-receiver is the default option and is visible using the **info detail** command.

This command restricts the MVPN instance per PE node to a specific role and provides an option to configure either a sender-only or receiver-only mode per PE node per service.

Parameters:

sender-only — MVPN has only senders connected to PE node.

receiver-only — MVPN has only receivers connected to PE node.

sender-receiver — MVPN has both sender and receivers connected to PE node.

Considerations:

- Two general approaches for building MVPNs will be covered in detail in this example:
 - Point-to-multipoint (P2MP) RSVP MVPNs
 - Multicast LDP (mLDP) MVPNs
- IPv4 and IPv6 multicast streaming are used for every MVPN at the same time.
- Basic principles of an MVPN including I-PMSI, S-PMSI, mLDP and P2MP RSVP are covered in the [Multicast in a VPN I on page 635](#) and chapters of this guide.

PIM SSM is used for IPv4/IPv6 Customer (C)-multicast groups.

RSVP-Based MVPN Configuration

Step 0. Configure a basic MVPN using P2MP RSVP as a transport protocol for C-multicast groups. For this setup PE-1 and PE-2 are configured to receive the following multicast groups:

- IPv4 group 232.0.0.1 source 172.16.3.1
- IPv6 group FF3E::8000:1 source 2001:DB8:3::1

Step 1. Configure the MDT type for the MVPN.

Based on the test topology, PE-3 is configured as **sender-only** for the MVPN.

```
*A:PE-3>config>service>vprn# info
-----
<snip>
description "RSVP based MVPN"
interface "int-mcast-source" create
  description "10G STC port 12/2"
  address 172.16.3.2/30
  ipv6
    address 2001:DB8:3::2/127
  exit
  sap 3/1/10:3.1001 create
  exit
exit
pim
  no ipv6-multicast-disable
  apply-to all
  rp
    static
    exit
    bsr-candidate
      shutdown
    exit
    rp-candidate
      shutdown
    exit
  exit
  no shutdown
exit
mvpn
  auto-discovery default
  c-mcast-signaling bgp
  mdt-type sender-only
  provider-tunnel
    inclusive
    rsvp
      lsp-template "mvpn-p2mp-lsp"
      no shutdown
    exit
  exit
exit
vrf-target unicast
exit
```



```

    exit
    service-name "RSVP based MVPN"
<snip>

```

Based on the test topology PE-2 is configured as **receiver-only** for the MVPN. PE-2 has also static joins for the IPv4 and IPv6 multicast groups:

- group 232.0.0.1, source 172.16.3.1
- group FF3E::8000:1, source 2001:DB8:3::1

```

*A:PE-2>config>service>vprn# info
-----
    description "RSVP based MVPN"
<snip>
    interface "int-mcast-receiver" create
        description "10G STC port 10/2"
        address 172.16.2.2/30
        ipv6
            address 2001:DB8:2::2/127
        exit
        sap 2/2/1:3.1001 create
        exit
    exit
    igmp
        interface "int-mcast-receiver"
            static
                group 232.0.0.1
                source 172.16.3.1
            exit
        exit
        no shutdown
    exit
    no shutdown
    exit
    mld
        interface "int-mcast-receiver"
            static
                group FF3E::8000:1
                source 2001:DB8:3::1
            exit
        exit
        no shutdown
    exit
    no shutdown
    exit
    pim
        no ipv6-multicast-disable
        rp
            static
                exit
            bsr-candidate
                shutdown
            exit
            rp-candidate
                shutdown
            exit

```

RSVP-Based MVPN Configuration

```
        exit
        no shutdown
    exit
    mvpn
        auto-discovery default
        c-mcast-signaling bgp
        mdt-type receiver-only
        provider-tunnel
            inclusive
            rsvp
                lsp-template "mvpn-p2mp-lsp"
                no shutdown
            exit
        exit
    exit
    vrf-target unicast
    exit
exit
service-name "RSVP based MVPN"
<snip>
```

Based on the test topology, PE-1 is configured as **sender-receiver** (default) for the MVPN. PE-1 has also static joins for the IPv4 and IPv6 multicast groups:

- group 232.0.0.1, source 172.16.3.1
- group FF3E::8000:1, source 2001:DB8:3::1

```
*A:PE-1>config>service>vprn# info
-----
description "RSVP based MVPN"
<snip>
interface "int-mcast-receiver" create
description "10G STC port 10/1"
address 172.16.1.2/30
ipv6
    address 2001:DB8:1::2/127
exit
sap 2/1/1:3.1001 create
exit
exit
igmp
interface "int-mcast-receiver"
static
    group 232.0.0.1
    source 172.16.3.1
    exit
exit
no shutdown
exit
no shutdown
exit
mld
interface "int-mcast-receiver"
static
    group FF3E::8000:1
    source 2001:DB8:3::1
```

```

        exit
        exit
        no shutdown
    exit
    no shutdown
exit
pim
    no ipv6-multicast-disable
    apply-to all
    rp
        static
        exit
        bsr-candidate
            shutdown
        exit
        rp-candidate
            shutdown
        exit
    exit
    no shutdown
exit
mvpn
    auto-discovery default
    c-mcast-signaling bgp
    provider-tunnel
        inclusive
        rsvp
            lsp-template "mvpn-p2mp-lsp"
            no shutdown
        exit
    exit
    vrf-target unicast
    exit
exit
service-name "RSVP based MVPN"
no shutdown

```

Note: The PIM instance must be **shutdown** before the mdt-type is modified; this leads to a multicast service disruption. Trying to change the mdt-type with PIM instance active will result in the message below being displayed.

```

*A:PE-1>config>service>vprn>mvpn# mdt-type sender-only
MINOR: PIM #1100 PIM instance must be shutdown before changing this configuration

```

RSVP-Based MVPN Verification and Debugging

MDT-Type Verification

The status of the MVPN can be checked using the **show>router <service-number> mvpn** command:

PE-1 output:

```
A:PE-1# show router 1 mvpn
=====
MVPN 1 configuration data
=====
signaling          : Bgp                auto-discovery    : Default
UMH Selection      : Highest-Ip           intersite-shared   : Enabled
vrf-import         : N/A
vrf-export         : N/A
vrf-target         : unicast
C-Mcast Import RT : target:192.0.2.1:3

ipmsi              : rsvp mvpn-p2mp-lsp
i-pmsi P2MP AdmSt  : Up
i-pmsi Tunnel Name : mvpn-p2mp-lsp-1-73741
enable-bfd-root    : false                enable-bfd-leaf   : false
Mdt-type           : sender-receiver

s-pmsi             : none
data-delay-interval : 3 seconds
enable-asm-mdt     : N/A
=====
```

PE-2 output:

```
A:PE-2# show router 1 mvpn
=====
MVPN 1 configuration data
=====
signaling          : Bgp                auto-discovery    : Default
UMH Selection      : Highest-Ip           intersite-shared   : Enabled
vrf-import         : N/A
vrf-export         : N/A
vrf-target         : unicast
C-Mcast Import RT : target:192.0.2.2:1905

ipmsi              : rsvp mvpn-p2mp-lsp
i-pmsi P2MP AdmSt  : Up
i-pmsi Tunnel Name : mpls-virt-if-640323
enable-bfd-root    : false                enable-bfd-leaf   : false
Mdt-type           : receiver-only

s-pmsi             : none
data-delay-interval : 3 seconds
```

enable-asm-mdt : N/A

PE-3 output:

*A:PE-3# show router 1 mvpn

MVPN 1 configuration data

```

=====
signaling          : Bgp          auto-discovery    : Default
UMH Selection      : Highest-Ip    intersite-shared   : Enabled
vrf-import         : N/A
vrf-export         : N/A
vrf-target         : unicast
C-Mcast Import RT : target:192.0.2.3:2086
    
```

```

ipmsi              : rsvp mvpn-p2mp-lsp
i-pmsi P2MP AdmSt  : Up
i-pmsi Tunnel Name : mvpn-p2mp-lsp-1-73741
enable-bfd-root    : false        enable-bfd-leaf   : false
Mdt-type           : sender-only
    
```

```

s-pmsi             : none
data-delay-interval: 3 seconds
enable-asm-mdt     : N/A
=====
    
```

BGP Verification and Debugging

When the MDT type is changed, the BGP signaling is slightly modified in order to achieve the signaling optimization.

The PE router does not include the PMSI part in Intra-AD BGP messages when the MVPN is configured with mdt-type as **receiver-only**. The message flow is presented in [Figure 103](#).

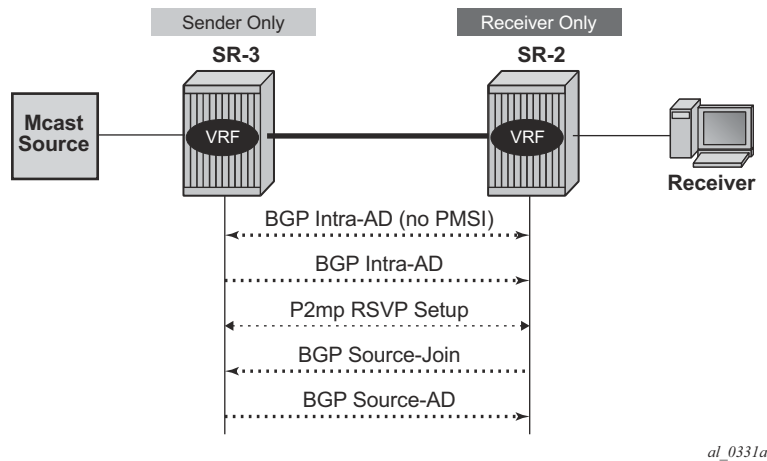

Figure 103: RSVP-Based BGP Message Flow Between PE-2 and PE-3

The BGP debug output below is taken from PE-2 and demonstrates the message flow between PE-2 and PE-3 for MVPN-IPv4 address family.

Note that there is no PMSI part in debug message 62, but the PMSI part is present in message 57, which is sent by PE-3 (**sender-only**).

```
57 2013/10/21 16:58:09.43 CEST MINOR: DEBUG #2001 Base Peer 1: 192.0.2.3
"Peer 1: 192.0.2.3: UPDATE
Peer 1: 192.0.2.3 - Received BGP UPDATE:
  Withdrawn Length = 0
  Total Path Attr Length = 86
  Flag: 0x90 Type: 14 Len: 23 Multiprotocol Reachable NLRI:
    Address Family MVPN_IPV4
    NextHop len 4 NextHop 192.0.2.3
    Type: Intra-AD Len: 12 RD: 64500:103 Orig: 192.0.2.3
  Flag: 0x40 Type: 1 Len: 1 Origin: 0
  Flag: 0x40 Type: 2 Len: 0 AS Path:
  Flag: 0x80 Type: 4 Len: 4 MED: 0
  Flag: 0x40 Type: 5 Len: 4 Local Preference: 100
  Flag: 0xc0 Type: 8 Len: 4 Community:
    no-export
  Flag: 0xc0 Type: 16 Len: 8 Extended Community:
    target:64500:1
```

Multicast VPN: Sender-Only, Receiver-Only

```
Flag: 0xc0 Type: 22 Len: 17 PMSI:
  Tunnel-type RSVP-TE P2MP LSP (1)
  Flags [Leaf not required]
  MPLS Label 0
  P2MP-ID 0x7919, Tunnel-ID: 62688, Extended-Tunnel-ID 192.0.2.3
"

62 2013/10/21 16:58:10.35 CEST MINOR: DEBUG #2001 Base Peer 1: 192.0.2.3
"Peer 1: 192.0.2.3: UPDATE
Peer 1: 192.0.2.3 - Send BGP UPDATE:
  Withdrawn Length = 0
  Total Path Attr Length = 66
  Flag: 0x90 Type: 14 Len: 23 Multiprotocol Reachable NLRI:
    Address Family MVPN_IPV4
    NextHop len 4 NextHop 192.0.2.2
    Type: Intra-AD Len: 12 RD: 64500:102 Orig: 192.0.2.2
  Flag: 0x40 Type: 1 Len: 1 Origin: 0
  Flag: 0x40 Type: 2 Len: 0 AS Path:
  Flag: 0x80 Type: 4 Len: 4 MED: 0
  Flag: 0x40 Type: 5 Len: 4 Local Preference: 100
  Flag: 0xc0 Type: 8 Len: 4 Community:
    no-export
  Flag: 0xc0 Type: 16 Len: 8 Extended Community:
    target:64500:1
"

67 2013/10/21 16:58:10.65 CEST MINOR: DEBUG #2001 Base Peer 1: 192.0.2.3
"Peer 1: 192.0.2.3: UPDATE
Peer 1: 192.0.2.3 - Send BGP UPDATE:
  Withdrawn Length = 0
  Total Path Attr Length = 69
  Flag: 0x90 Type: 14 Len: 33 Multiprotocol Reachable NLRI:
    Address Family MVPN_IPV4
    NextHop len 4 NextHop 192.0.2.2
    Type: Source-Join Len:22 RD: 64500:103 SrcAS: 64500 Src: 172.16.3.1
  Grp: 232.0.0.1
  Flag: 0x40 Type: 1 Len: 1 Origin: 0
  Flag: 0x40 Type: 2 Len: 0 AS Path:
  Flag: 0x80 Type: 4 Len: 4 MED: 0
  Flag: 0x40 Type: 5 Len: 4 Local Preference: 100
  Flag: 0xc0 Type: 16 Len: 8 Extended Community:
    target:192.0.2.3:2086
"

72 2013/10/21 16:58:11.31 CEST MINOR: DEBUG #2001 Base Peer 1: 192.0.2.3
"Peer 1: 192.0.2.3: UPDATE
Peer 1: 192.0.2.3 - Received BGP UPDATE:
  Withdrawn Length = 0
  Total Path Attr Length = 65
  Flag: 0x90 Type: 14 Len: 29 Multiprotocol Reachable NLRI:
    Address Family MVPN_IPV4
    NextHop len 4 NextHop 192.0.2.3
    Type: Source-AD Len: 18 RD: 64500:103 Src: 172.16.3.1 Grp: 232.0.0.1
  Flag: 0x40 Type: 1 Len: 1 Origin: 0
  Flag: 0x40 Type: 2 Len: 0 AS Path:
  Flag: 0x80 Type: 4 Len: 4 MED: 0
  Flag: 0x40 Type: 5 Len: 4 Local Preference: 100
  Flag: 0xc0 Type: 16 Len: 8 Extended Community:
    target:64500:1
```

RSVP-Based MVPN Configuration

"

Similar behavior is observed for IPv6 multicast. The BGP debug output below is taken from PE-2 and demonstrates the message flow between PE-2 and PE-3 for the MVPN-IPv6 address family.

Note that there is no PMSI part in debug message 63.

```
58 2013/10/21 16:58:09.42 CEST MINOR: DEBUG #2001 Base Peer 1: 192.0.2.3
"Peer 1: 192.0.2.3: UPDATE
Peer 1: 192.0.2.3 - Received BGP UPDATE:
  Withdrawn Length = 0
  Total Path Attr Length = 86
  Flag: 0x90 Type: 14 Len: 23 Multiprotocol Reachable NLRI:
    Address Family MVPN_IPV6
    NextHop len 4 NextHop 192.0.2.3
    Type: Intra-AD Len: 12 RD: 64500:103 Orig: 192.0.2.3
  Flag: 0x40 Type: 1 Len: 1 Origin: 0
  Flag: 0x40 Type: 2 Len: 0 AS Path:
  Flag: 0x80 Type: 4 Len: 4 MED: 0
  Flag: 0x40 Type: 5 Len: 4 Local Preference: 100
  Flag: 0xc0 Type: 8 Len: 4 Community:
    no-export
  Flag: 0xc0 Type: 16 Len: 8 Extended Community:
    target:64500:1
  Flag: 0xc0 Type: 22 Len: 17 PMSI:
    Tunnel-type RSVP-TE P2MP LSP (1)
    Flags [Leaf not required]
    MPLS Label 0
    P2MP-ID 0x7919, Tunnel-ID: 62688, Extended-Tunnel-ID 192.0.2.3
"

63 2013/10/21 16:58:10.34 CEST MINOR: DEBUG #2001 Base Peer 1: 192.0.2.3
"Peer 1: 192.0.2.3: UPDATE
Peer 1: 192.0.2.3 - Send BGP UPDATE:
  Withdrawn Length = 0
  Total Path Attr Length = 66
  Flag: 0x90 Type: 14 Len: 23 Multiprotocol Reachable NLRI:
    Address Family MVPN_IPV6
    NextHop len 4 NextHop 192.0.2.2
    Type: Intra-AD Len: 12 RD: 64500:102 Orig: 32.1.13.184
  Flag: 0x40 Type: 1 Len: 1 Origin: 0
  Flag: 0x40 Type: 2 Len: 0 AS Path:
  Flag: 0x80 Type: 4 Len: 4 MED: 0
  Flag: 0x40 Type: 5 Len: 4 Local Preference: 100
  Flag: 0xc0 Type: 8 Len: 4 Community:
    no-export
  Flag: 0xc0 Type: 16 Len: 8 Extended Community:
    target:64500:1
"

66 2013/10/21 16:58:10.65 CEST MINOR: DEBUG #2001 Base Peer 1: 192.0.2.3
"Peer 1: 192.0.2.3: UPDATE
Peer 1: 192.0.2.3 - Send BGP UPDATE:
  Withdrawn Length = 0
  Total Path Attr Length = 93
  Flag: 0x90 Type: 14 Len: 57 Multiprotocol Reachable NLRI:
    Address Family MVPN_IPV6
    NextHop len 4 NextHop 192.0.2.2
    Type: Source-Join Len: 46 RD: 64500:103 SrcAS: 64500 Src: 2001:DB8:3
::1 Grp: FF3E::8000:1
```

Multicast VPN: Sender-Only, Receiver-Only

```

Flag: 0x40 Type: 1 Len: 1 Origin: 0
Flag: 0x40 Type: 2 Len: 0 AS Path:
Flag: 0x80 Type: 4 Len: 4 MED: 0
Flag: 0x40 Type: 5 Len: 4 Local Preference: 100
Flag: 0xc0 Type: 16 Len: 8 Extended Community:
    target:192.0.2.3:2086
"

71 2013/10/21 16:58:11.30 CEST MINOR: DEBUG #2001 Base Peer 1: 192.0.2.3
"Peer 1: 192.0.2.3: UPDATE
Peer 1: 192.0.2.3 - Received BGP UPDATE:
Withdrawn Length = 0
Total Path Attr Length = 89
Flag: 0x90 Type: 14 Len: 53 Multiprotocol Reachable NLRI:
    Address Family MVPN_IPV6
    NextHop len 4 NextHop 192.0.2.3
    Type: Source-AD Len: 42 RD: 64500:103 Src: 2001:DB8:3::1 Grp: FF3E
::8000:1
Flag: 0x40 Type: 1 Len: 1 Origin: 0
Flag: 0x40 Type: 2 Len: 0 AS Path:
Flag: 0x80 Type: 4 Len: 4 MED: 0
Flag: 0x40 Type: 5 Len: 4 Local Preference: 100
Flag: 0xc0 Type: 16 Len: 8 Extended Community:
    target:64500:1
"

```

The PE router does not change its BGP behavior when the MVPN is configured with `mdt-type` as **sender-only**. The message flow is presented in [Figure 104](#).

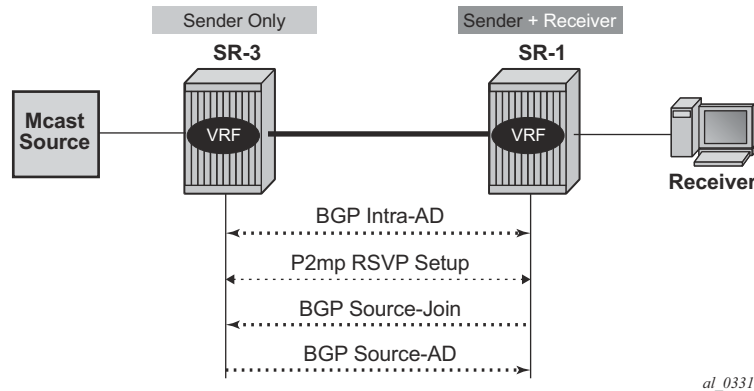

Figure 104: RSVP-Based BGP Message Flow Between PE-1 and PE-3

The BGP debug output below is taken from PE-1 and demonstrates the message flow between PE-1 and PE-3 for the MVPN-IPv4 address family.

Note that the PMSI part is present in debug message 107, which is sent by PE-3 (**sender-only**).

RSVP-Based MVPN Configuration

```
107 2013/10/21 16:58:09.43 CEST MINOR: DEBUG #2001 Base Peer 1: 192.0.2.3
"Peer 1: 192.0.2.3: UPDATE
Peer 1: 192.0.2.3 - Received BGP UPDATE:
  Withdrawn Length = 0
  Total Path Attr Length = 86
  Flag: 0x90 Type: 14 Len: 23 Multiprotocol Reachable NLRI:
    Address Family MVPN_IPV4
    NextHop len 4 NextHop 192.0.2.3
    Type: Intra-AD Len: 12 RD: 64500:103 Orig: 192.0.2.3
  Flag: 0x40 Type: 1 Len: 1 Origin: 0
  Flag: 0x40 Type: 2 Len: 0 AS Path:
  Flag: 0x80 Type: 4 Len: 4 MED: 0
  Flag: 0x40 Type: 5 Len: 4 Local Preference: 100
  Flag: 0xc0 Type: 8 Len: 4 Community:
    no-export
  Flag: 0xc0 Type: 16 Len: 8 Extended Community:
    target:64500:1
  Flag: 0xc0 Type: 22 Len: 17 PMSI:
    Tunnel-type RSVP-TE P2MP LSP (1)
    Flags [Leaf not required]
    MPLS Label 0
    P2MP-ID 0x7919, Tunnel-ID: 62688, Extended-Tunnel-ID 192.0.2.3
"

109 2013/10/21 16:58:10.35 CEST MINOR: DEBUG #2001 Base Peer 1: 192.0.2.3
"Peer 1: 192.0.2.3: UPDATE
Peer 1: 192.0.2.3 - Send BGP UPDATE:
  Withdrawn Length = 0
  Total Path Attr Length = 86
  Flag: 0x90 Type: 14 Len: 23 Multiprotocol Reachable NLRI:
    Address Family MVPN_IPV4
    NextHop len 4 NextHop 192.0.2.1
    Type: Intra-AD Len: 12 RD: 64500:101 Orig: 192.0.2.1
  Flag: 0x40 Type: 1 Len: 1 Origin: 0
  Flag: 0x40 Type: 2 Len: 0 AS Path:
  Flag: 0x80 Type: 4 Len: 4 MED: 0
  Flag: 0x40 Type: 5 Len: 4 Local Preference: 100
  Flag: 0xc0 Type: 8 Len: 4 Community:
    no-export
  Flag: 0xc0 Type: 16 Len: 8 Extended Community:
    target:64500:1
  Flag: 0xc0 Type: 22 Len: 17 PMSI:
    Tunnel-type RSVP-TE P2MP LSP (1)
    Flags [Leaf not required]
    MPLS Label 0
    P2MP-ID 0x7919, Tunnel-ID: 62342, Extended-Tunnel-ID 192.0.2.1
"

116 2013/10/21 16:58:11.30 CEST MINOR: DEBUG #2001 Base Peer 1: 192.0.2.3
"Peer 1: 192.0.2.3: UPDATE
Peer 1: 192.0.2.3 - Send BGP UPDATE:
  Withdrawn Length = 0
  Total Path Attr Length = 69
  Flag: 0x90 Type: 14 Len: 33 Multiprotocol Reachable NLRI:
    Address Family MVPN_IPV4
    NextHop len 4 NextHop 192.0.2.1
    Type: Source-Join Len:22 RD: 64500:103 SrcAS: 64500 Src: 172.16.3.1
  Grp: 232.0.0.1
  Flag: 0x40 Type: 1 Len: 1 Origin: 0
```

Multicast VPN: Sender-Only, Receiver-Only

```
Flag: 0x40 Type: 2 Len: 0 AS Path:
Flag: 0x80 Type: 4 Len: 4 MED: 0
Flag: 0x40 Type: 5 Len: 4 Local Preference: 100
Flag: 0xc0 Type: 16 Len: 8 Extended Community:
    target:192.0.2.3:2086
"

120 2013/10/21 16:58:11.31 CEST MINOR: DEBUG #2001 Base Peer 1: 192.0.2.3
"Peer 1: 192.0.2.3: UPDATE
Peer 1: 192.0.2.3 - Received BGP UPDATE:
    Withdrawn Length = 0
    Total Path Attr Length = 65
    Flag: 0x90 Type: 14 Len: 29 Multiprotocol Reachable NLRI:
        Address Family MVPN_IPV4
        NextHop len 4 NextHop 192.0.2.3
        Type: Source-AD Len: 18 RD: 64500:103 Src: 172.16.3.1 Grp: 232.0.0.1
    Flag: 0x40 Type: 1 Len: 1 Origin: 0
    Flag: 0x40 Type: 2 Len: 0 AS Path:
    Flag: 0x80 Type: 4 Len: 4 MED: 0
    Flag: 0x40 Type: 5 Len: 4 Local Preference: 100
    Flag: 0xc0 Type: 16 Len: 8 Extended Community:
        target:64500:1
"
```

Similar behavior is observed for IPv6 multicast.

The BGP debug output below is taken from PE-1 and demonstrates the message flow between PE-1 and PE-3 for the MVPN-IPv6 address family.

Note: The PMSI part is present in debug message 108, which is sent by PE-3 (**sender-only**).

```
108 2013/10/21 16:58:09.43 CEST MINOR: DEBUG #2001 Base Peer 1: 192.0.2.3
"Peer 1: 192.0.2.3: UPDATE
Peer 1: 192.0.2.3 - Received BGP UPDATE:
    Withdrawn Length = 0
    Total Path Attr Length = 86
    Flag: 0x90 Type: 14 Len: 23 Multiprotocol Reachable NLRI:
        Address Family MVPN_IPV6
        NextHop len 4 NextHop 192.0.2.3
        Type: Intra-AD Len: 12 RD: 64500:103 Orig: 192.0.2.3
    Flag: 0x40 Type: 1 Len: 1 Origin: 0
    Flag: 0x40 Type: 2 Len: 0 AS Path:
    Flag: 0x80 Type: 4 Len: 4 MED: 0
    Flag: 0x40 Type: 5 Len: 4 Local Preference: 100
    Flag: 0xc0 Type: 8 Len: 4 Community:
        no-export
    Flag: 0xc0 Type: 16 Len: 8 Extended Community:
        target:64500:1
    Flag: 0xc0 Type: 22 Len: 17 PMSI:
        Tunnel-type RSVP-TE P2MP LSP (1)
        Flags [Leaf not required]
        MPLS Label 0
        P2MP-ID 0x7919, Tunnel-ID: 62688, Extended-Tunnel-ID 192.0.2.3
"
```

```
110 2013/10/21 16:58:10.34 CEST MINOR: DEBUG #2001 Base Peer 1: 192.0.2.3
"Peer 1: 192.0.2.3: UPDATE
```

RSVP-Based MVPN Configuration

```
Peer 1: 192.0.2.3 - Send BGP UPDATE:
  Withdrawn Length = 0
  Total Path Attr Length = 86
  Flag: 0x90 Type: 14 Len: 23 Multiprotocol Reachable NLRI:
    Address Family MVPN_IPV6
    NextHop len 4 NextHop 192.0.2.1
      Type: Intra-AD Len: 12 RD: 64500:101 Orig: 192.0.2.1
  Flag: 0x40 Type: 1 Len: 1 Origin: 0
  Flag: 0x40 Type: 2 Len: 0 AS Path:
  Flag: 0x80 Type: 4 Len: 4 MED: 0
  Flag: 0x40 Type: 5 Len: 4 Local Preference: 100
  Flag: 0xc0 Type: 8 Len: 4 Community:
    no-export
  Flag: 0xc0 Type: 16 Len: 8 Extended Community:
    target:64500:1
  Flag: 0xc0 Type: 22 Len: 17 PMSI:
    Tunnel-type RSVP-TE P2MP LSP (1)
    Flags [Leaf not required]
    MPLS Label 0
    P2MP-ID 0x7919, Tunnel-ID: 62342, Extended-Tunnel-ID 192.0.2.1
"

118 2013/10/21 16:58:11.31 CEST MINOR: DEBUG #2001 Base Peer 1: 192.0.2.3
"Peer 1: 192.0.2.3: UPDATE
Peer 1: 192.0.2.3 - Send BGP UPDATE:
  Withdrawn Length = 0
  Total Path Attr Length = 93
  Flag: 0x90 Type: 14 Len: 57 Multiprotocol Reachable NLRI:
    Address Family MVPN_IPV6
    NextHop len 4 NextHop 192.0.2.1
      Type: Source-Join Len: 46 RD: 64500:103 SrcAS: 64500 Src: 2001:DB8:3
::1 Grp: FF3E::8000:1
  Flag: 0x40 Type: 1 Len: 1 Origin: 0
  Flag: 0x40 Type: 2 Len: 0 AS Path:
  Flag: 0x80 Type: 4 Len: 4 MED: 0
  Flag: 0x40 Type: 5 Len: 4 Local Preference: 100
  Flag: 0xc0 Type: 16 Len: 8 Extended Community:
    target:192.0.2.3:2086
"

121 2013/10/21 16:58:11.31 CEST MINOR: DEBUG #2001 Base Peer 1: 192.0.2.3
"Peer 1: 192.0.2.3: UPDATE
Peer 1: 192.0.2.3 - Received BGP UPDATE:
  Withdrawn Length = 0
  Total Path Attr Length = 89
  Flag: 0x90 Type: 14 Len: 53 Multiprotocol Reachable NLRI:
    Address Family MVPN_IPV6
    NextHop len 4 NextHop 192.0.2.3
      Type: Source-AD Len: 42 RD: 64500:103 Src: 2001:DB8:3::1 Grp: FF3E
::8000:1
  Flag: 0x40 Type: 1 Len: 1 Origin: 0
  Flag: 0x40 Type: 2 Len: 0 AS Path:
  Flag: 0x80 Type: 4 Len: 4 MED: 0
  Flag: 0x40 Type: 5 Len: 4 Local Preference: 100
  Flag: 0xc0 Type: 16 Len: 8 Extended Community:
    target:64500:1
"
```

The BGP routing table of each router is populated accordingly.

PE-1 (**sender-receiver**) has two Intra-Ad messages from PE-2 and PE-3 and one Source-Ad from PE-3.

```
*A:PE-1# show router bgp routes mvpn-ipv4
=====
BGP Router ID:192.0.2.1      AS:64500      Local AS:64500
=====
Legend -
Status codes  : u - used, s - suppressed, h - history, d - decayed, * - valid
Origin codes  : i - IGP, e - EGP, ? - incomplete, > - best, b - backup

=====
BGP MVPN-IPv4 Routes
=====
Flag  RouteType      OriginatorIP      LocalPref  MED
      RD           SourceAS          Label
      Nexthop      SourceIP
      As-Path      GroupIP
-----
u*>i  Intra-Ad         192.0.2.2        100        0
      64500:102     -                -
      192.0.2.2    -
      No As-Path   -
u*>i  Intra-Ad         192.0.2.3        100        0
      64500:103     -                -
      192.0.2.3    -
      No As-Path   -
u*>i  Source-Ad        -                100        0
      64500:103     -                -
      192.0.2.3    172.16.3.1
      No As-Path   232.0.0.1
-----
Routes : 3
=====
```

PE-2 (**receiver-only**) has two Intra-Ad messages from PE-1 and PE-3 and one Source-Ad from PE-3.

```
*A:PE-2# show router bgp routes mvpn-ipv4
=====
BGP Router ID:192.0.2.2      AS:64500      Local AS:64500
=====
Legend -
Status codes  : u - used, s - suppressed, h - history, d - decayed, * - valid
Origin codes  : i - IGP, e - EGP, ? - incomplete, > - best, b - backup

=====
BGP MVPN-IPv4 Routes
=====
Flag  RouteType      OriginatorIP      LocalPref  MED
      RD           SourceAS          Label
      Nexthop      SourceIP
      As-Path      GroupIP
-----
```

RSVP-Based MVPN Configuration

```

u*>i Intra-Ad          192.0.2.1          100          0
      64500:101        -                -            -
      192.0.2.1        -                -            -
      No As-Path       -                -            -
u*>i Intra-Ad          192.0.2.3          100          0
      64500:103        -                -            -
      192.0.2.3        -                -            -
      No As-Path       -                -            -
u*>i Source-Ad         -                100          0
      64500:103        -                -            -
      192.0.2.3        172.16.3.1      -            -
      No As-Path       232.0.0.1        -            -

```

```

-----
Routes : 3
=====

```

PE-3 (**sender-only**) has two Intra-Ad and two Source-Join messages from PE-1 and PE-2.

```

*A:PE-3# show router bgp routes mvpn-ipv4

```

```

=====
BGP Router ID:192.0.2.3      AS:64500      Local AS:64500
=====

```

Legend -

Status codes : u - used, s - suppressed, h - history, d - decayed, * - valid

Origin codes : i - IGP, e - EGP, ? - incomplete, > - best, b - backup

```

=====
BGP MVPN-IPv4 Routes
=====

```

Flag	RouteType	OriginatorIP	LocalPref	MED
	RD	SourceAS		Label
	NextHop	SourceIP		
	As-Path	GroupIP		
u*>i	Intra-Ad	192.0.2.1	100	0
	64500:101	-		-
	192.0.2.1	-		-
	No As-Path	-		-
u*>i	Intra-Ad	192.0.2.2	100	0
	64500:102	-		-
	192.0.2.2	-		-
	No As-Path	-		-
u*>i	Source-Join	-	100	0
	64500:103	64500		-
	192.0.2.1	172.16.3.1		-
	No As-Path	232.0.0.1		-
*>i	Source-Join	-	100	0
	64500:103	64500		-
	192.0.2.2	172.16.3.1		-
	No As-Path	232.0.0.1		-

```

-----
Routes : 4
=====

```

RSVP Verification and Debugging

When BGP intra-AD messages are exchanged every PE starts to build multicast tunnels based on the following criteria:

- PE nodes which are configured as **sender-only** for a given MVPN do not join P2MP LSPs from other PEs in this MVPN.
- PE nodes which are configured as receiver-only for a given MVPN do not originate P2MP LSPs to other PEs in this MVPN.

The RSVP session can be checked with the **show>router>rsvp>session** command:

PE-1 (192.0.2.1) has two originating LSPs towards PE-2 (192.0.2.2) and PE-3 (192.0.2.3) and one incoming LSP from PE-3 (**mdt-type sender-only**).

```
*A:PE-1#show router rsvp session
=====
RSVP Sessions
=====
From          To            Tunnel LSP   Name                               State
              ID           ID
-----
192.0.2.1     192.0.2.2     62342  52224  mvpn-p2mp-lsp-1-73741:* Up
192.0.2.1     192.0.2.3     62342  52224  mvpn-p2mp-lsp-1-73741:* Up
192.0.2.3     192.0.2.1     62688  39424  mvpn-p2mp-lsp-1-73741:* Up
```

PE-2 (192.0.2.2) has two incoming LSPs from PE-1 (192.0.2.1) and PE-3 (192.0.2.3) and no originating LSPs due to the fact that PE-2 has **mdt-type receiver-only**.

```
*A:PE-2#show router rsvp session
=====
RSVP Sessions
=====
From          To            Tunnel LSP   Name                               State
              ID           ID
-----
192.0.2.1     192.0.2.2     62342  52224  mvpn-p2mp-lsp-1-73741:* Up
192.0.2.3     192.0.2.2     62688  39424  mvpn-p2mp-lsp-1-73741:* Up
```

PE-3 (192.0.2.3) has two originating LSPs towards PE-2 (192.0.2.2) and PE-1 (192.0.2.1) and one incoming LSP from PE-1 (**mdt-type sender-receiver**).

Theoretically there is no need for the LSP from PE-1 towards PE-3 as PE-3 is a sender-only; this minor limitation should be taken into account during planning phase.

```
*A:PE-3#show router rsvp session
=====
RSVP Sessions
=====
From          To            Tunnel LSP   Name                               State
              ID           ID
-----
```

RSVP-Based MVPN Configuration

```

                                     ID      ID
-----
192.0.2.1      192.0.2.3      62342  52224  mvpn-p2mp-lsp-1-73741::* Up
192.0.2.3      192.0.2.1      62688  39424  mvpn-p2mp-lsp-1-73741::* Up
192.0.2.3      192.0.2.2      62688  39424  mvpn-p2mp-lsp-1-73741::* Up

```

Additional details about originating P2MP paths can be found using the following command:

show>router>mpls p2mp-lsp <lsp name> p2mp-instance <service number> s2l

PE-1 output:

```

*A:PE-1# show router mpls p2mp-lsp "mvpn-p2mp-lsp-1-73741" p2mp-instance "1" s2l
=====
MPLS LSP mvpn-p2mp-lsp-1-73741 S2L
=====
-----
LSP Name       : mvpn-p2mp-lsp-1-73741          P2MP ID       : 1
Adm State      : Up                            Oper State    : Up
P2MPInstance: 1                               Inst-type     : Primary
Adm State      : Up                            Oper State    : PartialInService
-----
S2l Name              To                Next Hop        Adm  Opr
-----
mvpn-p2mp-path        192.0.2.2         192.168.12.1   Up   Up
mvpn-p2mp-path        192.0.2.3         192.168.13.1   Up   Up

```

PE-2 output:

```

*A:PE-2# show router mpls p2mp-lsp
=====
MPLS P2MP LSPs (Originating)
=====
-----
LSP Name              Tun      Fastfail  Adm  Opr
                       Id        Config
-----
No Matching Entries Found
=====

```

PE-3 output:

```

A:PE-# show router mpls p2mp-lsp "mvpn-p2mp-lsp-1-73741" p2mp-instance "1" s2l
=====
MPLS LSP mvpn-p2mp-lsp-1-73741 S2L
=====
-----
LSP Name       : mvpn-p2mp-lsp-1-73741          P2MP ID       : 1
Adm State      : Up                            Oper State    : Up
P2MPInstance: 1                               Inst-type     : Primary
Adm State      : Up                            Oper State    : PartialInService
-----
S2l Name              To                Next Hop        Adm  Opr
-----
mvpn-p2mp-path        192.0.2.1         192.168.13.0   Up   Up
mvpn-p2mp-path        192.0.2.2         192.168.23.0   Up   Up

```

Multicast Stream Verification

The status of the multicast groups/streams can be verified using **show>router <sid>>pim group detail ipv6** command:

There is an IPv4 receiver connected to PE-1. An I-PMSI is used as the incoming interface and the physical interface where the receiver is connected is used as the outgoing interface.

```
A:PE-1#show router 1 pim group detail
=====
PIM Source Group ipv4
=====
Group Address       : 232.0.0.1
Source Address      : 172.16.3.1
RP Address          : 0
Advt Router         : 192.0.2.3
Flags               :                               Type           : (S,G)
MRIB Next Hop      : 192.0.2.3
<snip>
Rpf Neighbor       : 192.0.2.3
Incoming Intf      : mpls-if-73743
Outgoing Intf List : int-mcast-receiver

Curr Fwding Rate   : 85636.0 kbps
<snip>
```

There is an IPv4 receiver connected to PE-2. An I-PMSI is used as the incoming interface and the physical interface where the receiver is connected is used as the outgoing interface.

```
A:PE-2# show router 1 pim group detail
```

```
=====
PIM Source Group ipv4
=====
Group Address       : 232.0.0.1
Source Address      : 172.16.3.1
RP Address          : 0
Advt Router         : 192.0.2.3
Flags               :                               Type           : (S,G)
MRIB Next Hop      : 192.0.2.3
<snip>
Rpf Neighbor       : 192.0.2.3
Incoming Intf      : mpls-if-73753
Outgoing Intf List : int-mcast-receiver

Curr Fwding Rate   : 85624.6 kbps
<snip>
```

There is an IPv4 sender connected to PE-3. An I-PMSI is used as the outgoing interface and the physical interface where sender is connected is used as the incoming interface.

```
A:PE-3#show router 1 pim group detail
```

RSVP-Based MVPN Configuration

```
=====
PIM Source Group ipv4
=====
Group Address      : 232.0.0.1
Source Address     : 172.16.3.1
RP Address         : 0
Advt Router        : 192.0.2.3
Flags              :                               Type           : (S,G)
MRIB Next Hop     : 172.16.3.1
<snip>
Rpf Neighbor       : 172.16.3.1
Incoming Intf     : int-mcast-source
Outgoing Intf List : mpls-if-73741

Curr Fwding Rate   : 85625.0 kbps
<snip>
```

Similar behavior is observed for IPv6 multicast.

There is an IPv6 receiver connected to PE-1. An I-PMSI is used as the incoming interface and the physical interface where the receiver is connected is used as the outgoing interface.

```
A:PE-1#show router 1 pim group detail ipv6
=====
PIM Source Group ipv6
=====
Group Address      : FF3E::8000:1
Source Address     : 2001:DB8:3::1
RP Address         : 0
Advt Router        : 192.0.2.3
Flags              :                               Type           : (S,G)
MRIB Next Hop     : 192.0.2.3
<snip>
Rpf Neighbor       : 192.0.2.3
Incoming Intf     : mpls-if-73743
Outgoing Intf List : int-mcast-receiver

Curr Fwding Rate   : 2140.5 kbps
<snip>
```

There is an IPv6 receiver connected to PE-2. An I-PMSI is used as the incoming interface and the physical interface where the receiver is connected is used as the outgoing interface.

```
A:PE-2# show router 1 pim group detail ipv6
=====
PIM Source Group ipv6
=====
Group Address      : FF3E::8000:1
Source Address     : 2001:DB8:3::1
RP Address         : 0
Advt Router        : 192.0.2.3
Flags              :                               Type           : (S,G)
MRIB Next Hop     : 192.0.2.3
<snip>
Rpf Neighbor       : 192.0.2.3
```

Multicast VPN: Sender-Only, Receiver-Only

```
Incoming Intf      : mpls-if-73753
Outgoing Intf List : int-mcast-receiver

Curr Fwding Rate   : 2139.4 kbps
<snip>
```

There is an IPv6 sender connected to PE-3. An I-PMSI is used as the outgoing interface and the physical interface where the sender is connected is used as the incoming interface.

```
A:PE-3# show router 1 pim group detail ipv6
=====
PIM Source Group ipv6
=====
Group Address      : FF3E::8000:1
Source Address     : 2001:DB8:3::1
RP Address         : 0
Advt Router        : 192.0.2.3
Flags              :
Type               : (S,G)
MRIB Next Hop     : 2001:DB8:3::1
<snip>
Rpf Neighbor       : 2001:DB8:3::1
Incoming Intf      : int-mcast-source
Outgoing Intf List : mpls-if-73741

Curr Fwding Rate   : 2140.5 kbps
<snip>
```

mLDP-Based MVPN Configuration

Step 0: Configure a basic MVPN using mLDP as a transport protocol for C-multicast groups. PE-1 and PE-2 have static joins for the IPv4/IPv6 multicast groups:

- group 232.0.0.1, source 172.16.3.1
- group FF3E::8000:1, source 2001:DB8:3::1

Step 1. Configure the MDT type for the MVPN.

Based on the test topology PE-3 is configured as sender-only for MVPN:

```
*A:PE-3>config>service>vprn# info
-----
description "mLDP based MVPN"
<snip>
interface "int-mcast-source" create
  description "10G STC port 12/2"
  address 172.16.3.2/30
  ipv6
    address 2001:DB8:3::2/126
  exit
  sap 3/1/10:3.1002 create
  exit
exit
pim
  no ipv6-multicast-disable
  apply-to all
  rp
    static
    exit
    bsr-candidate
    shutdown
    exit
    rp-candidate
    shutdown
    exit
  exit
  no shutdown
exit
mvpn
  auto-discovery default
  c-mcast-signaling bgp
  mdt-type sender-only
  provider-tunnel
    inclusive
    mldp
    no shutdown
  exit
  exit
exit
vrf-target unicast
exit
```

```

exit
service-name "mLDP based MVPN"
spoke-sdp 10132 create
exit
no shutdown
<snip>

```

Based on the test topology, PE-2 is configured as receiver-only for the MVPN. PE-2 has also static joins for the IPv4 and IPv6 multicast groups:

- group 232.0.0.1,source 172.16.3.1
- group FF3E::8000:1, source 2001:DB8:3::1

```

*A:PE-2>config>service>vprn# info
-----
description "mLDP based MVPN"
<snip>
interface "int-mcast-receiver" create
description "10G STC port 10/2"
address 172.16.2.2/30
ipv6
address 2001:DB8:2::2/126
exit
sap 2/2/1:3.1002 create
exit
exit
igmp
interface "int-mcast-receiver"
static
group 232.0.0.1
source 172.16.3.1
exit
exit
no shutdown
exit
no shutdown
exit
mld
interface "int-mcast-receiver"
static
group FF3E::8000:1
source 2001:DB8:3::1
exit
exit
no shutdown
exit
no shutdown
exit
pim
no ipv6-multicast-disable
apply-to all
rp
static
exit
bsr-candidate
shutdown

```

mLDP-Based MVPN Configuration

```
        exit
        rp-candidate
        shutdown
    exit
    exit
    no shutdown
exit
mvpn
    auto-discovery default
    c-mcast-signaling bgp
    mdt-type receiver-only
    provider-tunnel
        inclusive
        mldp
            no shutdown
        exit
    exit
    exit
    vrf-target unicast
    exit
exit
service-name "mLDP based MVPN"
<snip>
```

Based on the test topology, PE-1 is configured as **sender-receiver** (default) for the MVPN. PE-1 has also static joins for the IPv4 and IPv6 multicast groups:

- group 232.0.0.1, source 172.16.3.1
- group FF3E::8000:1, source 2001:DB8:3::1

```
*A:PE-1>config>service>vprn# info
-----
description "mLDP based MVPN"
<snip>
interface "int-mcast-receiver" create
    description "10G STC port 10/1"
    address 172.16.1.2/30
    ipv6
        address 2001:DB8:1::2/126
    exit
    sap 2/1/1:3.1002 create
    exit
exit
igmp
    interface "int-mcast-receiver"
        static
            group 232.0.0.1
            source 172.16.3.1
        exit
    exit
    no shutdown
exit
no shutdown
exit
mld
    interface "int-mcast-receiver"
```

Multicast VPN: Sender-Only, Receiver-Only

```
static
  group FF3E::8000:1
  source 2001:DB8:3::1
  exit
exit
no shutdown
exit
no shutdown
exit
pim
no ipv6-multicast-disable
apply-to all
rp
  static
  exit
  bsr-candidate
  shutdown
  exit
  rp-candidate
  shutdown
  exit
  exit
no shutdown
exit
mvpn
  auto-discovery default
  c-mcast-signaling bgp
  provider-tunnel
  inclusive
  mldp
  no shutdown
  exit
  exit
  vrf-target unicast
  exit
exit
service-name "mLDP based MVPN"
```

Note: The PIM instance must be **shutdown** before the mdt-type is modified; this leads to multicast service disruption. Trying to change mdt-type with the PIM instance active will result in the message below being displayed.

```
*A:PE-1>config>service>vprn>mvpn# mdt-type sender-only
MINOR: PIM #1100 PIM instance must be shutdown before changing this configuration
```

mLDP-Based MVPN Verification and Debugging

MDT-Type Verification

The status of the MVPN can be checked using the following command:

```
show router <service-number> mvpn
```

PE-1 output:

```
*A:PE-1# show router 2 mvpn
=====
MVPN 2 configuration data
=====
signaling          : Bgp                auto-discovery    : Default
UMH Selection      : Highest-Ip          intersite-shared  : Enabled
vrf-import         : N/A
vrf-export         : N/A
vrf-target         : unicast
C-Mcast Import RT : target:192.0.2.1:2

ipmsi              : ldp
i-pmsi P2MP AdmSt  : Up
i-pmsi Tunnel Name : mpls-if-73734
Mdt-type           : sender-receiver

s-pmsi             : none
data-delay-interval: 3 seconds
enable-asm-mdt     : N/A
=====
```

PE-2 output:

```
A:PE-2# show router 2 mvpn
=====
MVPN 2 configuration data
=====
signaling          : Bgp                auto-discovery    : Default
UMH Selection      : Highest-Ip          intersite-shared  : Enabled
vrf-import         : N/A
vrf-export         : N/A
vrf-target         : unicast
C-Mcast Import RT : target:192.0.2.2:1906

ipmsi              : ldp
i-pmsi P2MP AdmSt  : Up
i-pmsi Tunnel Name : mpls-virt-if-640321
Mdt-type           : receiver-only

s-pmsi             : none
data-delay-interval: 3 seconds
enable-asm-mdt     : N/A
=====
```

PE-3 output:

```
*A:PE-3# show router 2 mvpn
=====
MVPN 2 configuration data
=====
signaling          : Bgp                auto-discovery    : Default
UMH Selection      : Highest-IP         intersite-shared   : Enabled
vrf-import         : N/A
vrf-export         : N/A
vrf-target         : unicast
C-Mcast Import RT : target:192.0.2.3:2087

ipmsi              : ldp
i-pmsi P2MP AdmSt  : Up
i-pmsi Tunnel Name : mpls-if-73752
Mdt-type           : sender-only

s-pmsi             : none
data-delay-interval: 3 seconds
enable-asm-mdt     : N/A
=====
```

BGP Verification and Debugging

When the MDT type is changed the BGP signaling is slightly modified in order to achieve the signaling optimization. The PE router does not include the PMSI part in Intra-AD BGP messages when the MVPN is configured with mdt-type as **receiver-only**.

The message flow is presented in [Figure 105](#).

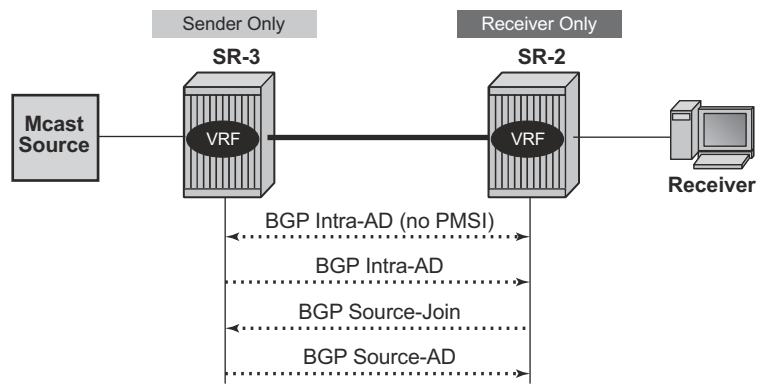

al_0332

Figure 105: mLDP-Based BGP Message Flow Between PE-2 and PE-3

In order to demonstrate the BGP message flow sequence the following initialization steps are taken:

0. Bring down the VPRN service, PIM protocol in a VPRN and IGMP/MLD protocol. As a result the state of all signaling protocols is cleared.
1. Bring up the VPRN service. BGP exchanges unicast routing information.
2. Bring up the IPv4 PIM protocol. BGP exchanges IPv4 multicast routing information in order to build the PMSI infrastructure.
3. Bring up IGMP and add a static IGMP join where it is applicable. BGP exchanges IPv4 multicast routing information in order to propagate the multicast traffic to the receiver.
4. Bring up the IPv6 PIM protocol. BGP exchanges IPv6 multicast routing information in order to build the PMSI infrastructure.
5. Bring up MLD and add a static MLD join where it is applicable. BGP exchanges IPv6 multicast routing information in order to propagate the multicast traffic to the receiver.

The BGP debug below is taken from PE-2 and demonstrates the message flow between PE-2 and PE-3. VPN-IPv4 and VPN-IPv6 updates are not present in this output.

Step 0: Bring down service and protocols to clear the state of all signalling protocols.

```
*A:PE-2>config>service>vprn# shutdown
*A:PE-2>config>service>vprn# pim shutdown
*A:PE-2>config>service>vprn# igmp shutdown
*A:PE-2>config>service>vprn# mld shutdown
*A:PE-2>config>service>vprn# pim ipv6-multicast-disable
```

Step 1. Enable the VPRN service on PE-2. PE-2 immediately receives Intra-AD messages from PE-3 because the remote VPRN service is already enabled for IPv4 and IPv6 multicast propagation.

```
*A:PE-2>config>service>vprn# no shutdown
*A:PE-2>config>service>vprn#

4099 2013/10/25 13:43:04.45 CEST MINOR: DEBUG #2001 Base Peer 1: 192.0.2.3
"Peer 1: 192.0.2.3: UPDATE
Peer 1: 192.0.2.3 - Received BGP UPDATE:
  Withdrawn Length = 0
  Total Path Attr Length = 91
  Flag: 0x90 Type: 14 Len: 23 Multiprotocol Reachable NLRI:
    Address Family MVPN_IPV4
    NextHop len 4 NextHop 192.0.2.3
    Type: Intra-AD Len: 12 RD: 64500:203 Orig: 192.0.2.3
  Flag: 0x40 Type: 1 Len: 1 Origin: 0
  Flag: 0x40 Type: 2 Len: 0 AS Path:
  Flag: 0x80 Type: 4 Len: 4 MED: 0
  Flag: 0x40 Type: 5 Len: 4 Local Preference: 100
  Flag: 0xc0 Type: 8 Len: 4 Community:
    no-export
  Flag: 0xc0 Type: 16 Len: 8 Extended Community:
```

```

target:64500:2
Flag: 0xc0 Type: 22 Len: 22 PMSI:
Tunnel-type LDP P2MP LSP (2)
Flags [Leaf not required]
MPLS Label 0
Root-Node 192.0.2.3, LSP-ID 0x2001
"

4100 2013/10/25 13:43:04.46 CEST MINOR: DEBUG #2001 Base Peer 1: 192.0.2.3
"Peer 1: 192.0.2.3: UPDATE
Peer 1: 192.0.2.3 - Received BGP UPDATE:
Withdrawn Length = 0
Total Path Attr Length = 91
Flag: 0x90 Type: 14 Len: 23 Multiprotocol Reachable NLRI:
Address Family MVPN_IPV6
NextHop len 4 NextHop 192.0.2.3
Type: Intra-AD Len: 12 RD: 64500:203 Orig: 192.0.2.3
Flag: 0x40 Type: 1 Len: 1 Origin: 0
Flag: 0x40 Type: 2 Len: 0 AS Path:
Flag: 0x80 Type: 4 Len: 4 MED: 0
Flag: 0x40 Type: 5 Len: 4 Local Preference: 100
Flag: 0xc0 Type: 8 Len: 4 Community:
no-export
Flag: 0xc0 Type: 16 Len: 8 Extended Community:
target:64500:2
Flag: 0xc0 Type: 22 Len: 22 PMSI:
Tunnel-type LDP P2MP LSP (2)
Flags [Leaf not required]
MPLS Label 0
Root-Node 192.0.2.3, LSP-ID 0x2001
"

```

Step 2. Enable only PIM IPv4 for the service on PE-2. PE-2 immediately sends Intra-AD messages to PE-3. Note: there is no PMSI part present in debug message 4101.

```

*A:PE-2>config>service>vprn# pim no shutdown
*A:PE-2>config>service>vprn#
4101 2013/10/25 13:43:16.34 CEST MINOR: DEBUG #2001 Base Peer 1: 192.0.2.3
"Peer 1: 192.0.2.3: UPDATE
Peer 1: 192.0.2.3 - Send BGP UPDATE:
Withdrawn Length = 0
Total Path Attr Length = 66
Flag: 0x90 Type: 14 Len: 23 Multiprotocol Reachable NLRI:
Address Family MVPN_IPV4
NextHop len 4 NextHop 192.0.2.2
Type: Intra-AD Len: 12 RD: 64500:202 Orig: 192.0.2.2
Flag: 0x40 Type: 1 Len: 1 Origin: 0
Flag: 0x40 Type: 2 Len: 0 AS Path:
Flag: 0x80 Type: 4 Len: 4 MED: 0
Flag: 0x40 Type: 5 Len: 4 Local Preference: 100
Flag: 0xc0 Type: 8 Len: 4 Community:
no-export
Flag: 0xc0 Type: 16 Len: 8 Extended Community:
target:64500:2
"

```

Step 3. Bring up IGMP and add a static IGMP join for the service on a PE-2. PE-2 immediately sends a source-join message to PE-3 and receives a source-AD message from PE-3.

```
*A:PE-2>config>service>vprn# igmp shutdown
*A:PE-2>config>service>vprn# igmp interface "int-mcast-receiver" static group 232.0.0.1
source 172.16.3.1
```

```
*A:PE-2>config>service>vprn#
4102 2013/10/25 13:43:25.36 CEST MINOR: DEBUG #2001 Base Peer 1: 192.0.2.3
"Peer 1: 192.0.2.3: UPDATE
Peer 1: 192.0.2.3 - Send BGP UPDATE:
  Withdrawn Length = 0
  Total Path Attr Length = 69
  Flag: 0x90 Type: 14 Len: 33 Multiprotocol Reachable NLRI:
    Address Family MVPN_IPV4
    NextHop len 4 NextHop 192.0.2.2
    Type: Source-Join Len:22 RD: 64500:203 SrcAS: 64500 Src: 172.16.3.1
  Grp: 232.0.0.1
    Flag: 0x40 Type: 1 Len: 1 Origin: 0
    Flag: 0x40 Type: 2 Len: 0 AS Path:
    Flag: 0x80 Type: 4 Len: 4 MED: 0
    Flag: 0x40 Type: 5 Len: 4 Local Preference: 100
    Flag: 0xc0 Type: 16 Len: 8 Extended Community:
      target:192.0.2.3:2087
"
```

```
4103 2013/10/25 13:43:25.36 CEST MINOR: DEBUG #2001 Base Peer 1: 192.0.2.3
"Peer 1: 192.0.2.3: UPDATE
Peer 1: 192.0.2.3 - Received BGP UPDATE:
  Withdrawn Length = 0
  Total Path Attr Length = 65
  Flag: 0x90 Type: 14 Len: 29 Multiprotocol Reachable NLRI:
    Address Family MVPN_IPV4
    NextHop len 4 NextHop 192.0.2.3
    Type: Source-AD Len: 18 RD: 64500:203 Src: 172.16.3.1 Grp: 232.0.0.1
  Flag: 0x40 Type: 1 Len: 1 Origin: 0
  Flag: 0x40 Type: 2 Len: 0 AS Path:
  Flag: 0x80 Type: 4 Len: 4 MED: 0
  Flag: 0x40 Type: 5 Len: 4 Local Preference: 100
  Flag: 0xc0 Type: 16 Len: 8 Extended Community:
    target:64500:2
"
```

Step 4. Enable PIM IPv6 for the service on PE-2. PE-2 immediately sends Intra-AD messages to PE-3.

```
*A:PE-2>config>service>vprn# pim no ipv6-multicast-disable
*A:PE-2>config>service>vprn#
4104 2013/10/25 13:43:47.36 CEST MINOR: DEBUG #2001 Base Peer 1: 192.0.2.3
"Peer 1: 192.0.2.3: UPDATE
Peer 1: 192.0.2.3 - Send BGP UPDATE:
  Withdrawn Length = 0
  Total Path Attr Length = 66
  Flag: 0x90 Type: 14 Len: 23 Multiprotocol Reachable NLRI:
    Address Family MVPN_IPV6
    NextHop len 4 NextHop 192.0.2.2
    Type: Intra-AD Len: 12 RD: 64500:202 Orig: 32.1.13.184
"
```

```

Flag: 0x40 Type: 1 Len: 1 Origin: 0
Flag: 0x40 Type: 2 Len: 0 AS Path:
Flag: 0x80 Type: 4 Len: 4 MED: 0
Flag: 0x40 Type: 5 Len: 4 Local Preference: 100
Flag: 0xc0 Type: 8 Len: 4 Community:
    no-export
Flag: 0xc0 Type: 16 Len: 8 Extended Community:
    target:64500:2
"

```

Step 5. Bring up MLD and add a static MLD join for the service on a PE-2. PE-2 immediately sends a source-join message to PE-3 and receives a source-AD message from PE-3.

```

*A:PE-2>config>service>vprn# mld shutdown
*A:PE-2>config>service>vprn# mld interface "int-mcast-receiver" static group FF3E::8000:1
source 2001:DB8:3::1

```

```

*A:PE-2>config>service>vprn#
4105 2013/10/25 13:43:54.36 CEST MINOR: DEBUG #2001 Base Peer 1: 192.0.2.3
"Peer 1: 192.0.2.3: UPDATE
Peer 1: 192.0.2.3 - Send BGP UPDATE:
    Withdrawn Length = 0
    Total Path Attr Length = 93
    Flag: 0x90 Type: 14 Len: 57 Multiprotocol Reachable NLRI:
        Address Family MVPN_IPV6
        NextHop len 4 NextHop 192.0.2.2
        Type: Source-Join Len: 46 RD: 64500:203 SrcAS: 64500 Src: 2001:DB8:3
::1 Grp: FF3E::8000:1
    Flag: 0x40 Type: 1 Len: 1 Origin: 0
    Flag: 0x40 Type: 2 Len: 0 AS Path:
    Flag: 0x80 Type: 4 Len: 4 MED: 0
    Flag: 0x40 Type: 5 Len: 4 Local Preference: 100
    Flag: 0xc0 Type: 16 Len: 8 Extended Community:
        target:192.0.2.3:2087
"

```

```

4106 2013/10/25 13:43:54.36 CEST MINOR: DEBUG #2001 Base Peer 1: 192.0.2.3
"Peer 1: 192.0.2.3: UPDATE
Peer 1: 192.0.2.3 - Received BGP UPDATE:
    Withdrawn Length = 0
    Total Path Attr Length = 89
    Flag: 0x90 Type: 14 Len: 53 Multiprotocol Reachable NLRI:
        Address Family MVPN_IPV6
        NextHop len 4 NextHop 192.0.2.3
        Type: Source-AD Len: 42 RD: 64500:203 Src: 2001:DB8:3::1 Grp: FF3E
::8000:1
    Flag: 0x40 Type: 1 Len: 1 Origin: 0
    Flag: 0x40 Type: 2 Len: 0 AS Path:
    Flag: 0x80 Type: 4 Len: 4 MED: 0
    Flag: 0x40 Type: 5 Len: 4 Local Preference: 100
    Flag: 0xc0 Type: 16 Len: 8 Extended Community:
        target:64500:2

```

The same information can be gathered using the following show commands.

show>router>bgp>neighbor <peer> advertised-routes [mvpn-ipv4|mvpn-ipv6]

show>router>bgp>neighbor <peer> received-routes [mvpn-ipv4|mvpn-ipv6]

PE-2 output for the advertised routes for the mvpn-ipv4 address family.

```
*A:PE-2# show router bgp neighbor 192.0.2.3 advertised-routes mvpn-ipv4
=====
BGP MVPN-IPv4 Routes
=====
Flag  RouteType          OriginatorIP      LocalPref  MED
      RD              SourceAS          Label
      Nexthop         SourceIP
      As-Path         GroupIP
-----
i     Intra-Ad           192.0.2.2        100        0
      64500:202        -                -
      192.0.2.2        -
      No As-Path      -
i     Source-Join       -                100        0
      64500:203        64500            -
      192.0.2.2        172.16.3.1
      No As-Path      232.0.0.1
-----
Routes : 2
=====
```

PE-2 output for the advertised routers for the mvpn-ipv6 address family.

```
*A:PE-2# show router bgp neighbor 192.0.2.3 advertised-routes mvpn-ipv6
=====
BGP MVPN-IPv6 Routes
=====
Flag  RouteType          OriginatorIP      LocalPref  MED
      RD              SourceAS          Label
      Nexthop         SourceIP
      As-Path         GroupIP
-----
i     Intra-Ad           32.1.13.184     100        0
      64500:202        -                -
      192.0.2.2        -
      No As-Path      -
i     Source-Join       -                100        0
      64500:203        64500            -
      192.0.2.2        2001:DB8:3::1
      No As-Path      FF3E::8000:1
-----
Routes : 2
=====
```

PE-2 output for the received routes for the mvpn-ipv4 address family.

```
*A:PE-2# show router bgp neighbor 192.0.2.3 received-routes mvpn-ipv4
=====
BGP MVPN-IPv4 Routes
=====
```

Flag	RouteType	OriginatorIP	LocalPref	MED
	RD	SourceAS		Label
	Nexthop	SourceIP		
	As-Path	GroupIP		
u*>i	Intra-Ad	192.0.2.3	100	0
	64500:203	-		-
	192.0.2.3	-		
	No As-Path	-		
u*>i	Source-Ad	-	100	0
	64500:203	-		-
	192.0.2.3	172.16.3.1		
	No As-Path	232.0.0.1		

```
-----
Routes : 2
=====
```

PE-2 output for the received routes for the mvpn-ipv6 address family.

```
*A:PE-2# show router bgp neighbor 192.0.2.3 received-routes mvpn-ipv6
=====
BGP MVPN-IPv6 Routes
=====
```

Flag	RouteType	OriginatorIP	LocalPref	MED
	RD	SourceAS		Label
	Nexthop	SourceIP		
	As-Path	GroupIP		
u*>i	Intra-Ad	192.0.2.3	100	0
	64500:203	-		-
	192.0.2.3	-		
	No As-Path	-		
u*>i	Source-Ad	-	100	0
	64500:203	-		-
	192.0.2.3	2001:DB8:3::1		
	No As-Path	FF3E::8000:1		

```
-----
Routes : 2
=====
```

The PE router does not change the BGP behavior when the MVPN is configured with mdt-type as **sender-only**. A schematic of the message flow is presented in [Figure 106](#).

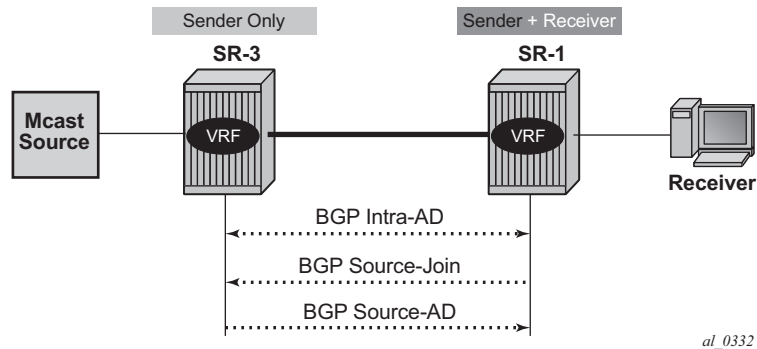

Figure 106: mLDP-Based BGP Message Flow Between PE-1 and PE-3

In order to demonstrate the BGP message flow sequence the following initialization steps are taken:

0. Bring down VPRN service, PIM protocol in a VPRN and IGMP/MLD protocol. As a result the state of all signaling protocols is cleared.
1. Bring up the VPRN service. BGP exchanges unicast routing information.
2. Bring up the IPv4 PIM protocol. BGP exchanges IPv4 multicast routing information in order to build PMSI infrastructure.
3. Bring up IGMP and add a static IGMP join where it is applicable. BGP exchanges IPv4 multicast routing information in order to propagate the multicast traffic to the receiver.
4. Bring up the IPv6 PIM protocol. BGP exchanges IPv6 multicast routing information in order to build the PMSI infrastructure.
5. Bring up MLD and add a static MLD join where it is applicable. BGP exchanges IPv6 multicast routing information in order to propagate the multicast traffic to the receiver.

The BGP debug output below is taken from PE-1 and demonstrates the message flow between PE-1 and PE-3.

Note: The PMSI part is present in debug messages 7584 and 7585, which are sent by PE-3 (**sender-only**).

Step 0: Bring down service and protocols to clear the state of all signaling protocols.

```
*A:PE-1>config>service>vprn# shutdown
*A:PE-1>config>service>vprn# pim shutdown
*A:PE-1>config>service>vprn# igmp shutdown
*A:PE-1>config>service>vprn# mld shutdown
*A:PE-1>config>service>vprn# pim ipv6-multicast-disable
```

Step 1. Enable the VPRN service on PE-1. PE-1 immediately receives Intra-AD messages from PE-3 because the remote VPRN service is already enabled for IPv4 and IPv6 multicast propagation. The PMSI attribute is present in both messages.

```
*A:PE-1>config>service>vprn# no shutdown
7584 2013/10/25 13:15:30.73 CEST MINOR: DEBUG #2001 Base Peer 1: 192.0.2.3
"Peer 1: 192.0.2.3: UPDATE
Peer 1: 192.0.2.3 - Received BGP UPDATE:
  Withdrawn Length = 0
  Total Path Attr Length = 91
  Flag: 0x90 Type: 14 Len: 23 Multiprotocol Reachable NLRI:
    Address Family MVPN_IPV4
    NextHop len 4 NextHop 192.0.2.3
    Type: Intra-AD Len: 12 RD: 64500:203 Orig: 192.0.2.3
  Flag: 0x40 Type: 1 Len: 1 Origin: 0
  Flag: 0x40 Type: 2 Len: 0 AS Path:
  Flag: 0x80 Type: 4 Len: 4 MED: 0
  Flag: 0x40 Type: 5 Len: 4 Local Preference: 100
  Flag: 0xc0 Type: 8 Len: 4 Community:
    no-export
  Flag: 0xc0 Type: 16 Len: 8 Extended Community:
    target:64500:2
  Flag: 0xc0 Type: 22 Len: 22 PMSI:
    Tunnel-type LDP P2MP LSP (2)
    Flags [Leaf not required]
    MPLS Label 0
    Root-Node 192.0.2.3, LSP-ID 0x2001
"

7585 2013/10/25 13:15:30.73 CEST MINOR: DEBUG #2001 Base Peer 1: 192.0.2.3
"Peer 1: 192.0.2.3: UPDATE
Peer 1: 192.0.2.3 - Received BGP UPDATE:
  Withdrawn Length = 0
  Total Path Attr Length = 91
  Flag: 0x90 Type: 14 Len: 23 Multiprotocol Reachable NLRI:
    Address Family MVPN_IPV6
    NextHop len 4 NextHop 192.0.2.3
    Type: Intra-AD Len: 12 RD: 64500:203 Orig: 192.0.2.3
  Flag: 0x40 Type: 1 Len: 1 Origin: 0
  Flag: 0x40 Type: 2 Len: 0 AS Path:
  Flag: 0x80 Type: 4 Len: 4 MED: 0
  Flag: 0x40 Type: 5 Len: 4 Local Preference: 100
  Flag: 0xc0 Type: 8 Len: 4 Community:
    no-export
  Flag: 0xc0 Type: 16 Len: 8 Extended Community:
    target:64500:2
  Flag: 0xc0 Type: 22 Len: 22 PMSI:
    Tunnel-type LDP P2MP LSP (2)
    Flags [Leaf not required]
    MPLS Label 0
    Root-Node 192.0.2.3, LSP-ID 0x2001
"
```

Step 2. Enable PIM IPv4 only for the service on PE-1. PE-1 immediately sends Intra-AD messages to PE-3.

```
*A:PE-1>config>service>vprn# pim no shutdown
*A:PE-1>config>service>vprn#

7586 2013/10/25 13:16:43.72 CEST MINOR: DEBUG #2001 Base Peer 1: 192.0.2.3
"Peer 1: 192.0.2.3: UPDATE
Peer 1: 192.0.2.3 - Send BGP UPDATE:
  Withdrawn Length = 0
  Total Path Attr Length = 91
  Flag: 0x90 Type: 14 Len: 23 Multiprotocol Reachable NLRI:
    Address Family MVPN_IPV4
    NextHop len 4 NextHop 192.0.2.1
    Type: Intra-AD Len: 12 RD: 64500:201 Orig: 192.0.2.1
  Flag: 0x40 Type: 1 Len: 1 Origin: 0
  Flag: 0x40 Type: 2 Len: 0 AS Path:
  Flag: 0x80 Type: 4 Len: 4 MED: 0
  Flag: 0x40 Type: 5 Len: 4 Local Preference: 100
  Flag: 0xc0 Type: 8 Len: 4 Community:
    no-export
  Flag: 0xc0 Type: 16 Len: 8 Extended Community:
    target:64500:2
  Flag: 0xc0 Type: 22 Len: 22 PMSI:
    Tunnel-type LDP P2MP LSP (2)
    Flags [Leaf not required]
    MPLS Label 0
    Root-Node 192.0.2.1, LSP-ID 0x2001
"
```

Step 3. Bring up IGMP and add a static IGMP join for the service on a PE-1. PE-1 immediately sends a source-join message to PE-3 and receives a source-AD message from PE-3.

```
*A:PE-1>config>service>vprn# igmp no shutdown
*A:PE-1>config>service>vprn# igmp interface "int-mcast-receiver" static group 232.0.0.1
source 172.16.3.1
```

```
7587 2013/10/25 13:17:19.68 CEST MINOR: DEBUG #2001 Base Peer 1: 192.0.2.3
"Peer 1: 192.0.2.3: UPDATE
Peer 1: 192.0.2.3 - Send BGP UPDATE:
  Withdrawn Length = 0
  Total Path Attr Length = 69
  Flag: 0x90 Type: 14 Len: 33 Multiprotocol Reachable NLRI:
    Address Family MVPN_IPV4
    NextHop len 4 NextHop 192.0.2.1
    Type: Source-Join Len:22 RD: 64500:203 SrcAS: 64500 Src: 172.16.3.1
  Grp: 232.0.0.1
  Flag: 0x40 Type: 1 Len: 1 Origin: 0
  Flag: 0x40 Type: 2 Len: 0 AS Path:
  Flag: 0x80 Type: 4 Len: 4 MED: 0
  Flag: 0x40 Type: 5 Len: 4 Local Preference: 100
  Flag: 0xc0 Type: 16 Len: 8 Extended Community:
    target:192.0.2.3:2087
"
```

```
7588 2013/10/25 13:17:20.43 CEST MINOR: DEBUG #2001 Base Peer 1: 192.0.2.3
"Peer 1: 192.0.2.3: UPDATE
Peer 1: 192.0.2.3 - Received BGP UPDATE:
  Withdrawn Length = 0
  Total Path Attr Length = 65
  Flag: 0x90 Type: 14 Len: 29 Multiprotocol Reachable NLRI:
    Address Family MVPN_IPV4
    NextHop len 4 NextHop 192.0.2.3
    Type: Source-AD Len: 18 RD: 64500:203 Src: 172.16.3.1 Grp: 232.0.0.1
  Flag: 0x40 Type: 1 Len: 1 Origin: 0
  Flag: 0x40 Type: 2 Len: 0 AS Path:
  Flag: 0x80 Type: 4 Len: 4 MED: 0
  Flag: 0x40 Type: 5 Len: 4 Local Preference: 100
  Flag: 0xc0 Type: 16 Len: 8 Extended Community:
    target:64500:2
"
```

Step 4. Enable PIM IPv6 for the service on PE-1. PE-1 immediately sends Intra-AD messages to PE-3.

```
*A:PE-1>config>service>vprn# pim no ipv6-multicast-disable
*A:PE-1>config>service>vprn#
```

```
7589 2013/10/25 13:18:42.72 CEST MINOR: DEBUG #2001 Base Peer 1: 192.0.2.3
"Peer 1: 192.0.2.3: UPDATE
Peer 1: 192.0.2.3 - Send BGP UPDATE:
  Withdrawn Length = 0
  Total Path Attr Length = 91
  Flag: 0x90 Type: 14 Len: 23 Multiprotocol Reachable NLRI:
    Address Family MVPN_IPV6
```

mLDP-Based MVPN Configuration

```
NextHop len 4 NextHop 192.0.2.1
Type: Intra-AD Len: 12 RD: 64500:201 Orig: 192.0.2.1
Flag: 0x40 Type: 1 Len: 1 Origin: 0
Flag: 0x40 Type: 2 Len: 0 AS Path:
Flag: 0x80 Type: 4 Len: 4 MED: 0
Flag: 0x40 Type: 5 Len: 4 Local Preference: 100
Flag: 0xc0 Type: 8 Len: 4 Community:
no-export
Flag: 0xc0 Type: 16 Len: 8 Extended Community:
target:64500:2
Flag: 0xc0 Type: 22 Len: 22 PMSI:
Tunnel-type LDP P2MP LSP (2)
Flags [Leaf not required]
MPLS Label 0
Root-Node 192.0.2.1, LSP-ID 0x2001
"
```

Step 5. Bring up MLD and add a static MLD join for the service on a PE-1. PE-1 immediately sends a source-join message to PE-3 and receives a source-AD message from PE-3.

```
*A:PE-1>config>service>vprn# mld no shutdown
*A:PE-1>config>service>vprn# mld interface "int-mcast-receiver" static group FF3E::8000:1
source 2001:DB8:3::1
```

```
7590 2013/10/25 13:18:57.68 CEST MINOR: DEBUG #2001 Base Peer 1: 192.0.2.3
"Peer 1: 192.0.2.3: UPDATE
Peer 1: 192.0.2.3 - Send BGP UPDATE:
Withdrawn Length = 0
Total Path Attr Length = 93
Flag: 0x90 Type: 14 Len: 57 Multiprotocol Reachable NLRI:
Address Family MVPN_IPV6
NextHop len 4 NextHop 192.0.2.1
Type: Source-Join Len: 46 RD: 64500:203 SrcAS: 64500 Src: 2001:DB8:3
::1 Grp: FF3E::8000:1
Flag: 0x40 Type: 1 Len: 1 Origin: 0
Flag: 0x40 Type: 2 Len: 0 AS Path:
Flag: 0x80 Type: 4 Len: 4 MED: 0
Flag: 0x40 Type: 5 Len: 4 Local Preference: 100
Flag: 0xc0 Type: 16 Len: 8 Extended Community:
target:192.0.2.3:2087
"
```

```
7591 2013/10/25 13:18:58.43 CEST MINOR: DEBUG #2001 Base Peer 1: 192.0.2.3
"Peer 1: 192.0.2.3: UPDATE
Peer 1: 192.0.2.3 - Received BGP UPDATE:
Withdrawn Length = 0
Total Path Attr Length = 89
Flag: 0x90 Type: 14 Len: 53 Multiprotocol Reachable NLRI:
Address Family MVPN_IPV6
NextHop len 4 NextHop 192.0.2.3
Type: Source-AD Len: 42 RD: 64500:203 Src: 2001:DB8:3::1 Grp: FF3E
::8000:1
Flag: 0x40 Type: 1 Len: 1 Origin: 0
Flag: 0x40 Type: 2 Len: 0 AS Path:
Flag: 0x80 Type: 4 Len: 4 MED: 0
Flag: 0x40 Type: 5 Len: 4 Local Preference: 100
Flag: 0xc0 Type: 16 Len: 8 Extended Community:
```

```
target:64500:2
"
```

The same information can be gathered using the following show commands.

show router bgp neighbor <peer> advertised-routes [mvpn-ipv4|mvpn-ipv6]

show router bgp neighbor <peer> received-routes [mvpn-ipv4|mvpn-ipv6]

PE-1 output for the advertised routes for the mvpn-ipv4 address family.

```
*A:PE-1# show router bgp neighbor 192.0.2.3 advertised-routes mvpn-ipv4
=====
BGP MVPN-IPv4 Routes
=====
Flag  RouteType          OriginatorIP      LocalPref  MED
      RD              SourceAS          Label
      Nexthop         SourceIP
      As-Path        GroupIP
-----
i     Intra-Ad          192.0.2.1        100        0
      64500:201        -                -
      192.0.2.1        -
      No As-Path      -
i     Source-Join      -                100        0
      64500:203        64500            -
      192.0.2.1        172.16.3.1
      No As-Path      232.0.0.1
-----
Routes : 2
=====
```

PE-1 output for the advertised routes for the mvpn-ipv6 address family.

```
*A:PE-1# show router bgp neighbor 192.0.2.3 advertised-routes mvpn-ipv6
=====
BGP MVPN-IPv6 Routes
=====
Flag  RouteType          OriginatorIP      LocalPref  MED
      RD              SourceAS          Label
      Nexthop         SourceIP
      As-Path        GroupIP
-----
i     Intra-Ad          192.0.2.1        100        0
      64500:201        -                -
      192.0.2.1        -
      No As-Path      -
i     Source-Join      -                100        0
      64500:203        64500            -
      192.0.2.1        2001:DB8:3::1
      No As-Path      FF3E::8000:1
-----
Routes : 2
=====
```

mLDP-Based MVPN Configuration

PE-1 output for the received routes for the mvpn-ipv4 address family.

```
A:PE-1# show router bgp neighbor 192.0.2.3 received-routes mvpn-ipv4
=====
BGP MVPN-IPv4 Routes
=====
Flag  RouteType          OriginatorIP      LocalPref  MED
      RD              SourceAS          Label
      Nexthop         SourceIP
      As-Path        GroupIP
-----
u*>i  Intra-Ad           192.0.2.3        100        0
      64500:203      -                -
      192.0.2.3      -
      No As-Path     -
u*>i  Source-Ad          -                100        0
      64500:203      -                -
      192.0.2.3      172.16.3.1
      No As-Path     232.0.0.1
-----
Routes : 2
=====
```

PE-1 output for the received routes for the mvpn-ipv6 address family.

```
A:PE-1# show router bgp neighbor 192.0.2.3 received-routes mvpn-ipv6
=====
BGP MVPN-IPv6 Routes
=====
Flag  RouteType          OriginatorIP      LocalPref  MED
      RD              SourceAS          Label
      Nexthop         SourceIP
      As-Path        GroupIP
-----
u*>i  Intra-Ad           192.0.2.3        100        0
      64500:203      -                -
      192.0.2.3      -
      No As-Path     -
u*>i  Source-Ad          -                100        0
      64500:203      -                -
      192.0.2.3      2001:DB8:3::1
      No As-Path     FF3E::8000:1
-----
Routes : 2
=====
```

LDP Verification and Debugging

When BGP intra-AD messages are exchanged every PE starts to build a multicast tunnel based on the following criteria:

PE nodes which are configured as **sender-only** do not distribute mLDP Forward Equivalence Classes (FECs) to remote PEs for this MVPN.

PE nodes which configured as receiver-only do not include the PMSI part for intra-AD messages and remote PEs do not send mLDP FECs for this MVPN.

LDP bindings can be verified using the following command:

show router ldp bindings fec-type p2mp

PE-1 (192.0.2.1) has one ingress FEC and one egress FEC due to the fact that PE-1 has the default **mdt-type sender-receiver**.

```
*A:PE-1# show router ldp bindings fec-type p2mp
=====
LDP LSR ID: 192.0.2.1
=====
Legend: U - Label In Use, N - Label Not In Use, W - Label Withdrawn
       WP - Label Withdraw Pending, BU - Alternate For Fast Re-Route
=====
LDP Generic P2MP Bindings
=====
P2MP-Id      RootAddr
Interface    Peer          IngLbl      EgrLbl  EgrIntf/    EgrNextHop
                               EgrIntf/    LspId
                               LspId
-----
8193         192.0.2.1
73734        192.0.2.2      --          256033  3/1/1       192.168.12.1

8193         192.0.2.3
73735        192.0.2.3      261935U    --      --          --

-----
No. of Generic P2MP Bindings: 2
```

PE-2 (192.0.2.2) has two ingress FECs due to the fact that PE-2 has **mdt-type receiver-only**.

```
A:PE-2# show router ldp bindings fec-type p2mp
=====
LDP LSR ID: 192.0.2.2
=====
Legend: U - Label In Use, N - Label Not In Use, W - Label Withdrawn
       WP - Label Withdraw Pending, BU - Alternate For Fast Re-Route
=====
LDP Generic P2MP Bindings
=====
P2MP-Id      RootAddr
Interface    Peer          IngLbl      EgrLbl  EgrIntf/    EgrNextHop
                               EgrIntf/    LspId
                               LspId
-----
```

mLDP-Based MVPN Configuration

```

-----
LspId
-----
8193          192.0.2.1
73733        192.0.2.1      256033U    --    --    --

8193          192.0.2.3
73732        192.0.2.3      256034U    --    --    --

-----
No. of Generic P2MP Bindings: 2

```

PE-3 (192.0.2.3) has two egress FECs due to the fact that PE-3 has **mdt-type sender-only**.

```

*A:PE-3# show router ldp bindings fec-type p2mp
=====
LDP LSR ID: 192.0.2.3
=====
Legend: U - Label In Use, N - Label Not In Use, W - Label Withdrawn
        WP - Label Withdraw Pending, BU - Alternate For Fast Re-Route
=====
LDP Generic P2MP Bindings
=====
P2MP-Id      RootAddr
Interface    Peer          IngLbl    EgrLbl  EgrIntf/    EgrNextHop
                               LspId
-----
8193          192.0.2.3
73752        192.0.2.1      --        261935  3/1/4        192.168.13.0

8193          192.0.2.3
73752        192.0.2.2      --        256034  1/1/1        192.168.23.0

-----
No. of Generic P2MP Bindings: 2

```

Multicast Stream Verification

Status of multicast group/stream can be verified using the following command

show router <sid> pim group detail [ipv6]

There is IPv4 receiver connected to PE-1. I-PMSI is used as incoming interface and physical interface where receiver is connected is used as outgoing.

```
A:PE-1# show router 2 pim group detail
=====
PIM Source Group ipv4
=====
Group Address      : 232.0.0.1
Source Address     : 172.16.3.1
RP Address         : 0
Advt Router        : 192.0.2.3
Flags              :                               Type           : (S,G)
MRIB Next Hop     : 192.0.2.3
<snip>
Rpf Neighbor       : 192.0.2.3
Incoming Intf     : mpls-if-73735
Outgoing Intf List : int-mcast-receiver

Curr Fwding Rate   : 85614.0 kbps
<snip>
```

There is IPv4 receiver connected to PE-2. I-PMSI is used as incoming interface and physical interface where receiver is connected is used as outgoing.

```
A:PE-2# show router 2 pim group detail
=====
PIM Source Group ipv4
=====
Group Address      : 232.0.0.1
Source Address     : 172.16.3.1
RP Address         : 0
Advt Router        : 192.0.2.3
Flags              :                               Type           : (S,G)
MRIB Next Hop     : 192.0.2.3
<snip>
Rpf Neighbor       : 192.0.2.3
Incoming Intf     : mpls-if-73732
Outgoing Intf List : int-mcast-receiver

Curr Fwding Rate   : 85615.1 kbps
<snip>
```

There is IPv4 sender connected to PE-3. I-PMSI is used as outgoing interface and physical interface where sender is connected is used as incoming.

```
*A:PE-3# show router 2 pim group detail
=====
PIM Source Group ipv4
=====
Group Address      : 232.0.0.1
Source Address     : 172.16.3.1
RP Address         : 0
Advt Router       : 192.0.2.3
Flags              :                               Type           : (S,G)
MRIB Next Hop     : 172.16.3.1
<snip>
Rpf Neighbor      : 172.16.3.1
Incoming Intf     : int-mcast-source
Outgoing Intf List : mpls-if-73752

Curr Fwding Rate  : 85638.1 kbps
<snip>
```

Similar behavior is observed for IPv6 multicast.

There is an IPv6 receiver connected to PE-1. An I-PMSI is used as the incoming interface and the physical interface where the receiver is connected is used as the outgoing interface.

```
A:PE-1# show router 2 pim group detail ipv6
=====
PIM Source Group ipv6
=====
Group Address      : FF3E::8000:1
Source Address     : 2001:DB8:3::1
RP Address         : 0
Advt Router       : 192.0.2.3
Flags              :                               Type           : (S,G)
MRIB Next Hop     : 192.0.2.3
<snip>
Rpf Neighbor      : 192.0.2.3
Incoming Intf     : mpls-if-73735
Outgoing Intf List : int-mcast-receiver

Curr Fwding Rate  : 2140.5 kbps
<snip>
```

There is an IPv6 receiver connected to PE-2. An I-PMSI is used as the incoming interface and the physical interface where the receiver is connected is used as the outgoing interface.

```
A:PE-2# show router 2 pim group detail ipv6
=====
PIM Source Group ipv6
=====
Group Address      : FF3E::8000:1
Source Address     : 2001:DB8:3::1
```

Multicast VPN: Sender-Only, Receiver-Only

```
RP Address      : 0
Advt Router    : 192.0.2.3
Flags          :                               Type           : (S,G)
MRIB Next Hop  : 192.0.2.3
<snip>
Rpf Neighbor   : 192.0.2.3
Incoming Intf  : mpls-if-73732
Outgoing Intf List : int-mcast-receiver

Curr Fwding Rate : 2140.5 kbps
<snip>
```

There is an IPv6 sender connected to PE-3. An I-PMSI is used as the outgoing interface and the physical interface where the sender is connected is used as the incoming interface.

```
*A:PE-3# show router 2 pim group detail ipv6
=====
PIM Source Group ipv6
=====
Group Address   : FF3E::8000:1
Source Address  : 2001:DB8:3::1
RP Address      : 0
Advt Router    : 192.0.2.3
Flags          :                               Type           : (S,G)
MRIB Next Hop  : 2001:DB8:3::1
<snip>
Rpf Neighbor   : 2001:DB8:3::1
Incoming Intf  : int-mcast-source
Outgoing Intf List : mpls-if-73752

Curr Fwding Rate : 2140.5 kbps
<snip>
```

Conclusion

The sender-only/receiver-only feature provides significant signaling optimization in the core network for RSVP and LDP protocols and is recommended to be used when such functionality is required. The following are required before implementing this feature in the network:

- MDT-types **sender-only**, **receiver-only** and **sender-receiver** are enabled per MVPN.
- The default mdt-type is **sender-receiver** mode for backward compatibility.
- This is purely a control plane feature and there are no hardware dependencies, except for requiring chassis mode C or later.
- Draft Rosen or MDT-SAFI based MVPNs are not supported.
- IPv4 and IPv6 C-signaling are supported.
- mLDP and RSVP demonstrate slightly different behavior due to the nature of each protocol.
- mLDP provides a better optimization than RSVP in all cases, as mLDP does not initiate LSPs to sender-only routers.